



General Certificate of Secondary Education

Mathematics 9307

Pilot Specification
2009

SPECIMEN ASSESSMENT MATERIALS

Further copies of this booklet are available from:

The GCSE Mathematics Department, AQA, Devas Street, Manchester, M15 6EX
Telephone: 0161 957 3852 Fax: 0161 957 3873

Copyright © 2008 AQA and its licensors. All rights reserved.

COPYRIGHT

AQA retains the copyright on all its publications. However, registered centres for AQA are permitted to copy material from this booklet for their own internal use, with the following important exception: AQA cannot give permission to centres to photocopy any material that is acknowledged to a third party even for internal use within the centre.

Set and published by the Assessment and Qualifications Alliance.

Contents

Background Information

Introduction	5
Glossary for Mark Schemes	6

Unit 2 Statistics and number

Foundation Tier Specimen Paper – Section A	7
Foundation Tier Specimen Paper – Section B	15
Foundation Tier Mark Scheme – Sections A and B	21
Higher Tier Specimen Paper – Section A	29
Higher Tier Specimen Paper – Section B	37
Higher Tier Mark Scheme – Sections A and B	45

Unit 3 Geometry, measures and algebra Paper 1

Foundation Tier Specimen	53
Foundation Tier Mark Scheme	65
Higher Tier Specimen Paper	71
Higher Tier Mark Scheme	83

Unit 3 Geometry, measures and algebra Paper 2

Foundation Tier Specimen Paper	89
Foundation Tier Mark Scheme	105
Higher Tier Specimen Paper	111
Higher Tier Mark Scheme	125

Introduction

AQA have prepared a pilot specification for GCSE Mathematics as part of the Curriculum Pathways Project. The specimen assessment material accompanying the specifications is provided to give centres a reasonable idea of the general shape and character of the planned question papers in advance of the first operational examination.

Papers

These specimen question papers have been designed to exemplify the question papers, to be set for the Mathematics Specification, for examinations in January and June 2009. The associated mark scheme follows each paper.

The question papers are targeted at two tiers A* - D (Higher) and grades C - G (Foundation).

It should be noted that on both tiers candidates must not use a calculator for Section B of Unit 2 and Paper 1 of Unit 3.

The question papers should be read in conjunction with AQA Mathematics Specification 9307 for 2009.

The question papers are intended to represent the length and balance of the papers that will be set for the examination in 2009 and to indicate the types of questions that will be used. It must be emphasised, however, that the questions have not been subjected to the rigorous review that would take place with questions before use in examination.

Mark Schemes

Principal Examiners have prepared these mark schemes for specimen papers. These mark schemes have not, therefore, been through the normal process of standardising that would take place for live papers.

Glossary for Mark Schemes

GCSE examinations are marked in such a way as to award positive achievement wherever possible. Thus, for GCSE Mathematics papers, marks are awarded under various categories.

- M** Method marks are awarded for a correct method which could lead to a correct answer.
- A** Accuracy marks are awarded when following on from a correct method. It is not necessary to always see the method. This can be implied.
- B** Marks awarded independent of method.
- M dep** A method mark dependent on a previous method mark being awarded.
- B dep** A mark that can only be awarded if a previous independent mark has been awarded.
- ft** Follow through marks. Marks awarded following a mistake in an earlier step.
- SC** Special case. Marks awarded within the scheme for a common misinterpretation which has some mathematical worth.
- oe** Or equivalent. Accept answers that are equivalent.
eg, accept 0.5 as well as $\frac{1}{2}$

Surname					Other Names				
Centre Number					Candidate Number				
Candidate Signature									

For Examiner's Use

General Certificate of Secondary Education

MATHEMATICS (PILOT)
Unit 2 Foundation Tier Section A

93002/FA

F



Specimen Paper (Curriculum Pathways Pilot) 2009

<p>For this paper you must have:</p> <ul style="list-style-type: none"> • a calculator • mathematical instruments • a treasury tag. 	
---	--

Time allowed For Section A: 30 minutes

Instructions

- Use black ink or black ball-point pen. Draw diagrams in pencil.
- Fill in the boxes at the top of this page.
- Answer **all** questions.
- You must answer questions in the spaces provided. Answers written in margins will not be marked.
- Use a calculator where appropriate.
- Do all rough work in this book.
- This paper is divided into two sections: Section A and Section B.
- After the 30 minutes allowed for section A, you must put your calculator on the floor under your seat. You will then be given Section B.
- When you have answered Section B you may work again on Section A but you may **not** use your calculator. It must remain on the floor under your seat.
- At the end of the examination tag Section A and Section B together with Section A on top.

Information

- The maximum mark for Section A is 25.
- The marks for questions are shown in brackets.
- You may ask for more answer paper and graph paper. These must be tagged securely to this answer book.

Advice

- In all calculations, show clearly how you work out your answer.

For Examiner's Use			
Section A		Section B	
Question	Mark	Question	Mark
1		6	
2		7	
3		8	
4		9	
5		10	
Total Section A			
Total Section B			
TOTAL			
Examiner's Initials			

There are no questions printed on this page

**DO NOT WRITE ON THIS PAGE
ANSWER IN THE SPACES PROVIDED**

Answer **all** questions in the spaces provided.

- 1 (a) Shade 50% of the grid.

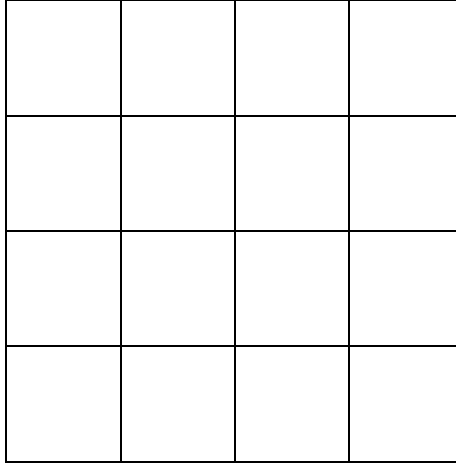

(1 mark)

- 1 (b) Work out $\frac{1}{4}$ of 360.

.....

Answer (1 mark)

- 1 (c) Write three-quarters as a decimal.

Answer (1 mark)

- 2 Calculate $\frac{4.386}{0.552}$

- 2 (a) Write down your full calculator display.

Answer (1 mark)

- 2 (b) Write your answer to two decimal places.

Answer (1 mark)

3

2

3 (a) Work out the median of:

-3 2 -6 1

.....

.....

.....

Answer (2 marks)

3 (b) A set of **six** cards is shown.

-3	2	-6	1		
----	---	----	---	--	--

Fill in the **two** blank cards so that
half of the six numbers are negative
and
the mode of the six numbers is negative.

.....

.....

.....

(2 marks)

3 (c) Here are some statements about the median of any set of numbers.
Only one statement is correct.

Tick the box of the correct statement.

- The median could be larger than the largest number.
- The median could be equal to the mode.
- The median must be one of the numbers in the set.

(1 mark)

4 Linda is looking at an advert on a wall.

Superspend
*Shop Assistants
Wanted*

Linda works at Shopsave.

She wonders if she would earn more working at Superspend.

Here is some information about Shopsave and Superspend.

Shopsave

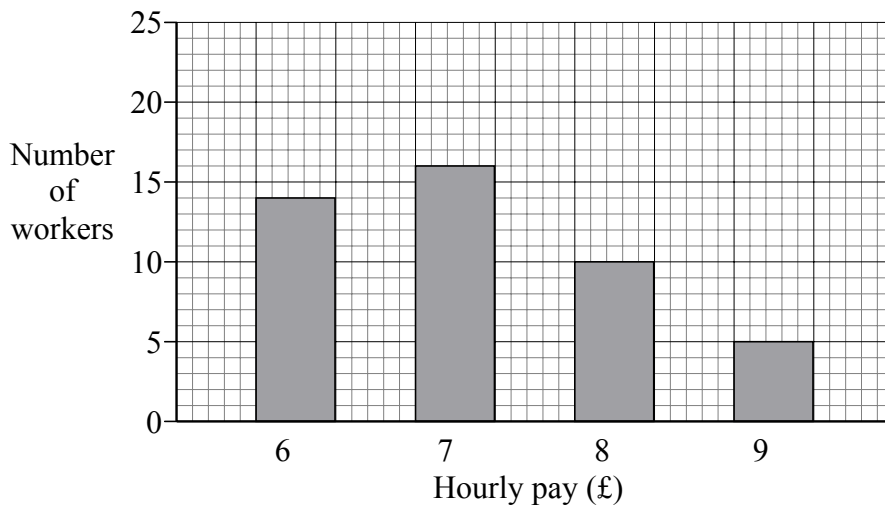

Superspend

Hourly Pay (£)	Number of workers
6	18
7	10
8	6
9	4
10	2

4 (a) For the workers at Shopsave

4 (a) (i) How many workers are paid £ 6 per hour?

Answer (1 mark)

4 (a) (ii) What fraction of workers are paid £ 9 per hour?

.....

Answer (2 marks)

4 (a) (iii) What is the range of their hourly pay?

.....

Answer £ (1 mark)

- 4 (b) The mean hourly pay at Shopsave is £ 7.13

Show the mean hourly pay at Superspend is £ 7.05

.....

.....

.....

.....

.....

(3 marks)

- 4 (c) Complete the dual bar chart to show the data for Shopsave and Superspend on the same graph.

The first pair of bars has been drawn for you.

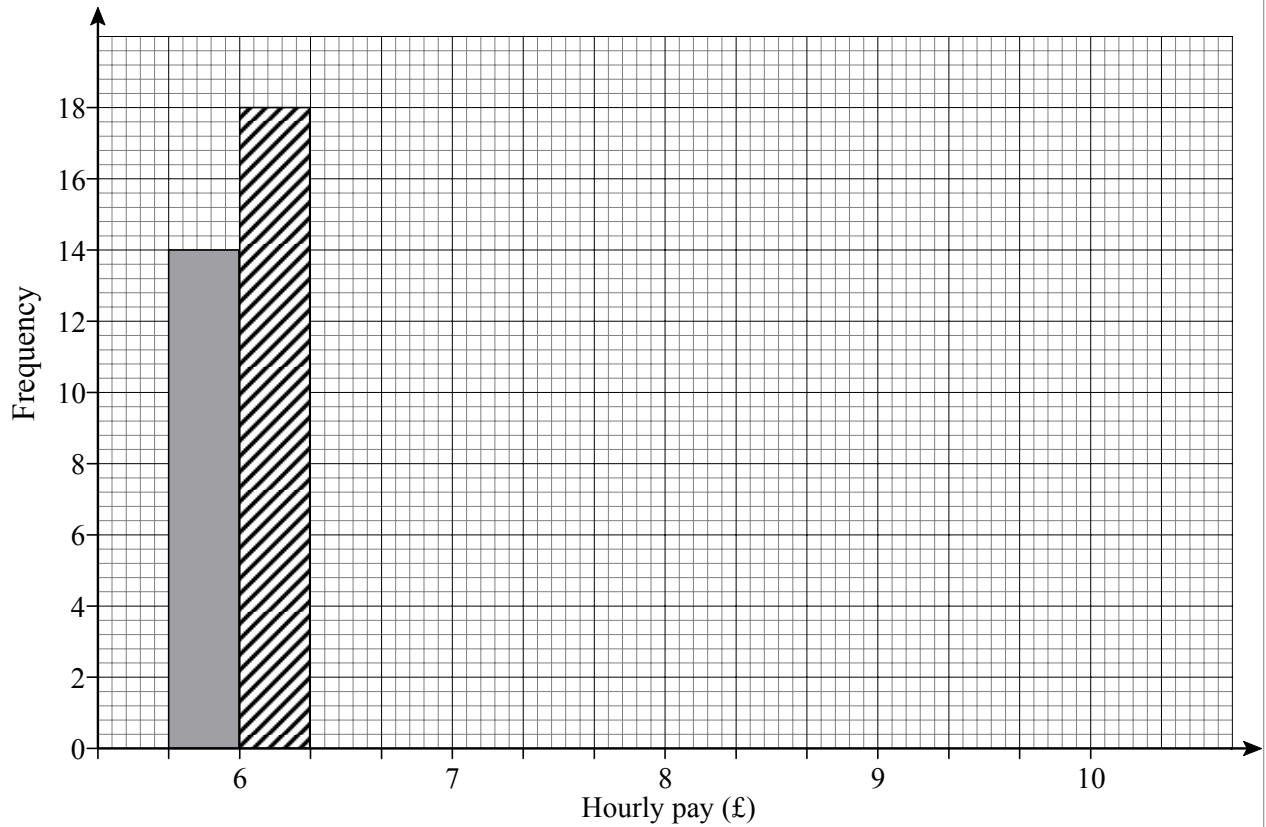

(3 marks)

4 (d) Compare the hourly pay at the two shops.

4 (d) (i) Give **one** reason why Linda should apply for a job at Superspend.

.....
.....

(1 mark)

4 (d) (ii) Give **one** reason why Linda should stay at Shopsave.

.....
.....

(1 mark)

5 The table shows the cost of photo frames on a website.

Photo frames £ 5.25 each	Postage and packing	
	Orders under £ 100	£ 10.50
	Orders £ 100 and over	FREE

Nikki spent a total of £ 110.25 on an order with this website.

How many photo frames could Nikki have bought?

Give the **two** possible answers.

.....
.....
.....

Answer or (3 marks)

12

3

END OF SECTION A

Surname					Other Names				
Centre Number					Candidate Number				
Candidate Signature									

For Examiner's Use

General Certificate of Secondary Education

MATHEMATICS (PILOT)
Unit 2 Foundation Tier Section B

93002/FB

F



Specimen Paper (Curriculum Pathways Pilot) 2009

<p>For this paper you must have:</p> <ul style="list-style-type: none"> mathematical instruments <p>You must not use a calculator.</p>	
---	--

Time allowed For Section B: 30 minutes

Instructions

- Use black ink or black ball-point pen. Draw diagrams in pencil.
- Fill in the boxes at the top of this page.
- Answer **all** questions.
- You must answer questions in the spaces provided. Answers written in margins will not be marked.
- Do all rough work in this book.
- You may not use your calculator in Section B. Your calculator must remain on the floor under your seat.
- When you have answered Section B you may work again on Section A but you may **not** use your calculator. It must remain on the floor under your seat.
- At the end of the examination tag Section A and Section B together with Section A on top.

Information

- The maximum mark for Section B is 25.
- The marks for questions are shown in brackets.
- You may ask for more answer paper and graph paper. These must be tagged securely to this answer book.

Advice

- In all calculations, show clearly how you work out your answer.

There are no questions printed on this page

**DO NOT WRITE ON THIS PAGE
ANSWER IN THE SPACES PROVIDED**

Answer **all** questions in the spaces provided.

6 (a) Put these words in order of likelihood.

Certain Impossible Unlikely Likely

Answer

(1 mark)

6 (b) Here is a probability scale.

Arrows A, B, C, D and E represent the probability of some outcomes when an ordinary fair dice is rolled **once**.

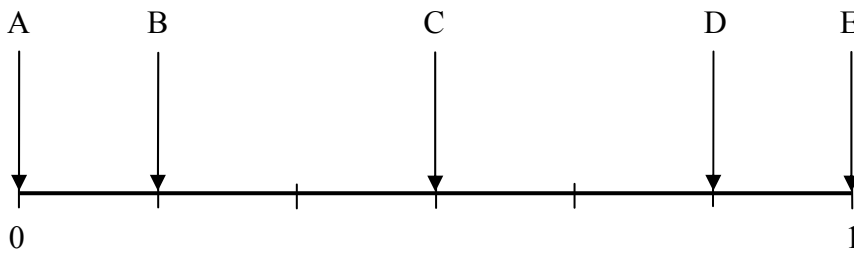

6 (b) (i) Which arrow represents the probability of rolling a 6?

Answer (1 mark)

6 (b) (ii) Which arrow represents the probability of rolling more than a 6?

Answer (1 mark)

6 (b) (iii) Describe an outcome that has the probability represented by arrow C.

.....

(1 mark)

4

- 7 (a) Abby catches the bus to the local shopping centre.
The bus fare is 75 p.
She pays the fare using three coins and receives 5 p change.

What three coins did she pay with?

.....

(1 mark)

- 7 (b) At the centre Abby goes into a shop.
She buys four pens at 30 p each and nothing else.
At the till Abby is charged £ 1.35 for the four pens.

- 7 (b) (i) Abby knows that this is the wrong total.

Explain how she knows this is wrong without working out the correct total.

.....
.....

(1 mark)

- 7 (b) (ii) Work out the correct total.
Give your answer in pounds.

.....

Answer £ (1 mark)

- 7 (c) Abby now goes into a shoe shop.
A pair of shoes originally costing £ 35 is for sale at half price.
Abby has £ 18.05 left in her purse.
She needs 75 p for the bus fare home.

Does she have enough money in her purse to buy the shoes and pay the bus fare?
You **must** explain your answer.

.....
.....
.....
.....
.....

(4 marks)

7

- 8 (a) Work out the mean of 6, 8, 10 and 12.

.....

Answer (1 mark)

- 8 (b) Work out 80% of 300.

.....

.....

Answer (2 marks)

- 8 (c) Work out $\frac{7}{10} + \frac{1}{4}$

.....

.....

.....

Answer (2 marks)

- 9 The table shows the number of each colour of ball used in a game of snooker.
These balls are stored in a box.

Colour	Red	Yellow	Green	Brown	Blue	Pink	Black	White
Number	15	1	1	1	1	1	1	1

- 9 (a) One ball is chosen at random from the box containing these balls.

What is the probability that it is either a pink or black ball?

Give your answer as a fraction in its simplest form.

.....

Answer (2 marks)

- 9 (b) In an experiment a ball is chosen at random from the box.
The colour is noted and the ball is then replaced in the box.
This experiment is repeated 110 times.

How many times would you expect a red ball to be chosen?

.....

.....

Answer (2 marks)

Turn over ►

5

4

10 87% of members of a bingo club are female.

10 (a) What percentage of members are male?

.....

Answer % (1 mark)

10 (b) The manager sends a free ticket to every fourth name on the club membership list.
He sends 155 free tickets altogether.

How many members does the club have?

.....

.....

Answer (2 marks)

10 (c) The manager is thinking about closing the club on Mondays.
He gives a questionnaire about this to the first 10 males and the first 10 females
to enter the club on Friday.

Is this a good sample to choose?

Yes No

Give **two** reasons for your decision.

Reason 1

.....

Reason 2

.....

(2 marks)

5

END OF QUESTIONS

General Certificate of Secondary Education

Mathematics (Pilot) 9307

Unit 2, Foundation Tier, Sections A and B

Mark Scheme

Specimen Paper

Mark schemes are prepared by the Principal Examiner and considered, together with the relevant questions, by a panel of subject teachers. This mark scheme includes any amendments made at the standardisation meeting attended by all examiners and is the scheme which was used by them in this examination. The standardisation meeting ensures that the mark scheme covers the candidates' responses to questions and that every examiner understands and applies it in the same correct way. As preparation for the standardisation meeting each examiner analyses a number of candidates' scripts: alternative answers not already covered by the mark scheme are discussed at the meeting and legislated for. If, after this meeting, examiners encounter unusual answers which have not been discussed at the meeting they are required to refer these to the Principal Examiner.

It must be stressed that a mark scheme is a working document, in many cases further developed and expanded on the basis of candidates' reactions to a particular paper. Assumptions about future mark schemes on the basis of one year's document should be avoided; whilst the guiding principles of assessment remain constant, details will change, depending on the content of a particular examination paper.

Further copies of this Mark Scheme are available to download from the AQA Website: www.aqa.org.uk

Copyright © 2008 AQA and its licensors. All rights reserved.

The Assessment and Qualifications Alliance (AQA) is a company limited by guarantee registered in England and Wales 3644723 and registered charity number 1073334.
Registered address AQA, Devas Street, Manchester M15 6EX *Dr Michael Cresswell Director General.*

Glossary for Mark Schemes

GCSE examinations are marked in such a way as to award positive achievement wherever possible. Thus, for GCSE Mathematics papers, marks are awarded under various categories.

- M** Method marks are awarded for a correct method which could lead to a correct answer.
- A** Accuracy marks are awarded when following on from a correct method. It is not necessary to always see the method. This can be implied.
- B** Marks awarded independent of method.
- D** Marks awarded independent of method for correct use of data sheet.
- M dep** A method mark dependent on a previous method mark being awarded.
- B dep** A mark that can only be awarded if a previous independent mark has been awarded.
- ft** Follow through marks. Marks awarded following a mistake in an earlier step.
- SC** Special case. Marks awarded within the scheme for a common misinterpretation which has some mathematical worth.
- oe** Or equivalent. Accept answers that are equivalent.
eg, accept 0.5 as well as $\frac{1}{2}$

Section A

Q	Answer	Mark	Comments
1(a)	Exactly 8 squares shaded	B1	
1(b)	90	B1	
1(c)	(0).75	B1	
2(a)	7.9456522...	B1	
2(b)	7.95	B1ft	
3(a)	Orders data	M1	or Sight of attempt to find mean of -3 and 1
	-1		
3(b)	-6 and a positive number other than 1 or 2 OR -3 and a positive number other than 1 or 2	B2	B1 Only one of the two conditions are met
3(c)	Second box ticked	B1	

Q	Answer	Mark	Comments																					
4(a)(i)	14	B1																						
4(a)(ii)	$\frac{5}{45}$	B2	B1 Numerator B1 Denominator oe																					
4(a)(iii)	3	B1	Condone 6 – 9 due to context																					
4(b)	One correct example of ' fx '	M1	<table border="1"> <thead> <tr> <th>Hourly wage (£)</th> <th>Frequency</th> <th>fx</th> </tr> </thead> <tbody> <tr> <td>6</td> <td>18</td> <td>108</td> </tr> <tr> <td>7</td> <td>10</td> <td>70</td> </tr> <tr> <td>8</td> <td>6</td> <td>48</td> </tr> <tr> <td>9</td> <td>4</td> <td>36</td> </tr> <tr> <td>10</td> <td>2</td> <td>20</td> </tr> <tr> <td colspan="2"></td> <td>$\Sigma = 282$</td> </tr> </tbody> </table>	Hourly wage (£)	Frequency	fx	6	18	108	7	10	70	8	6	48	9	4	36	10	2	20			$\Sigma = 282$
	Hourly wage (£)	Frequency		fx																				
	6	18		108																				
7	10	70																						
8	6	48																						
9	4	36																						
10	2	20																						
		$\Sigma = 282$																						
At least 4 fx correct and an attempt to total	M1dep																							
Total divided by 40	A1																							
4(c)	Pairs of bars to correct heights	B2	-1 each error																					
	Structure correct ie, pairs together but gaps between pairs	B1																						
4(d)(i)	Some earn £ 10 at Superspend or higher relative frequency of £ 9	B1	oe																					
4(d)(ii)	Mean higher at Shopsave or fewer earn £ 6	B1	oe Could also refer to mode																					

5	$\frac{110.25}{5.25} = 21$	B1	
	$\frac{110.25 - 10.50}{5.25}$	M1	
	19	A1	

Q	Answer	Mark	Comments
---	--------	------	----------

Section B

6(a)	Impossible, Unlikely, Likely, Certain	B1	
6(b)(i)	B	B1	
6(b)(ii)	A	B1	
6(b)(iii)	Any dice outcome having probability of $\frac{1}{2}$	B1	

7(a)	50p, 20p, 10p	B1	
7(b)(i)	The amount must end in a zero	B1	oe
7(b)(ii)	£1.20	B1	
7(c)	$35 \div 2$	M1	oe
	17.50	A1	
	$18.05 - 0.75$	M1	17.30
	No, not enough	A1ft	Must see evidence for M2 to award 4 marks ft their 17.50 and their 17.30

8(a)	9	B1	
8(b)	0.8×300	M1	oe Build up must be completely correct in method
	240	A1	
8(c)	Appropriate common denominator with at least one correct numerator	M1	eg, $\frac{14}{20} + \frac{5}{20}$
	$\frac{19}{20}$	A1	oe eg, $\frac{38}{40}$ or 0.95

9(a)	$\frac{1}{11}$	B2	B1 $\frac{2}{22}$
9(b)	$\frac{15}{22} \times 110$	M1	15×5
	75	A1	

Q	Answer	Mark	Comments
10(a)	13	B1	
10(b)	155×4	M1	
	620	A1	
10(c)	No ticked with any two B1 answers given	B2	<p>B1 Friday customers might not care about Monday</p> <p>B1 Most of the members are women but half of questionnaires to men</p> <p>B1 First people to arrive are not typical of all members</p> <p>B1 Should ask people who are not currently visiting the club</p> <p>B1 Other sensible answer</p>

Surname					Other Names				
Centre Number					Candidate Number				
Candidate Signature									

For Examiner's Use

General Certificate of Secondary Education

MATHEMATICS (PILOT)
Unit 2 Higher Tier Section A

93002/HA

H



Specimen Paper (Curriculum Pathways Pilot) 2009

<p>For this paper you must have:</p> <ul style="list-style-type: none"> • a calculator • mathematical instruments • a treasury tag. 	
---	--

Time allowed For Section A: 30 minutes

Instructions

- Use black ink or black ball-point pen. Draw diagrams in pencil.
- Fill in the boxes at the top of this page.
- Answer **all** questions.
- You must answer questions in the spaces provided. Answers written in margins will not be marked.
- Use a calculator where appropriate.
- Do all rough work in this book.
- This paper is divided into two sections: Section A and Section B.
- After the 30 minutes allowed for section A, you must put your calculator on the floor under your seat. You will then be given Section B.
- When you have answered Section B you may work again on Section A but you may **not** use your calculator. It must remain on the floor under your seat.
- At the end of the examination tag Section A and Section B together with Section A on top.

Information

- The maximum mark for Section A is 25.
- The marks for questions are shown in brackets.
- You may ask for more answer paper and graph paper. These must be tagged securely to this answer book.

Advice

- In all calculations, show clearly how you work out your answer.

For Examiner's Use			
Section A		Section B	
Question	Mark	Question	Mark
1		5	
2		6	
3		7	
4		8	
		9	
Total Section A			
Total Section B			
TOTAL			
Examiner's Initials			

There are no questions printed on this page

**DO NOT WRITE ON THIS PAGE
ANSWER IN THE SPACES PROVIDED**

Answer **all** questions in the spaces provided.

- 1** The table shows the cost of photo frames on a website.

Photo frames £ 5.25 each	Postage and packing	
	Orders under £ 100	£ 10.50
	Orders £ 100 and over	FREE

Nikki spent a total of £ 110.25 on an order with this website.

How many photo frames could Nikki have bought?

Give the **two** possible answers.

.....

.....

.....

Answer or (3 marks)

3

Turn over for the next question

- 2 Linda is looking at an advert on a wall.



Linda works at Shopsave.

She wonders if she could earn more working at Superspend.

Here is some information about hourly pay at Shopsave and Superspend.

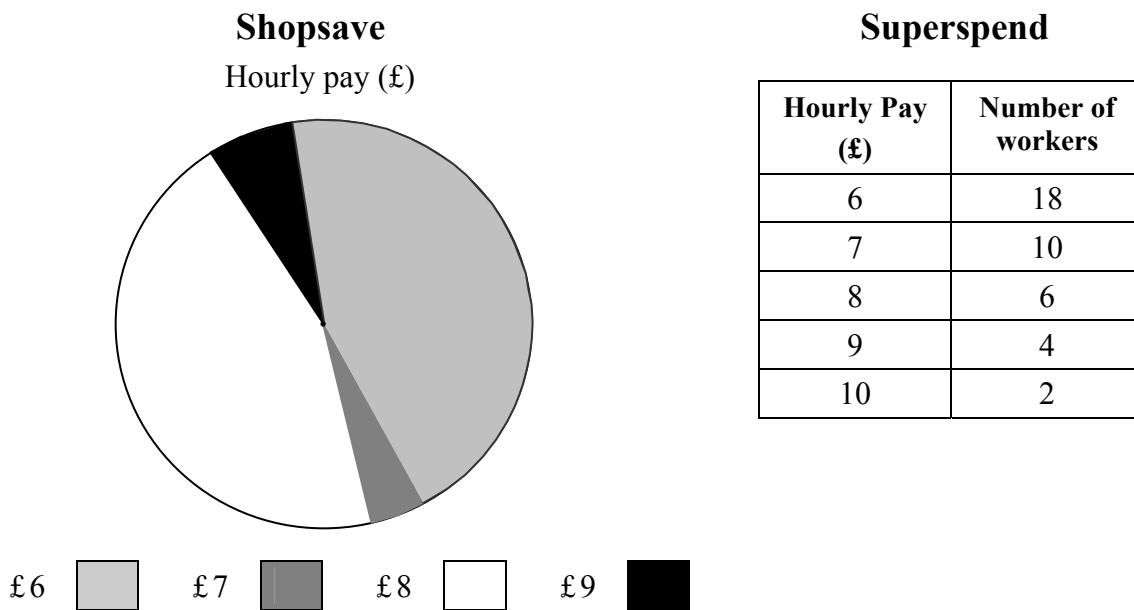

- 2 (a) Work out the relative frequency of the hourly pay of £9 at Superspend.

.....

Answer (1 mark)

- 2 (b) At Shopsave the relative frequency of the hourly pay of £9 is $\frac{3}{45}$.

Tick the correct statements.

- The number of workers in Shopsave is 45.
- The number of workers in Shopsave is a multiple of 45.
- $\frac{42}{45}$ is the relative frequency of hourly pay less than £9.
- Less than 10% of workers have hourly pay of £9.

(2 marks)

2 (c) At Shopsave, the median hourly pay is £8.
Also at Shopsave, the mean hourly pay is £7.13

2 (c) (i) Compare the hourly rates of pay for Shopsave and Superspend.

.....
.....
.....
.....
.....
.....
.....

(5 marks)

2 (c) (ii) Give **one** reason why Linda should apply for a job at Superspend.

.....
.....

(1 mark)

2 (c) (ii) Give **one** reason why Linda should stay at Shopsave.

.....
.....

(1 mark)

10

3 Shabir is comparing the ages of workers in a bank and an office.

The histogram shows the age distribution of workers in a bank.

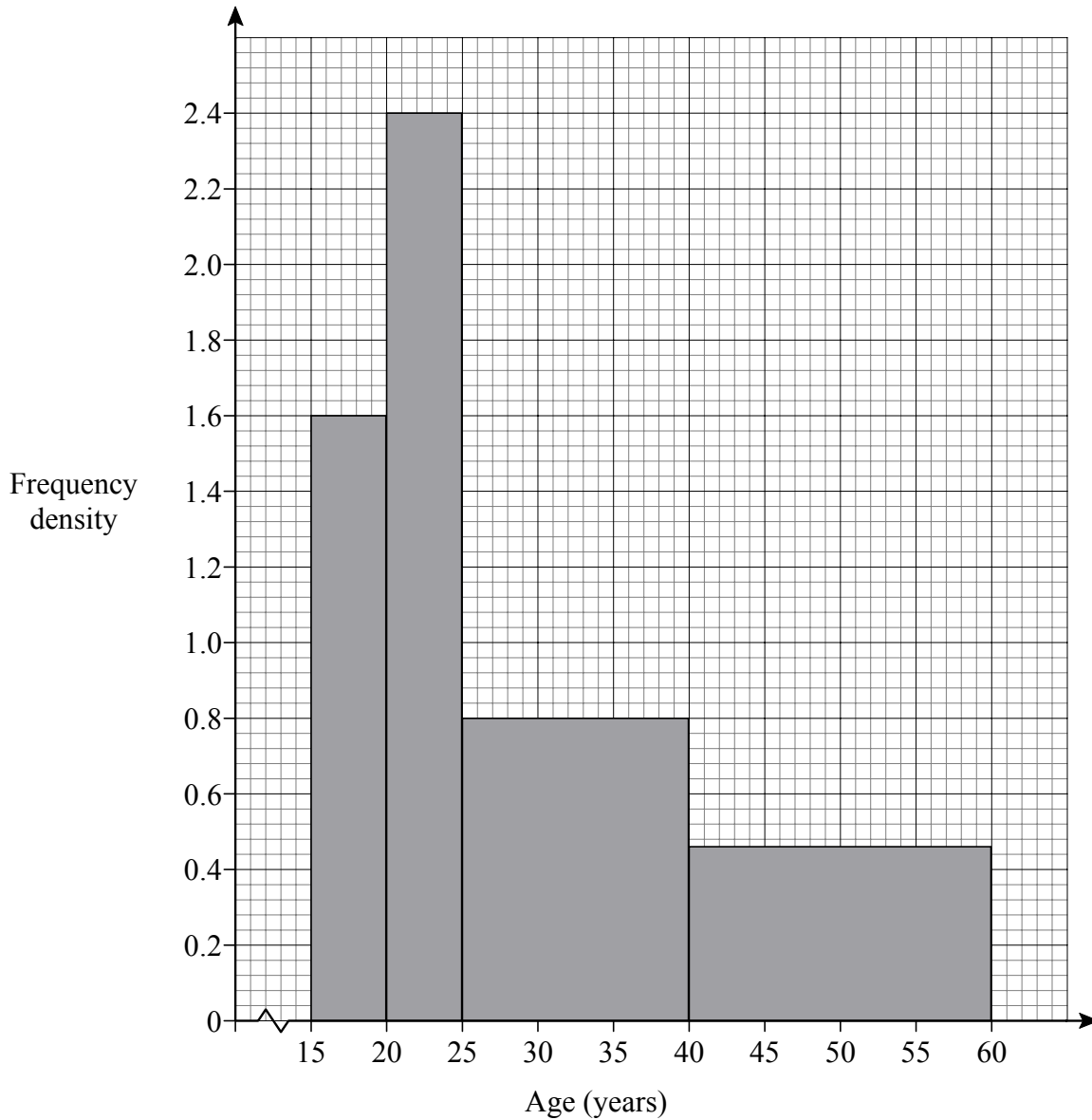

3 (a) Of all the workers under 25 years old, what percentage are under 20 years old?

.....

.....

Answer % (2 marks)

- 3 (b) The table shows the age distribution of the workers in the office.

Age, x in years	Frequency
$15 \leq x < 20$	1
$20 \leq x < 25$	10
$25 \leq x < 40$	12
$40 \leq x < 60$	17

Draw a histogram to show this data.

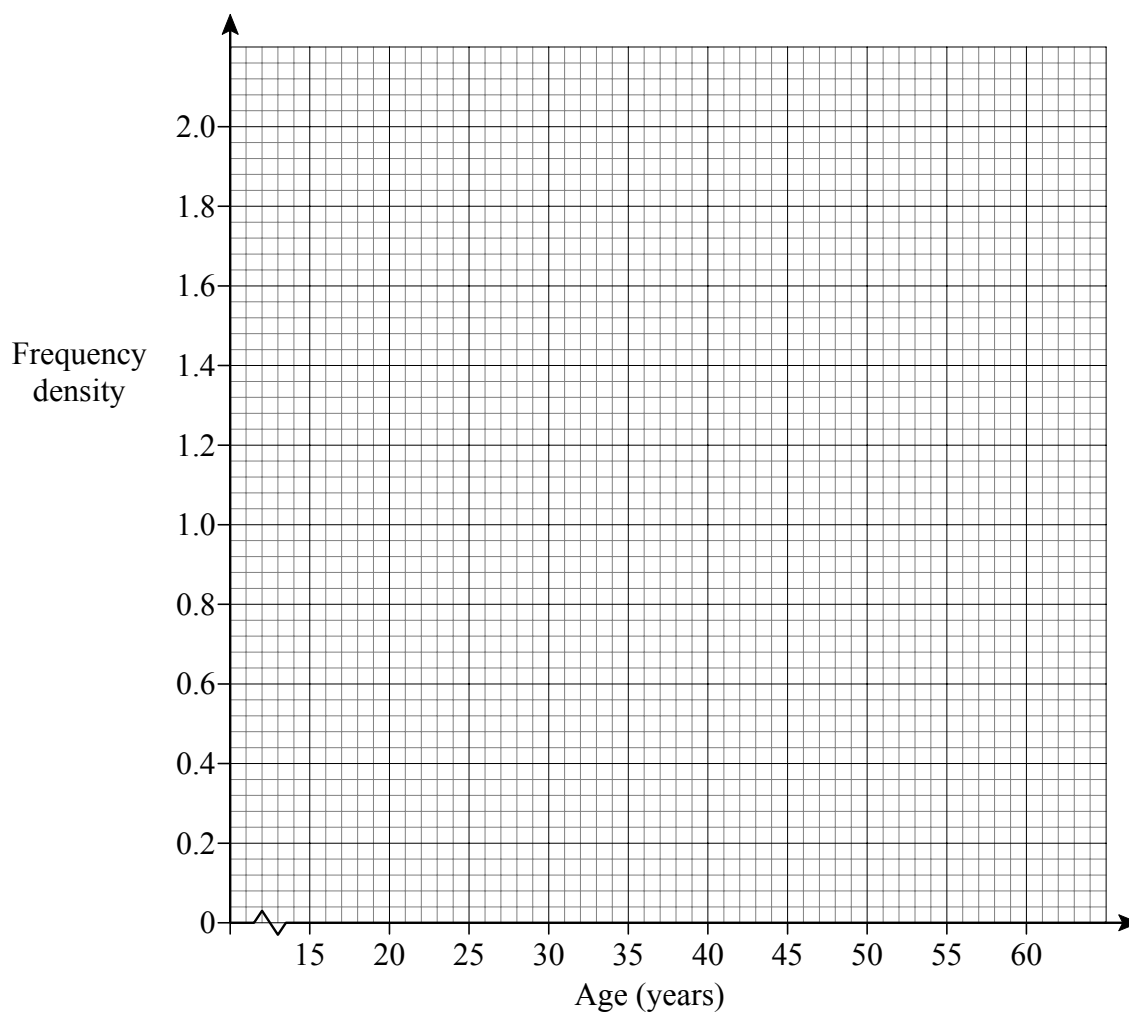

(3 marks)

- 3 (c) Write down one difference in the age distributions of the workers in the bank and the office.

.....

.....

(1 mark)

4 When petrol is sold, the money from the sale is divided into the following ratio.

Tax : Oil Company : Petrol Station
35 : 11 : 4

4 (a) How many pence of every pound spent on petrol is tax?

.....
Answer pence (1 mark)

4 (b) One week a petrol station sells petrol of total value £ 17 680

4 (b) (i) Calculate how much of this goes to the oil company.

.....
.....
Answer £ (2 marks)

4 (b) (ii) You are given that £ 17 680 was rounded to the nearest £ 10
The cost of petrol is 124p per litre to the nearest penny.

Calculate the maximum number of litres of petrol sold that week.

.....
.....
.....
Answer litres (3 marks)

6

END OF SECTION A

Surname					Other Names				
Centre Number					Candidate Number				
Candidate Signature									

For Examiner's Use

General Certificate of Secondary Education

MATHEMATICS (PILOT)
Unit 2 Higher Tier Section B

93002/HB

H



Specimen Paper (Curriculum Pathways Pilot) 2009

<p>For this paper you must have:</p> <ul style="list-style-type: none"> mathematical instruments <p>You must not use a calculator.</p>	
---	--

Time allowed For Section B: 30 minutes

Instructions

- Use black ink or black ball-point pen. Draw diagrams in pencil.
- Fill in the boxes at the top of this page.
- Answer **all** questions.
- You must answer questions in the spaces provided. Answers written in margins will not be marked.
- Do all rough work in this book.
- You may not use your calculator in Section B. Your calculator must remain on the floor under your seat.
- When you have answered Section B you may work again on Section A but you may **not** use your calculator. It must remain on the floor under your seat.
- At the end of the examination tag Section A and Section B together with Section A on top.

Information

- The maximum mark for Section B is 25.
- The marks for questions are shown in brackets.
- You may ask for more answer paper and graph paper. These must be tagged securely to this answer book.

Advice

- In all calculations, show clearly how you work out your answer.

**DO NOT WRITE ON THIS PAGE
ANSWER IN THE SPACES PROVIDED**

Answer **all** questions in the spaces provided.

5 (a) Work out $\frac{7}{10} + \frac{1}{4}$

.....
.....
.....

Answer (2 marks)

5 (b) Work out $10 \times \frac{1}{4}$

Write your answer as a mixed number in its simplest form.

.....
.....

Answer (2 marks)

5 (c) Work out $4.3 + 2 \times 0.01$

.....
.....

Answer (2 marks)

6

Turn over for the next question

- 6 The table shows the number of each colour of ball used in a game of snooker. These balls are stored in a box.

Colour	Red	Yellow	Green	Brown	Blue	Pink	Black	White
Number	15	1	1	1	1	1	1	1

- 6 (a) In an experiment a ball is chosen at random from the box. The colour is noted and the ball is then replaced in the box. This experiment is repeated 110 times.

How many times would you expect a red ball to be chosen?

.....
.....

Answer (2 marks)

- 6 (b) One ball is chosen at random from the box containing these balls. It is then replaced in the box. A second ball is then chosen at random from the box.

Show that the probability that the first ball is yellow and the second ball is pink or black is $\frac{1}{242}$

.....
.....
.....

(2 marks)

- 7 (a) Write down the number 230 000 in standard form.

Answer (1 mark)

- 7 (b) Write 7.2×10^{-2} as an ordinary number.

Answer (1 mark)

4

2

8 A questionnaire about holiday destinations is sent out to a sample of houses in a town.

8 (a) (i) Write down **one** practical problem that can occur when collecting data by sending out a questionnaire.

.....
.....

(1 mark)

8 (a) (ii) Suggest **one** way of dealing with the problem you wrote down in part (i).

.....
.....

(1 mark)

8 (b) The sample is stratified according to house price.
Explain why this stratified sample has been used.

.....
.....

(1 mark)

8 (c) In the sample there are 40 houses in the price range £ 100 000 to £ 200 000
In the town there are 8000 houses in that price range.
The 40 houses in the sample were chosen at random from the 8000 houses in the town.
Explain how this random sample could be chosen.

.....
.....
.....

(2 marks)

5

9 The table shows some information about the number of visitors to a theme park.

Year	Quarter	Number of visitors (in thousands)	4-Point Moving Average (in thousands to the nearest thousand)
2006	Q1	35	
	Q2	128	
	Q3	232	121
	Q4	89	120
2007	Q1	32	118
	Q2	119	112
	Q3	208	109
	Q4	77	109
2008	Q1	32	105
	Q2	103	100
	Q3	188	
	Q4		

The graph shows this time series data for 2006 and 2007.

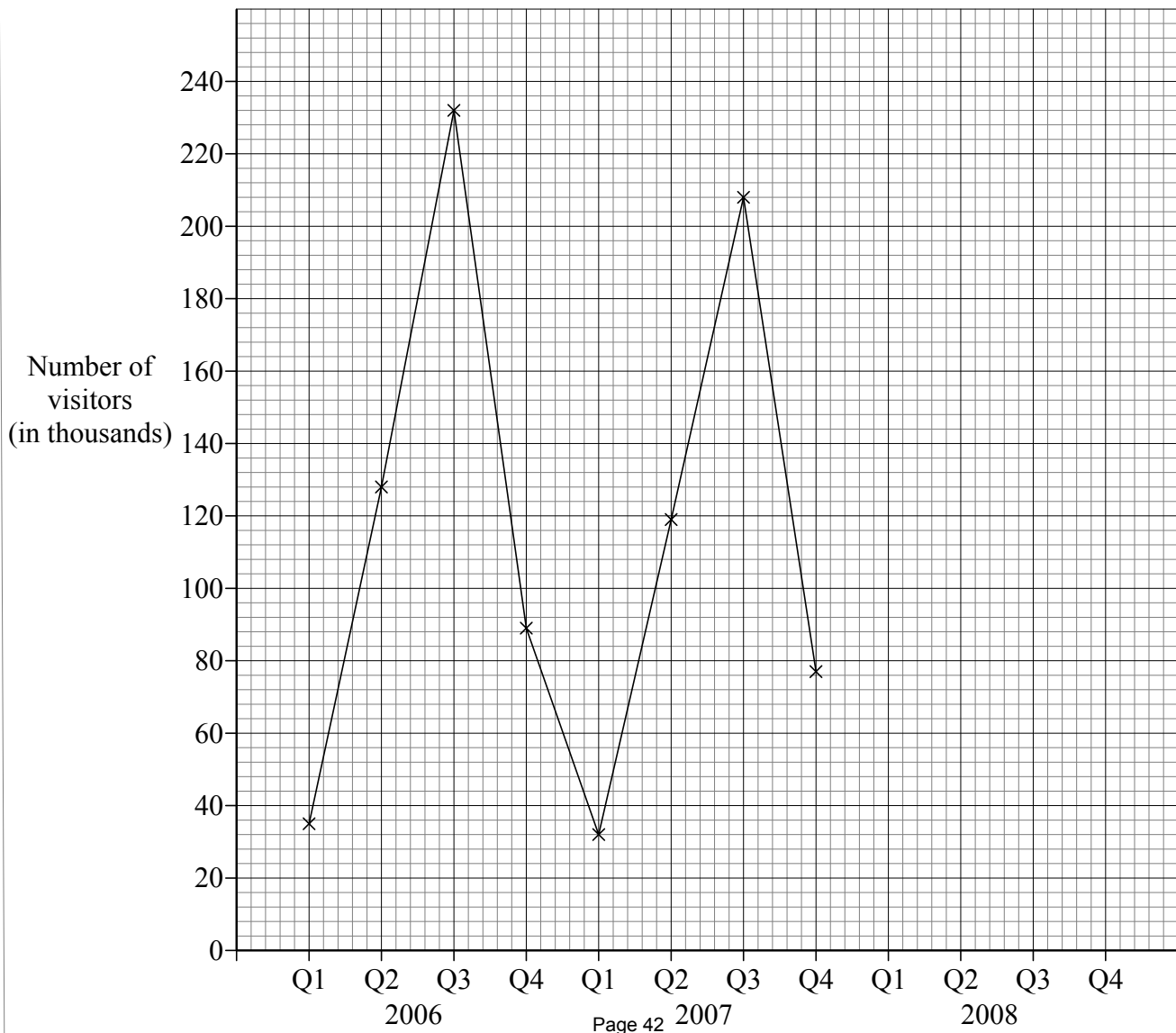

9 (a) Complete the graph using the 2008 data for Q1, Q2 and Q3

(2 marks)

9 (b) Explain why a 4-point moving average is appropriate.

.....
.....

(1 mark)

9 (c) Estimate the number of visitors in Q4 for 2008.

.....
.....
.....
.....
.....
.....

Answer thousand (5 marks)

8

END OF QUESTIONS

There are no questions printed on this page

**DO NOT WRITE ON THIS PAGE
ANSWER IN THE SPACES PROVIDED**



ASSESSMENT and
QUALIFICATIONS
ALLIANCE

General Certificate of Secondary Education

Mathematics (Pilot) 9307

Unit 2, Higher Tier, Sections A and B

Mark Scheme

Specimen Paper

Mark schemes are prepared by the Principal Examiner and considered, together with the relevant questions, by a panel of subject teachers. This mark scheme includes any amendments made at the standardisation meeting attended by all examiners and is the scheme which was used by them in this examination. The standardisation meeting ensures that the mark scheme covers the candidates' responses to questions and that every examiner understands and applies it in the same correct way. As preparation for the standardisation meeting each examiner analyses a number of candidates' scripts: alternative answers not already covered by the mark scheme are discussed at the meeting and legislated for. If, after this meeting, examiners encounter unusual answers which have not been discussed at the meeting they are required to refer these to the Principal Examiner.

It must be stressed that a mark scheme is a working document, in many cases further developed and expanded on the basis of candidates' reactions to a particular paper. Assumptions about future mark schemes on the basis of one year's document should be avoided; whilst the guiding principles of assessment remain constant, details will change, depending on the content of a particular examination paper.

Further copies of this Mark Scheme are available to download from the AQA Website: www.aqa.org.uk

Copyright © 2008 AQA and its licensors. All rights reserved.

The Assessment and Qualifications Alliance (AQA) is a company limited by guarantee registered in England and Wales 3644723 and registered charity number 1073334.
Registered address AQA, Devas Street, Manchester M15 6EX *Dr Michael Cresswell Director General.*

Glossary for Mark Schemes

GCSE examinations are marked in such a way as to award positive achievement wherever possible. Thus, for GCSE Mathematics papers, marks are awarded under various categories.

- M** Method marks are awarded for a correct method which could lead to a correct answer.
- A** Accuracy marks are awarded when following on from a correct method. It is not necessary to always see the method. This can be implied.
- B** Marks awarded independent of method.
- D** Marks awarded independent of method for correct use of data sheet.
- M dep** A method mark dependent on a previous method mark being awarded.
- B dep** A mark that can only be awarded if a previous independent mark has been awarded.
- ft** Follow through marks. Marks awarded following a mistake in an earlier step.
- SC** Special case. Marks awarded within the scheme for a common misinterpretation which has some mathematical worth.
- oe** Or equivalent. Accept answers that are equivalent.
eg, accept 0.5 as well as $\frac{1}{2}$

Section A

Q	Answer	Mark	Comments																					
1	$\frac{110.25}{5.25} = 21$	B1																						
	$\frac{110.25 - 10.50}{5.25}$	M1																						
	19	A1																						
2(a)	$\frac{4}{40}$	B1	oe																					
2(b)	Ticks 2 nd , 3 rd and 4 th boxes	B2	B1 For two correct and none wrong																					
2(c)(i)	Identifies 21 st value as median (Accept 21.5 th)	M1	Work on mean or median in either order. Also can award B1 B1 for modes correct (instead of either mean or median)																					
	7	A1	<table border="1"> <thead> <tr> <th>Hourly wage (£)</th> <th>Frequency</th> <th>fx</th> </tr> </thead> <tbody> <tr> <td>6</td> <td>18</td> <td>108</td> </tr> <tr> <td>7</td> <td>10</td> <td>70</td> </tr> <tr> <td>8</td> <td>6</td> <td>48</td> </tr> <tr> <td>9</td> <td>4</td> <td>36</td> </tr> <tr> <td>10</td> <td>2</td> <td>20</td> </tr> <tr> <td colspan="2"></td> <td>$\Sigma = 282$</td> </tr> </tbody> </table>	Hourly wage (£)	Frequency	fx	6	18	108	7	10	70	8	6	48	9	4	36	10	2	20			$\Sigma = 282$
	Hourly wage (£)	Frequency		fx																				
	6	18		108																				
	7	10		70																				
8	6	48																						
9	4	36																						
10	2	20																						
		$\Sigma = 282$																						
One correct example of ' fx '	M1																							
Attempts to total and dividing by 40	M1dep																							
£7.05	A1																							
2(c)(ii)	Some earn £10 at Superspend or higher relative frequency of £9	B1	oe																					
2(c)(iii)	Mean / median higher at Shopsave or fewer earn £6	B1	oe Could also refer to mode(s)																					

Q	Answer	Mark	Comments
3(a)	$\frac{1.6}{4} \times 100$	M1	or $\frac{16}{40} \times 100$
	40	A1	
3(b)	All frequency densities correct	B2	0.2, 2, 0.8, 0.85 B1 For any one fd correct
	Graph drawn for their frequency densities or original frequencies as long as no gaps	B1	All heights and widths correct ft
3(c)	Any sensible comment	B1	eg, more younger workers in bank more older workers in office or can focus on a particular age group

4(a)	70	B1	
4(b)(i)	$\frac{11}{50} \times 17680$	M1	
	3889.60	A1	
4(b)(ii)	Sight of any correct bound	B1	17 675, 17 684.99, 123.5, 124.5 or 124.499... using accepted recurring notation or same in pounds
	Their max total/their minimum cost per litre	M1	$\frac{17684.99}{1.235}$ if correct
	14 319.8	A1	Accept 14 300 or better with working

Section B

5(a)	Appropriate common denominator with at least one correct numerator	M1	eg, $\frac{14}{20} + \frac{5}{20}$
	$\frac{19}{20}$	A1	
5(b)	$2\frac{1}{2}$	B2	B1 $\frac{10}{4}$ or $2\frac{2}{4}$ or $\frac{5}{2}$ or 2.5
5(c)	4.32	B2	oe B1 4.3 + 0.02 SC1 0.063

Q	Answer	Mark	Comments
6(a)	$\frac{15}{22} \times 100$	M1	15×5
	75	A1	
6(b)	$\frac{1}{22}, \frac{2}{22}$	B1	Both seen
	Evidence of multiplication required	B1	B2 $\frac{1}{22} \times \frac{2}{22}$ oe
7(a)	2.3×10^5	B1	
7(b)	0.072	B1	
8(a)(i)	Non-response	B1	Misunderstanding of questions incomplete returns ie, missing data oe sensible
8(a)(ii)	Collect questionnaires from houses	B1	Must address their answer from (i) Accept suggestion of use of a better (named) method
8(b)	Responses are likely to be very different between people from different economic means	B1	oe
8(c)	Number or list the 8000 (eg, on spreadsheet/database)	B1	
	Select random numbers from eg, calculator/computer to obtain sample of 40	B1	

Q	Answer	Mark	Comments
9(a)	Plots the 2008 data correctly	B2	B1 Two correct plots
9(b)	There are 4 sets of data per year	E1	
9(c)	Correct vertical plots	B1	
	Correct horizontal plots	B1	eg, 1 st moving average should be plotted halfway between Q2 and Q3 2006
	Draws a trend line as a line of best fit 'through' their moving averages plots	M1	Award generously
	Reads off their extended trend line at point between Q2 and Q3 2008	M1dep	
	Finds estimate of Q4 2008 using above	A1	

Surname						Other Names					
Centre Number						Candidate Number					
Candidate Signature											

For Examiner's Use

General Certificate of Secondary Education

MATHEMATICS (PILOT)
Unit 3 Foundation Tier
Paper 1 Non-Calculator

93003/1F

F



Specimen Paper (Curriculum Pathways Pilot 2009)

<p>For this paper you must have:</p> <ul style="list-style-type: none"> mathematical instruments <p>You must not use a calculator.</p>	
---	--

For Examiner's Use	
Pages	Mark
3	
4 – 5	
6 – 7	
8 – 9	
10 – 11	
12	
TOTAL	
Examiner's Initials	

Time allowed: 1 hour

Instructions

- Use black ink or black ball-point pen. Draw diagrams in pencil.
- Fill in the boxes at the top of this page.
- Answer **all** questions.
- You must answer the questions in the spaces provided. Answers written in margins or on blank pages will not be marked
- Do all rough work in this book.

Information

- The maximum mark for this paper is 50.
- The marks for questions are shown in brackets.
- You may ask for more answer paper, graph paper and tracing paper. This must be tagged securely to this answer book.

Advice

- In all calculations, show clearly how you work out your answer.

Formulae Sheet: Foundation Tier

Area of trapezium = $\frac{1}{2}(a+b)h$

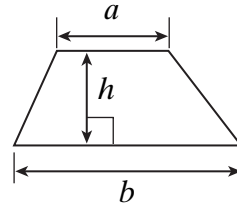

Volume of prism = area of cross-section \times length

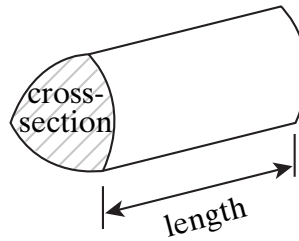

Answer **all** questions in the spaces provided.

1 Here are two shapes.

Rectangle



Isosceles Trapezium

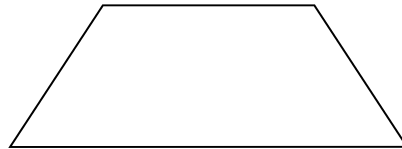

Write down **two** things that are the same and **two** things that are different about these shapes.

Same

Same

Different

Different

(4 marks)

Turn over for the next question

- 2 (a) Use **two** whole numbers to write down a calculation with answer 3.5

.....

Answer (1 mark)

- 2 (b) Use **three** whole numbers to write down a calculation with answer 3.5

.....

Answer (1 mark)

- 2 (c) Work out 3.5×0.1

.....

Answer (1 mark)

- 3 Here are three numbers.

25 30 36

Give a reason why each number could be the odd one out.

Answer

25 is the odd one out because

.....

30 is the odd one out because

.....

36 is the odd one out because

.....

(3 marks)

4 A hire company uses this formula to work out the charges for a carpet cleaner.

$$\text{Total cost} = \text{£}24.50 \text{ for the first day} + \text{£}12.25 \text{ for each extra day}$$

4 (a) How much does it cost to hire the cleaner for three days?

.....
.....
.....

Answer £ (2 marks)

4 (b) The company introduces **two** special offers.

Offer 1: Weekend rate £30

Offer 2: Hire for any five consecutive days for £60

4 (b) (i) How much will be saved using Offer 1 instead of the normal charge for two days?

.....
.....
.....
.....

Answer £ (2 marks)

4 (b) (ii) A cleaning job will take four days.

Should I use Offer 2 or pay the normal charge for four days?
You **must** show your working.

.....
.....
.....
.....

Answer (2 marks)

5 The diagram shows a kitchen wall and a rectangular tile.

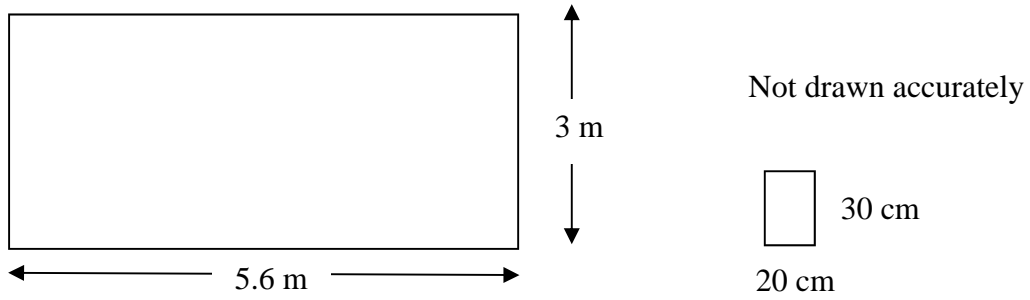

(a) The wall is to be tiled using rectangular tiles which are 20 centimetres wide and 30 centimetres high.

Work out the minimum number of tiles needed to cover the wall.

.....

.....

.....

.....

.....

Answer (4 marks)

(b) A radiator 1.8 metres long is fitted to the wall. The radiator is the same distance from each end of the wall as shown.

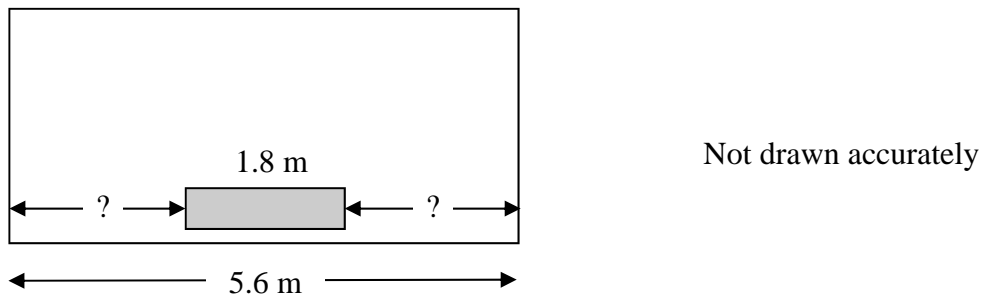

How far is it from the end of the radiator to a wall?

.....

.....

.....

Answer metres (3 marks)

6 (a) Plot the points $A(3, 2)$, $B(4, 8)$, $C(8, 6)$ and $D(7, 0)$ on the grid.

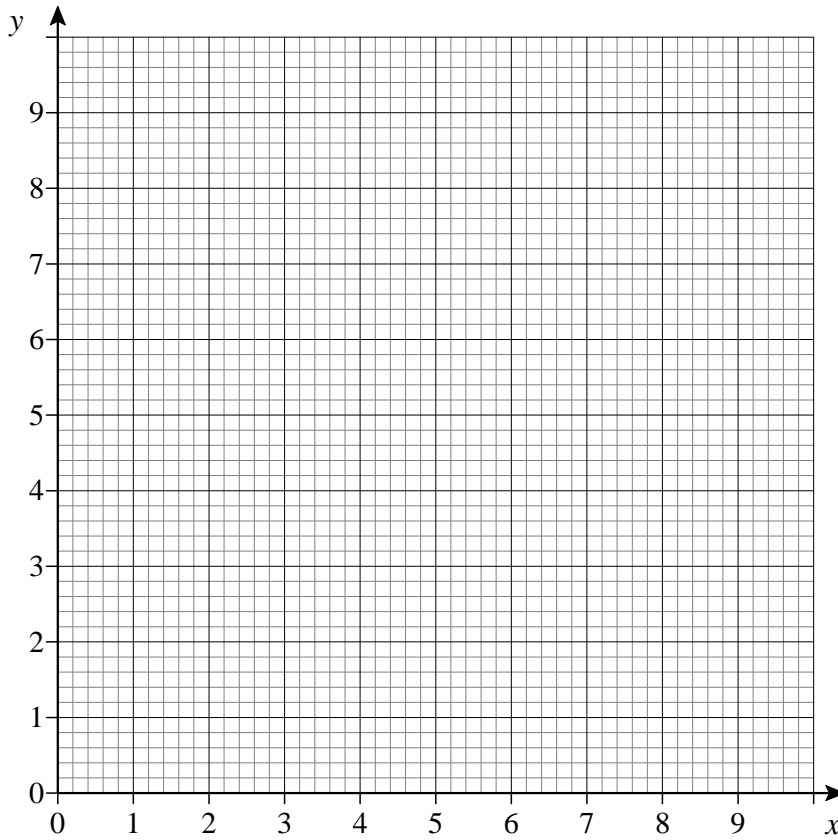

(2 marks)

6 (b) Join the points to form shape $ABCD$.

(1 mark)

6 (c) Write down the name of shape $ABCD$.

Answer (1 mark)

6 (d) Write down **two** facts about the symmetry of shape $ABCD$.

Fact 1

.....

Fact 2

.....

(2 marks)

7 A town has 7500 households.
If a household turns down the thermostat by 1°C, it saves 300 kg of carbon dioxide per year.

Work out the amount of carbon dioxide saved per year if one in every five households turns down the thermostat by 1°C.
Give your answer in tonnes.

.....

.....

.....

.....

.....

.....

.....

Answer tonnes (4 marks)

8 $V = 3x - 8y$

- 8** (a) Work out the value of V when $x = 2$ and $y = -5$

.....

Answer (2 marks)

- 8** (b) Rearrange the formula $V = 3x - 8y$ to make x the subject.

.....

Answer $x =$ (2 marks)

- 9** (a) Multiply out and simplify $3x + 4(x - 1)$

.....

Answer (2 marks)

- 9** (b) Simplify $\frac{y^3 \times y^7}{y^5}$

.....

Answer (2 marks)

- 10** The diagram shows a sketch of a lawn.
There is an electrical power point at *C*.
An electric lawnmower has a cable of length 15 metres.

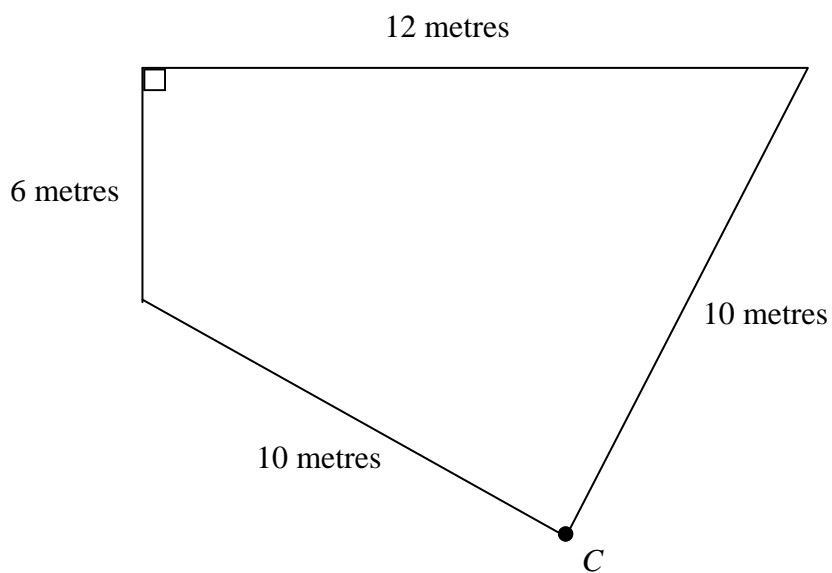

Not drawn accurately

By making an accurate scale drawing of the lawn on the page opposite show that the cable is long enough for the whole lawn to be mowed.
Use a scale of 1 centimetre to represent 1 metre.
One side has been drawn for you.

1 cm represents 1 m

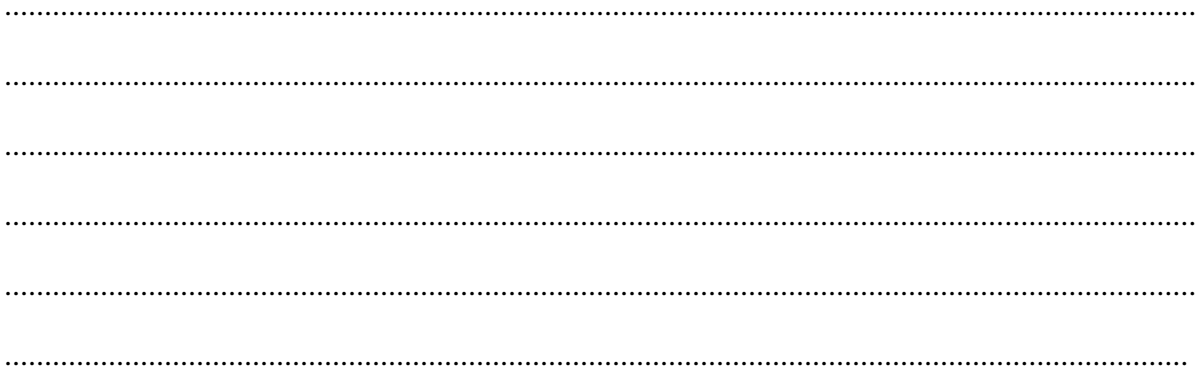

(4 marks)

4

- 11 (a) A gardener states that the number of plants (p) grown this year was less than 500.

Write this statement as an inequality.

Answer (1 mark)

- 11 (b) He also states that the number of plants grown last year was twice as many as this year.

Write the number of plants grown last year as an expression in terms of p .

Answer (1 mark)

- 11 (c) The total number of plants grown for both years is greater than 1400.

How many plants could he have grown this year?

Give **two** possible answers.

.....
.....
.....
.....

Answer or (3 marks)

END OF QUESTIONS



ASSESSMENT and
QUALIFICATIONS
ALLIANCE

General Certificate of Secondary Education

Mathematics (Pilot) 9307

Unit 3, Foundation Tier, Paper 1

Mark Scheme

Specimen Paper

Mark schemes are prepared by the Principal Examiner and considered, together with the relevant questions, by a panel of subject teachers. This mark scheme includes any amendments made at the standardisation meeting attended by all examiners and is the scheme which was used by them in this examination. The standardisation meeting ensures that the mark scheme covers the candidates' responses to questions and that every examiner understands and applies it in the same correct way. As preparation for the standardisation meeting each examiner analyses a number of candidates' scripts: alternative answers not already covered by the mark scheme are discussed at the meeting and legislated for. If, after this meeting, examiners encounter unusual answers which have not been discussed at the meeting they are required to refer these to the Principal Examiner.

It must be stressed that a mark scheme is a working document, in many cases further developed and expanded on the basis of candidates' reactions to a particular paper. Assumptions about future mark schemes on the basis of one year's document should be avoided; whilst the guiding principles of assessment remain constant, details will change, depending on the content of a particular examination paper.

Further copies of this Mark Scheme are available to download from the AQA Website: www.aqa.org.uk

Copyright © 2008 AQA and its licensors. All rights reserved.

The Assessment and Qualifications Alliance (AQA) is a company limited by guarantee registered in England and Wales 3644723 and registered charity number 1073334.
Registered address AQA, Devas Street, Manchester M15 6EX *Dr Michael Cresswell Director General.*

Glossary for Mark Schemes

GCSE examinations are marked in such a way as to award positive achievement wherever possible. Thus, for GCSE Mathematics papers, marks are awarded under various categories.

- M** Method marks are awarded for a correct method which could lead to a correct answer.
- A** Accuracy marks are awarded when following on from a correct method. It is not necessary to always see the method. This can be implied.
- B** Marks awarded independent of method.
- D** Marks awarded independent of method for correct use of data sheet.
- M dep** A method mark dependent on a previous method mark being awarded.
- B dep** A mark that can only be awarded if a previous independent mark has been awarded.
- ft** Follow through marks. Marks awarded following a mistake in an earlier step.
- SC** Special case. Marks awarded within the scheme for a common misinterpretation which has some mathematical worth.
- oe** Or equivalent. Accept answers that are equivalent.
eg, accept 0.5 as well as $\frac{1}{2}$

Unit 3, Foundation Tier, Paper 1

Q	Answer	Mark	Comments
1	Same properties	B1 B1	eg, Four sides Four (interior) angles Parallel sides Both quadrilaterals Line symmetry
	Different properties	B1 B1	eg, Rectangle has right angles Rectangle has both sets of opposite sides parallel Rectangle has 2 lines of symmetry or trapezium has only 1 line of symmetry
2(a)	Correct calculation using two integers	B1	eg, $7 \div 2$
2(b)	Correct calculation using three integers	B1	eg, $(3 + 4) \div 2$
2(c)	0.35	B1	oe
3	Valid reason for 25 with implication that 30 and 36 have a common property	B1	eg, The only odd number Not a multiple of 6
	Valid reason for 30 with implication that 25 and 36 have a common property	B1	eg, The only number that is not a square number
	Valid reason for 36 with implication that 25 and 30 have a common property	B1	eg, Not a multiple of 5
4(a)	$24.5(0) + 12.25 + 12.25$	M1	oe
	49	A1	
4(b)(i)	Normal = $24.5 + 12.25 (= 36.75)$	M1	
	(Saving =) £6.75	A1	
4(b)(ii)	Normal = $24.5 + 3 \times 12.25$	M1	
	61.25 and Offer is £1.25 cheaper or Choose offer 2	A1	oe

Q	Answer	Mark	Comments
5(a)	$300 \div 30$ or 10	M1	
	$560 \div 20$ or 28	M1	
	10×28	M1dep	
	280	A1	
5(b)	$5.6 - 1.8 (= 3.8)$	M1	$1.8 \div 2 (= 0.9)$
	$(5.6 - 1.8) \div 2$ or $3.8 \div 2$	M1dep	$5.6 \div 2 - 0.9$ or $2.8 - 0.9$
	1.9	A1	
6(a)	Points plotted correctly	B2	B1 For 3 correct points
6(b)	Their points joined to form a quadrilateral	B1	
6(c)	Parallelogram	B1	
6(d)	Two symmetry properties for a parallelogram	B1	No lines of symmetry
		B1	Rotational symmetry order 2
7	$7500 \div 5$ or 1500	M1	
	Their 1500×300	M1dep	
	450 000	A1	
	450	B1ft	ft Their kg $\div 1000$
8(a)	$3 \times 2 - 8 \times -5$ or $6 + 40$	M1	
	46	A1	
8(b)	$V + 8y$	M1	
	$\frac{V + 8y}{3}$	A1	

Q	Answer	Mark	Comments
9(a)	$4x - 4$	M1	
	$7x - 4$	A1	
9(b)	y^{10}	M1	
	y^5	A1	
10	Using overlay: All points in tolerance and shape completed	B3	B2 For one error B1 For two errors or for one side correct length or one vertex correct
	Valid conclusion	B1	eg, Stated that length = [13.4, 13.6]
11(a)	$p < 500$	B1	oe
11(b)	$2p$	B1	
11(c)	$2p + p > 1400$	M1	
	$p > 466(\dots)$	A1	
	Two values for p such that $466 < p < 500$	A1	One correct value implies M1A1A0

Surname						Other Names					
Centre Number						Candidate Number					
Candidate Signature											

For Examiner's Use

General Certificate of Secondary Education

MATHEMATICS (PILOT)
Unit 3 Higher Tier
Paper 1 Non-Calculator

93003/1H

H



Specimen Paper (Curriculum Pathways Pilot 2009)

<p>For this paper you must have:</p> <ul style="list-style-type: none"> mathematical instruments <p>You must not use a calculator.</p>	
---	--

For Examiner's Use	
Pages	Mark
3	
4 – 5	
6 – 7	
8 – 9	
10 – 11	
12	
TOTAL	
Examiner's Initials	

Time allowed: 1 hour

Instructions

- Use black ink or black ball-point pen. Draw diagrams in pencil.
- Fill in the boxes at the top of this page.
- Answer **all** questions.
- You must answer the questions in the spaces provided. Answers written in margins or on blank pages will not be marked
- Do all rough work in this book.

Information

- The maximum mark for this paper is 50.
- The marks for questions are shown in brackets.
- You may ask for more answer paper, graph paper and tracing paper. This must be tagged securely to this answer book.

Advice

- In all calculations, show clearly how you work out your answer.

Formulae Sheet: Higher Tier

Area of trapezium = $\frac{1}{2}(a+b)h$

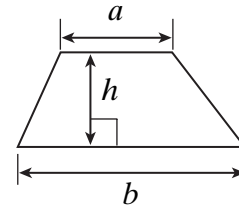

Volume of prism = area of cross-section \times length

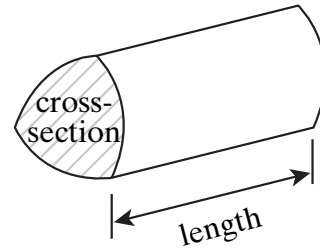

Volume of sphere = $\frac{4}{3} \pi r^3$

Surface area of sphere = $4 \pi r^2$

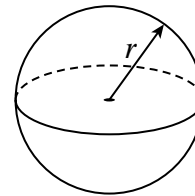

Volume of cone = $\frac{1}{3} \pi r^2 h$

Curved surface area of cone = $\pi r l$

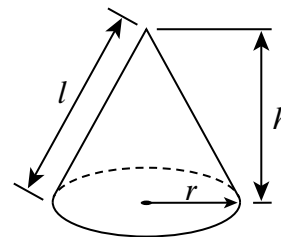

In any triangle ABC

Area of triangle = $\frac{1}{2} ab \sin C$

Sine rule $\frac{a}{\sin A} = \frac{b}{\sin B} = \frac{c}{\sin C}$

Cosine rule $a^2 = b^2 + c^2 - 2bc \cos A$

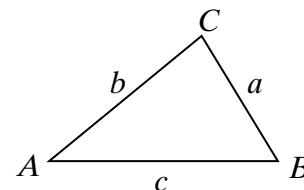

The Quadratic Equation

The solutions of $ax^2 + bx + c = 0$, where $a \neq 0$, are given by

$$x = \frac{-b \pm \sqrt{(b^2 - 4ac)}}{2a}$$

Answer **all** questions in the spaces provided.

1 A hire company uses this formula to work out the charges for a carpet cleaner.

$$C = 24.50 + 12.25(n - 1)$$

C is the charge in pounds.

n is the number of days the carpet cleaner is hired.

1 (a) How much does it cost to hire the cleaner for three days?

.....
.....
.....

Answer £ (2 marks)

1 (b) The company introduces **two** special offers.

Offer 1: Weekend rate £30

Offer 2: Hire for any five consecutive days for £60

1 (b) (i) How much will be saved using Offer 1 instead of the normal charge for two days?

.....
.....
.....

Answer £ (2 marks)

1 (b) (ii) A cleaning job will take four days.

Should I use Offer 2 or pay the normal charge for four days?

You **must** show your working.

.....
.....
.....
.....

Answer (2 marks)

2 The diagram shows a kitchen wall and a rectangular tile.

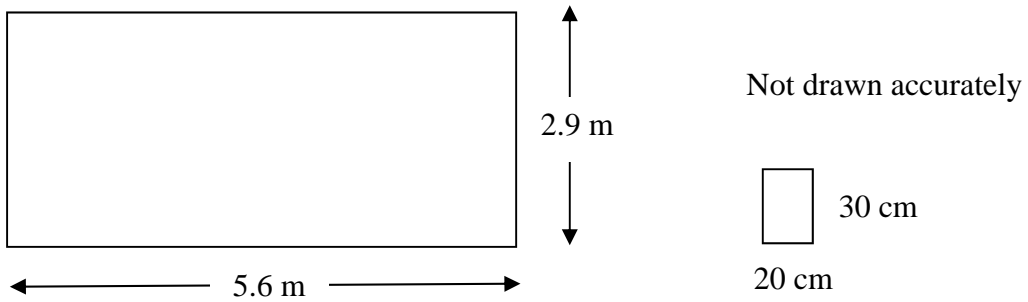

2 (a) The wall is to be tiled using rectangular tiles which are 20 centimetres wide and 30 centimetres high. Any part used tiles are thrown away.

Work out the minimum number of tiles needed to cover the wall.

.....

.....

.....

.....

.....

Answer (4 marks)

2 (b) A radiator 1.7 metres long is fitted to the wall. The radiator is twice as far from the left wall as from the right wall.

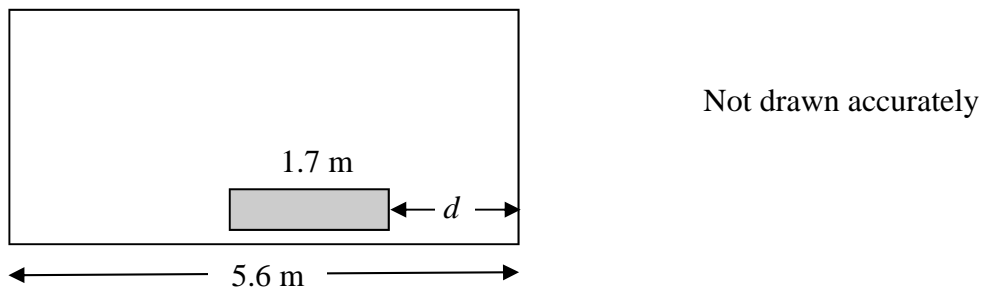

Find the distance from the right wall, marked d on the diagram.

.....

.....

.....

Answer metres (3 marks)

- 3 (a) Multiply out and simplify $3x + 4(x - 1)$

.....

Answer (2 marks)

- 3 (b) Rearrange the formula $V = 3x - 8y$ to make x the subject.

.....

.....

.....

Answer (2 marks)

- 3 (c) Simplify $\frac{y^3 \times y^7}{y^5}$

.....

.....

Answer (2 marks)

Turn over for the next question

- 4 (a) A gardener states that the number of plants (p) grown this year was less than 500.

Write this statement as an inequality.

Answer (1 mark)

- 4 (b) He also states that the number of plants grown last year was twice as many as this year.

Write the number of plants grown last year as an expression in terms of p .

Answer (1 mark)

- 4 (c) The total number of plants grown for both years is greater than 1400.

How many plants could he have grown this year?

Give **two** possible answers.

.....
.....
.....
.....

Answer or (3 marks)

5 In the expressions below x , y and z represent lengths.

State whether each of the expressions could represent length, area, volume or none of these.

5 (a) $xy - z$

Answer (1 mark)B

5 (b) x^2z

Answer (1 mark)B

5 (c) $y + z - x$

Answer (1 mark)B

6 The diagram shows two similar triangles.

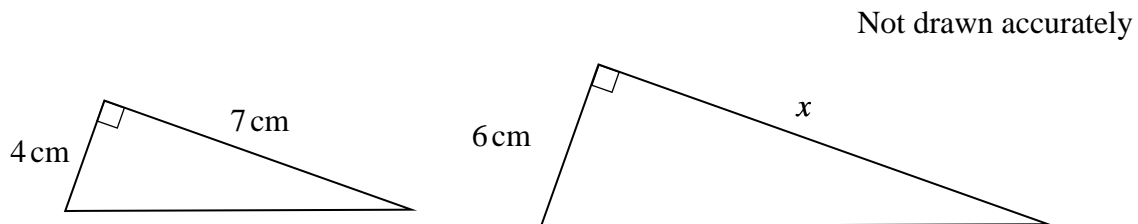

Work out the value of x .

.....

.....

.....

.....

.....

Answer cm (3 marks)

7 (a) The diagram show a circle with a tangent ATB .

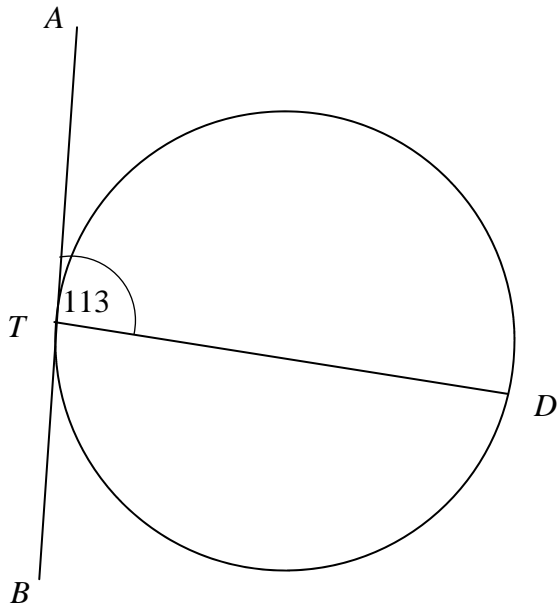

Not drawn accurately

Explain how you know that TD is **not** a diameter of the circle.

.....

(1 mark)

7 (b) The diagram shows a cyclic quadrilateral.

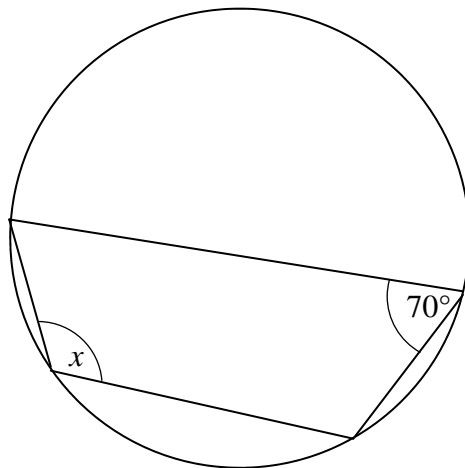

Not drawn accurately

Work out the value of x .

.....

Answer degrees (1 mark)

- 7 (c) The diagram show a circle with a tangent ATB .

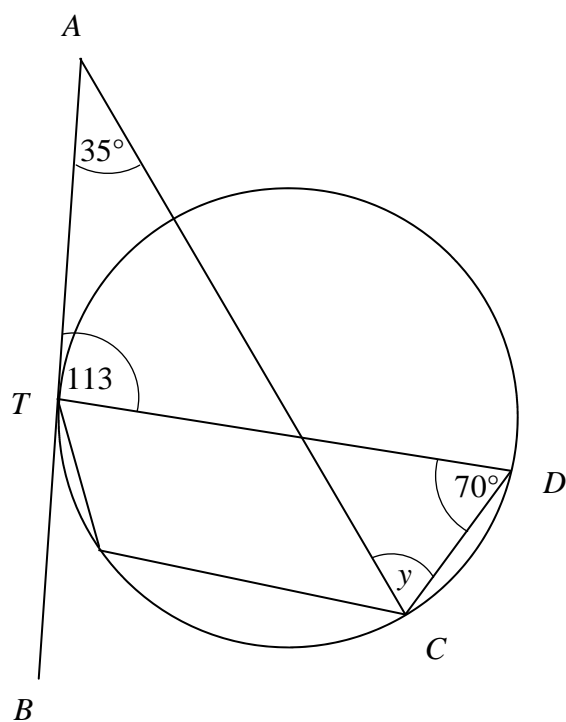

Not drawn accurately

Work out the value of y .

.....

.....

Answer degrees (2 marks)

Turn over for the next question

8 (a) Show that $(x - 9)(x + 2) \equiv x^2 - 7x - 18$

.....
.....

(1 mark)

8 (b) Simplify $\frac{x^2 - 4}{x^2 - 7x - 18}$

.....
.....
.....

Answer (2 marks)

9 The height of a cuboid is 10 cm.
The length of the cuboid is twice its width.
The surface area of the cuboid is 504 cm².

Work out the width of the cuboid.

.....
.....
.....
.....
.....
.....
.....
.....
.....
.....

Answer cm (5 marks)

- 10 The diagram shows two identical square-based pyramids put together to make an octahedron.

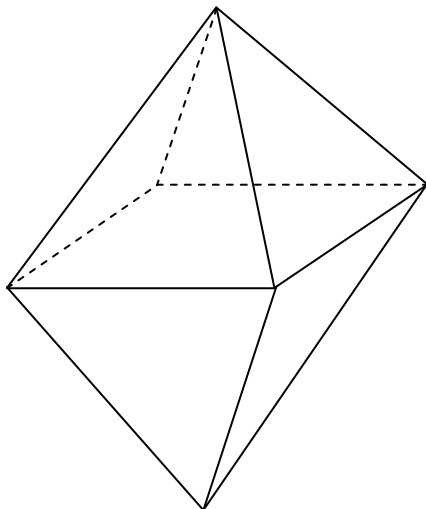

The area of the base of each pyramid is 20 cm^2
 The volume of the octahedron is 84 cm^3 .

You are given the formula

$$\text{Volume of a pyramid} = \frac{1}{3} \times \text{area of base} \times \text{vertical height.}$$

Work out the height of octahedron.

.....

.....

.....

.....

.....

Answer cm (3 marks)

11 Here is an equation $y = \frac{2x+7}{\sqrt{9-4x^2}}$

11 (a) The graph of this equation intersects the x -axis once.

Work out the coordinates of this point of intersection.

.....
.....
.....
.....

Answer (..... ,) (2 marks)

11 (b) Explain why a value for y cannot be found when $x = \frac{3}{2}$

.....
.....
.....
.....

(2 marks)

11 (c) Write down or work out another value of x for which a value for y cannot be found.

.....
.....

Answer (1 mark)

END OF QUESTIONS



ASSESSMENT and
QUALIFICATIONS
ALLIANCE

General Certificate of Secondary Education

Mathematics (Pilot) 9307

Unit 3, Higher Tier, Paper 1

Mark Scheme

Specimen Paper

Mark schemes are prepared by the Principal Examiner and considered, together with the relevant questions, by a panel of subject teachers. This mark scheme includes any amendments made at the standardisation meeting attended by all examiners and is the scheme which was used by them in this examination. The standardisation meeting ensures that the mark scheme covers the candidates' responses to questions and that every examiner understands and applies it in the same correct way. As preparation for the standardisation meeting each examiner analyses a number of candidates' scripts: alternative answers not already covered by the mark scheme are discussed at the meeting and legislated for. If, after this meeting, examiners encounter unusual answers which have not been discussed at the meeting they are required to refer these to the Principal Examiner.

It must be stressed that a mark scheme is a working document, in many cases further developed and expanded on the basis of candidates' reactions to a particular paper. Assumptions about future mark schemes on the basis of one year's document should be avoided; whilst the guiding principles of assessment remain constant, details will change, depending on the content of a particular examination paper.

Further copies of this Mark Scheme are available to download from the AQA Website: www.aqa.org.uk

Copyright © 2008 AQA and its licensors. All rights reserved.

The Assessment and Qualifications Alliance (AQA) is a company limited by guarantee registered in England and Wales 3644723 and registered charity number 1073334.
Registered address AQA, Devas Street, Manchester M15 6EX *Dr Michael Cresswell Director General.*

Glossary for Mark Schemes

GCSE examinations are marked in such a way as to award positive achievement wherever possible. Thus, for GCSE Mathematics papers, marks are awarded under various categories.

- M** Method marks are awarded for a correct method which could lead to a correct answer.
- A** Accuracy marks are awarded when following on from a correct method. It is not necessary to always see the method. This can be implied.
- B** Marks awarded independent of method.
- D** Marks awarded independent of method for correct use of data sheet.
- M dep** A method mark dependent on a previous method mark being awarded.
- B dep** A mark that can only be awarded if a previous independent mark has been awarded.
- ft** Follow through marks. Marks awarded following a mistake in an earlier step.
- SC** Special case. Marks awarded within the scheme for a common misinterpretation which has some mathematical worth.
- oe** Or equivalent. Accept answers that are equivalent.
eg, accept 0.5 as well as $\frac{1}{2}$

Unit 3, Higher, Paper 1

Q	Answer	Mark	Comments
1(a)	$24.5(0) + 12.25 \times 2$	M1	oe
	49	A1	
1(b)(i)	Normal = $24.5 + 12.25 (= 36.75)$	M1	
	(Saving =) £6.75	A1	
1(b)(ii)	Normal = $24.5 + 3 \times 12.25$	M1	
	61.25 and Offer is £1.25 cheaper or Choose offer 2	A1	oe
2(a)	$280 \div 30$ or 9(...)	M1	
	$560 \div 20$ or 28	M1	
	10×28	M1dep	
	280	A1	
2(b)	$5.6 - 1.7 (= 3.9)$	M1	$1.7 \div 3 (= 0.566\dots)$
	$(5.6 - 1.7) \div 3$ or $3.9 \div 3$	M1dep	$5.6 \div 3 - 0.4666\dots$ or $1.8666 - 0.5666$
	1.3	A1	
3(a)	$4x - 4$	M1	
	$7x - 4$	A1	
3(b)	$V + 8y$	M1	
	$\frac{V + 8y}{3}$	A1	
3(c)	y^{10}	M1	
	y^5	A1	

Q	Answer	Mark	Comments
4(a)	$p < 500$	B1	oe
4(b)	$2p$	B1	
4(c)	$2p + p > 1400$	M1	
	$p > 466(\dots)$	A1	
	Two values for p such that $466 < p < 500$	A1	One correct value implies M1A1A0
5(a)	None	B1	
5(b)	Volume	B1	
5(c)	Length	B1	
6	1.5 or $\frac{3}{2}$ or $\frac{2}{3}$ seen	M1	oe
	7×1.5	M1dep	oe
	10.5	A1	
7(a)	Valid explanation	B1	eg, Angle ATD should be 90°
7(b)	110	B1	
7(c)	$180 - 35 - 113$ or 32 seen or $110 - 32$	M1	
	78	A1	
8(a)	$x^2 + 2x - 9x - 18$	B1	Must see all four terms
8(b)	$(x - 2)(x + 2)$	B1	
	$\frac{x - 2}{x - 9}$	B1	Do not ignore fw

Q	Answer	Mark	Comments
9	$(2w^2 + 10w + 20w) \times 2$	M1	Allow 1 error, may use any letter for width or $l/2$ throughout
	$4w^2 + 60w = 504$	M1dep	oe
	$w^2 + 15w - 126 = 0$ or $4w^2 + 60w - 504 = 0$	M1dep	oe
	$(w - 6)(w + 21) = 0$	M1dep	Allow $(w \pm a)(w \pm b)$ where $ab = 126$ oe
	$w = 6$	A1	
10	$42 = \frac{1}{3} \times 20 \times h$ or $84 = \frac{2}{3} \times 20 \times h$ $42 \times 3 = 20h$ or 42×3 or $42 \div 20$	M1	
	$42 \times 3 \div 20$ or 6.3	M1dep	
	12.6	A1	
11(a)	$2x + 7 = 0$	M1	
	$(-\frac{7}{2}, 0)$	A1	
11(b)	$9 - 4x^2 = 0$	B1	or $9 - 4(\frac{3}{2})^2$
	Cannot divide by zero	B1	
11(c)	$-\frac{3}{2}$ or a value of x such that $x > \frac{3}{2}$ or $x < -\frac{3}{2}$	B1	

Surname						Other Names					
Centre Number						Candidate Number					
Candidate Signature											

For Examiner's Use

General Certificate of Secondary Education

MATHEMATICS (PILOT)
Unit 3 Foundation Tier
Paper 2 Calculator

93003/2F

F



Specimen Paper (Curriculum Pathways Pilot 2009)

<p>For this paper you must have:</p> <ul style="list-style-type: none"> • a calculator • mathematical instruments. 	
---	--

For Examiner's Use	
Pages	Mark
3	
4 – 5	
6 – 7	
8 – 9	
10 – 11	
12 – 13	
14 - 15	
16	
TOTAL	
Examiner's Initials	

Time allowed: 1 hour

Instructions

- Use black ink or black ball-point pen. Draw diagrams in pencil.
- Fill in the boxes at the top of this page.
- Answer **all** questions.
- You must answer the questions in the spaces provided. Answers written in margins or on blank pages will not be marked
- Use a calculator where appropriate.
- Do all rough work in this book.
- If your calculator does not have a π button, take the value of π to be 3.14 unless another value is given in the question.

Information

- The maximum mark for this paper is 50.
- The marks for questions are shown in brackets.
- You may ask for more answer paper, graph paper and tracing paper. This must be tagged securely to this answer book.

Advice

- In all calculations, show clearly how you work out your answer.

Formulae Sheet: Foundation Tier

Area of trapezium = $\frac{1}{2}(a+b)h$

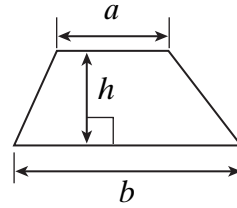

Volume of prism = area of cross-section \times length

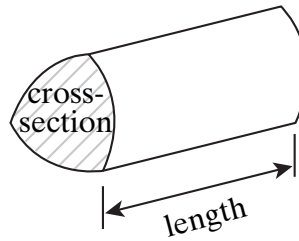

Answer **all** questions in the spaces provided.

- 1 The diagram shows a line AB and a point C drawn on a centimetre grid.

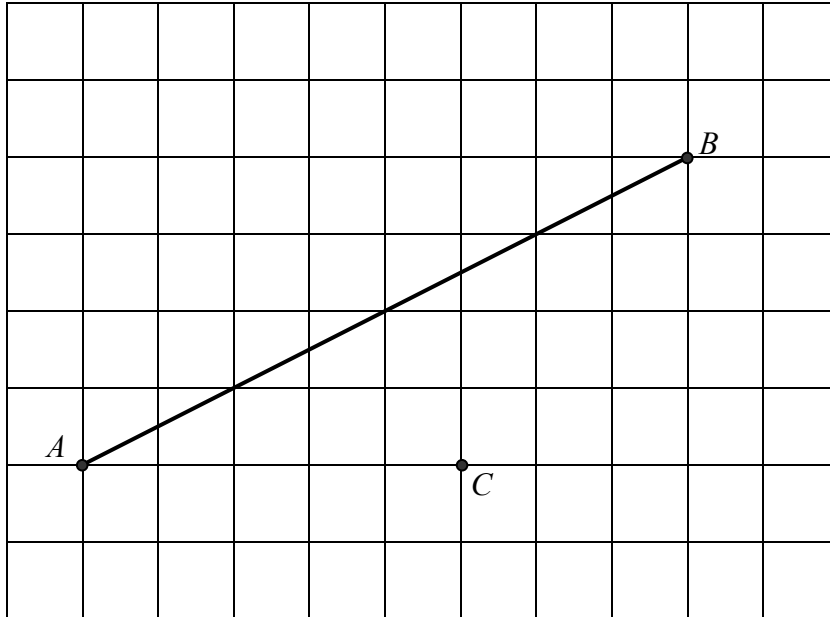

- 1 (a) Measure the length of the line AB in centimetres.

Answer cm (1 mark)

- 1 (b) Mark the midpoint of AB with a cross.
Label it M .

(1 mark)

- 1 (c) Draw a line through C that is parallel to AB .

(1 mark)

- 1 (d) Is ABC an isosceles triangle?
Explain how you know.

.....
.....
.....

(1 mark)

- 2 The shaded shape is drawn on a centimetre grid.

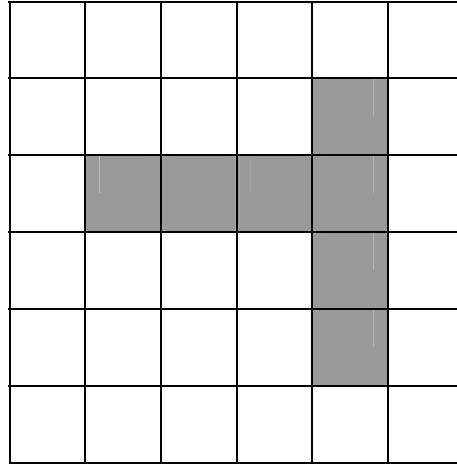

- 2 (a) Work out the area of the shaded shape.

State the units of your answer

.....

Answer (2 marks)

- 2 (b) On the grid draw a square with the same perimeter as the shaded shape.

.....

.....

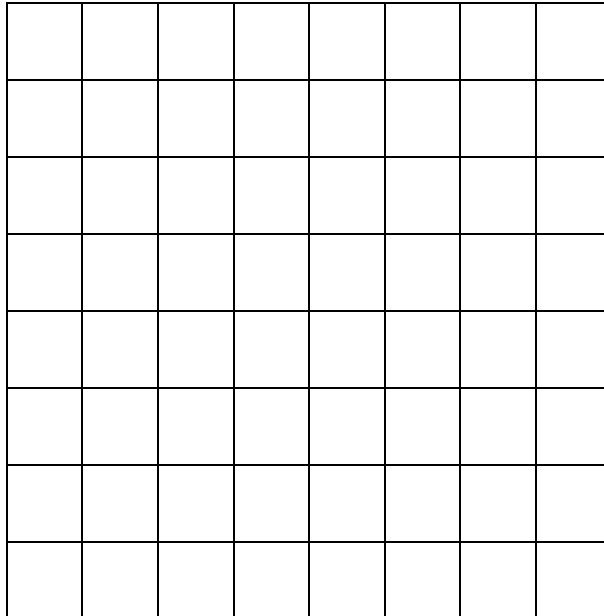

(2 marks)

2 (c) The shaded shape is reflected in the dotted line.

Draw the reflected shape on the grid.

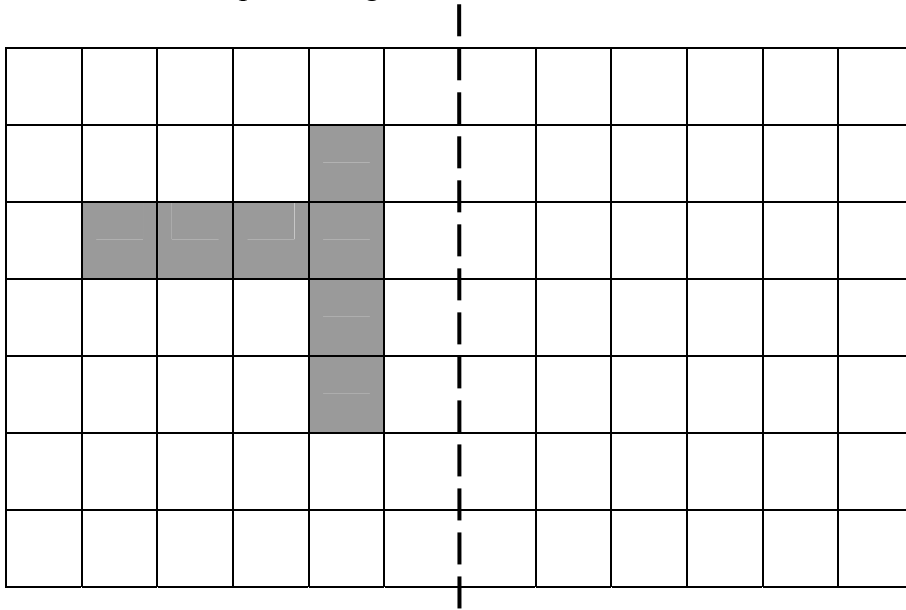

(2 marks)

Turn over for the next question

Turn over ►

3 Here are the first five terms in a sequence of numbers.

7 11 15 19 23 ...

3 (a) What is the next term in the sequence?

.....

Answer (1 mark)

3 (b) Explain how you worked out your answer.

.....

.....

(1 mark)

3 (c) The 100th term in the sequence is 403
What is the 99th term in the sequence?

.....

Answer (1 mark)

- 4 The Centre for Life is a museum.

Centre for Life
Admission charges

Ticket type	Summer April to September	Winter October to March
Adult	£ 8.00	£ 7.65
Child aged 5 to 16	£ 5.85	£ 5.55
Child aged 4 and under	Free	Free
Family ticket 2 adults and 2 children or 1 adult and 3 children	£ 24.20	£ 23.10

- 4 (a) Mr Smith and his 8 year old son visit the Centre for Life in August.

Work out the total admission charge.

.....
.....

Answer £ (2 marks)

- 4 (b) Mr and Mrs Jones and their three children, aged 6, 8 and 11 visit the Centre for Life in January.

Work out the lowest possible admission charge.

.....
.....
.....
.....

Answer £ (2 marks)

- 5 (a) Solve the equation $7x = 28$

.....
 Answer $x =$ (1 mark)

- 5 (b) Solve the equation $x + 9 = 37$

.....
 Answer $x =$ (1 mark)

- 6 (a) Work out angle x .

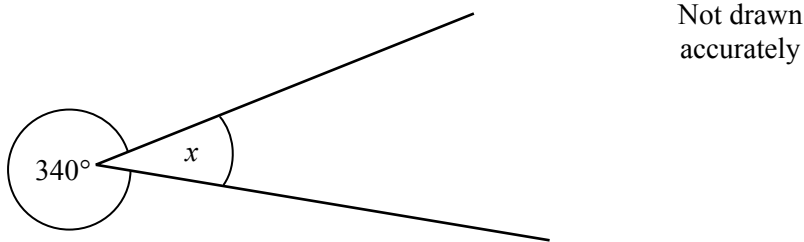

.....
 Answer degrees (1 mark)

- 6 (b) Work out angle y .

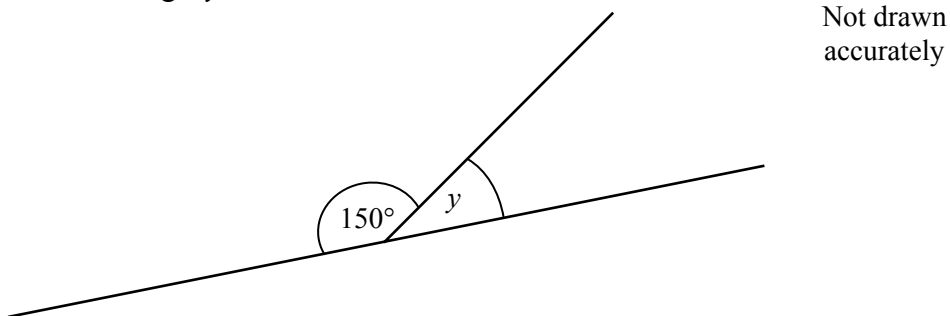

.....
 Answer degrees (1 mark)

- 7 Jane is looking at the cost of different boxes of Breakfast Bix.

Number of biscuits in a box	Cost
12	£0.97
24	£1.78
48	£3.24
72	£3.99

- 7 (a) She buys a box of Breakfast Bix containing 48 biscuits.

Work out the cost of **one** biscuit.

Give your answer in pence to one decimal place.

.....

Answer pence (3 marks)

- 7 (b) Jane compares the cost per biscuit for the different sized boxes.

She says that the cheapest biscuit costs about 2.5 pence less than the most expensive biscuit.

Show that Jane is correct.

.....

Answer (3 marks)

- 8 (a) Complete the table of values of $y = 3x + 1$

x	-2	-1	0	1	2
y	-5		1	4	

.....
.....

(1 mark)

- 8 (b) On the grid below, draw the graph of $y = 3x + 1$ for values of x from -2 to +2

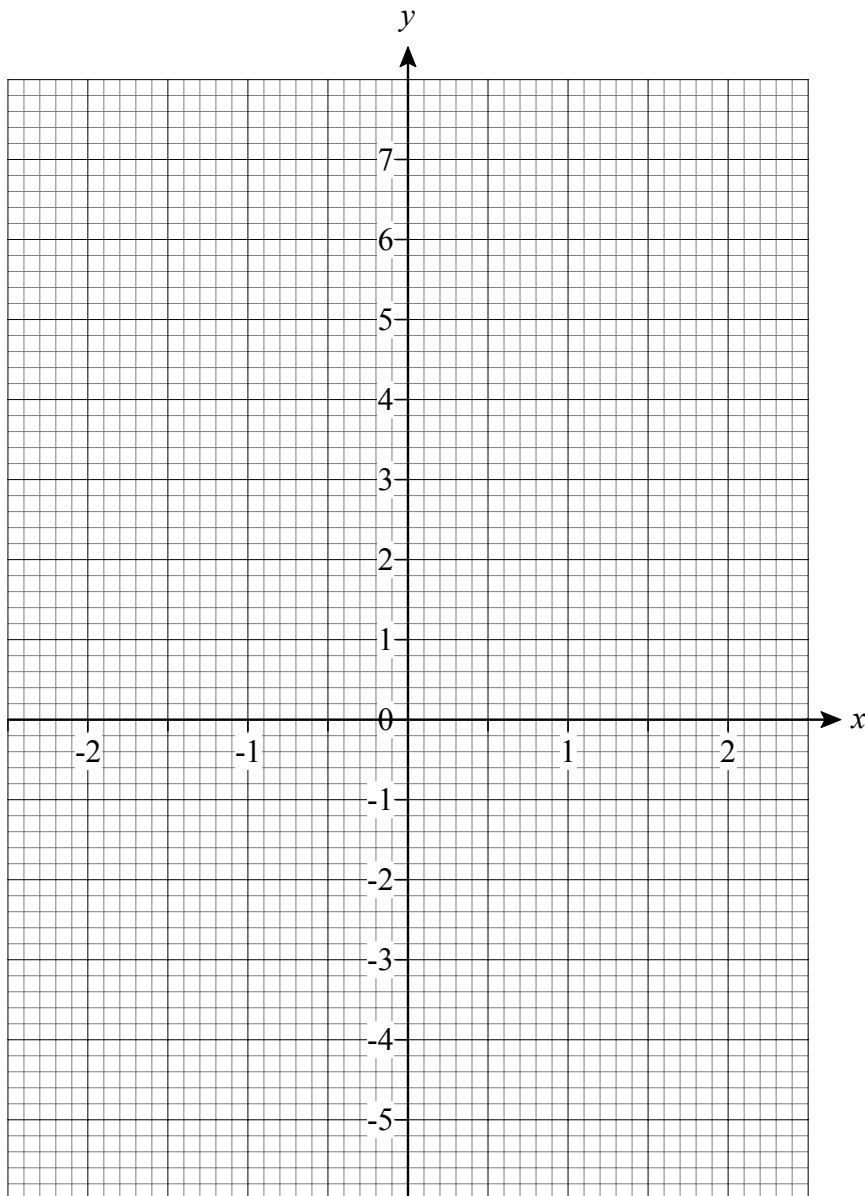

(2 marks)

- 9 The table shows the national minimum wage for people of different ages.

Age	Wage rate (£ per hour)
22 years and over	5.73
18 - 21	4.77
16 - 17	3.53

The average hourly rate for employees must be at least the national minimum wage.

$$\text{Average hourly rate} = \frac{\text{Total amount earned (£)}}{\text{Total time worked (hours)}}$$

- 9 (a) Tom is 19 years old.

Last week he worked 30 hours and was paid £ 144.00.

Show that he is paid **more** than the national minimum wage.

.....

(2 marks)

- 9 (b) Sally is 25 years old and works for 40 hours each week.

This is how the total amount that she earns each week is worked out.

$$\text{Total amount earned} = 40 \times \text{basic hourly rate} + \text{bonus}$$

Sally's basic hourly rate is £ 3.30 per hour.

What is the smallest bonus she can earn so that she is paid the national minimum wage?

.....

Answer £ (3 marks)

Turn over ►

10 Simplify $3a + 4b + 7a - 6b$

.....

.....

Answer (2 marks)

11 Show that quadrilateral $ABCD$ could be a square.

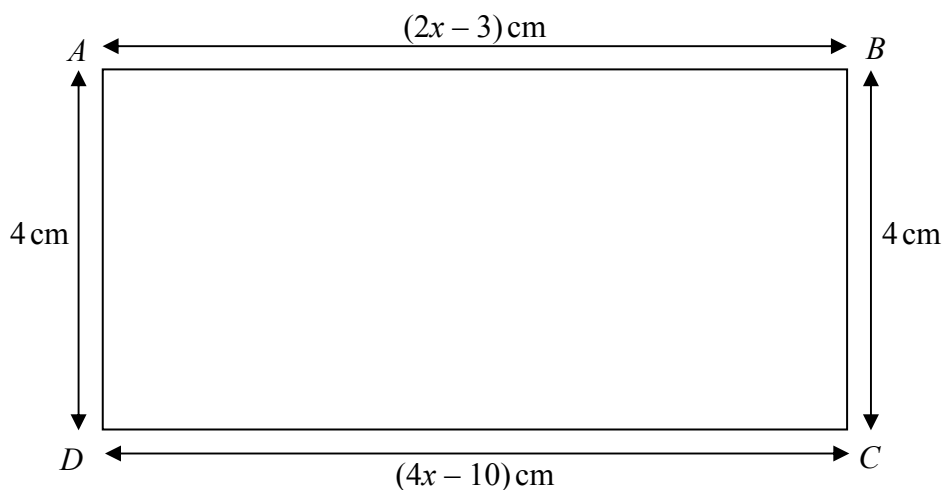

.....

.....

.....

.....

.....

.....

(3 marks)

THIS PAGE IS INTENTIONALLY BLANK

Turn over 

- 12** The total length of all the fish that can live safely in a fish tank can be estimated using this formula

$$T = \frac{9VL}{10000}$$

Where T is the total length of the fish in the tank in centimetres

V is the volume of the tank in cubic centimetres

L depends on the type of filter in the tank

Values of L , for different types of filter are shown

Filter	L
Under-gravel	1.0
Internal filter	1.2
Oversized internal filter	1.4
External filter	1.7
Oversized external filter	2.0

Matthew buys this fish tank.

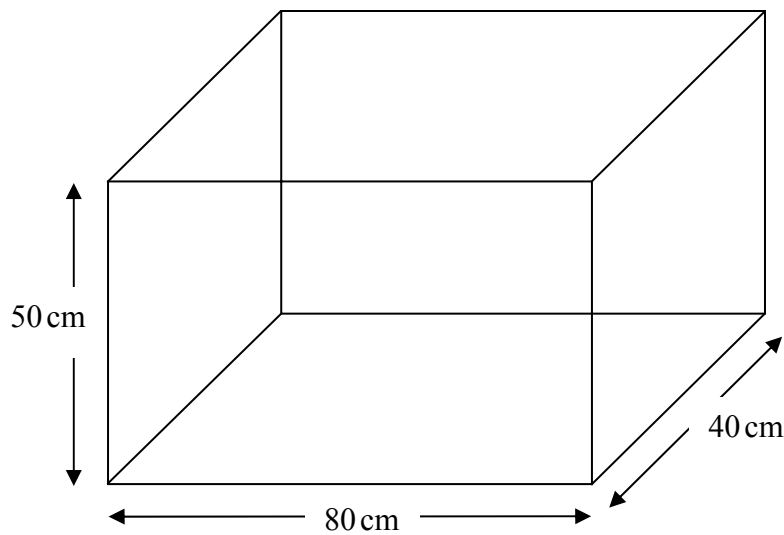

Not drawn
accurately

Matthew has a list of fish that he wants to buy.

He estimates that the total length of these fish is 225 cm.

Matthew needs to make sure that these fish can live safely in the tank.

What type of filter should he buy?

You **must** show your working.

.....

.....

.....

.....

.....

.....

.....

.....

.....

.....

.....

.....

Answer (5 marks)

Turn over ►

5

- 11** Olga lives in the west of Newcastle.
 She plans to drive to the east of Newcastle, a distance of 8 miles.
 The average speed of traffic in Newcastle is 24 miles per hour.



I want to arrive before 1.00 pm
 So the latest I should leave home is 12.45 pm

- 11** (a) Olga starts her journey at 12.45 pm.

Show that she is likely to be late if she drives at the average speed.

.....

(2 marks)

- 11** (a) Marek drives 8 miles to work in London.
 On average his journey takes $28\frac{1}{2}$ minutes.

Work out his average speed in miles per hour.

.....

Answer miles per hour (3 marks)

END OF QUESTIONS



ASSESSMENT and
QUALIFICATIONS
ALLIANCE

General Certificate of Secondary Education

Mathematics (Pilot) 9307

Unit 3, Foundation Tier, Paper 2

Mark Scheme

Specimen Paper

Mark schemes are prepared by the Principal Examiner and considered, together with the relevant questions, by a panel of subject teachers. This mark scheme includes any amendments made at the standardisation meeting attended by all examiners and is the scheme which was used by them in this examination. The standardisation meeting ensures that the mark scheme covers the candidates' responses to questions and that every examiner understands and applies it in the same correct way. As preparation for the standardisation meeting each examiner analyses a number of candidates' scripts: alternative answers not already covered by the mark scheme are discussed at the meeting and legislated for. If, after this meeting, examiners encounter unusual answers which have not been discussed at the meeting they are required to refer these to the Principal Examiner.

It must be stressed that a mark scheme is a working document, in many cases further developed and expanded on the basis of candidates' reactions to a particular paper. Assumptions about future mark schemes on the basis of one year's document should be avoided; whilst the guiding principles of assessment remain constant, details will change, depending on the content of a particular examination paper.

Further copies of this Mark Scheme are available to download from the AQA Website: www.aqa.org.uk

Copyright © 2008 AQA and its licensors. All rights reserved.

The Assessment and Qualifications Alliance (AQA) is a company limited by guarantee registered in England and Wales 3644723 and registered charity number 1073334.
Registered address AQA, Devas Street, Manchester M15 6EX *Dr Michael Cresswell Director General.*

Glossary for Mark Schemes

GCSE examinations are marked in such a way as to award positive achievement wherever possible. Thus, for GCSE Mathematics papers, marks are awarded under various categories.

- M** Method marks are awarded for a correct method which could lead to a correct answer.
- A** Accuracy marks are awarded when following on from a correct method. It is not necessary to always see the method. This can be implied.
- B** Marks awarded independent of method.
- D** Marks awarded independent of method for correct use of data sheet.
- M dep** A method mark dependent on a previous method mark being awarded.
- B dep** A mark that can only be awarded if a previous independent mark has been awarded.
- ft** Follow through marks. Marks awarded following a mistake in an earlier step.
- SC** Special case. Marks awarded within the scheme for a common misinterpretation which has some mathematical worth.
- oe** Or equivalent. Accept answers that are equivalent.
eg, accept 0.5 as well as $\frac{1}{2}$

Unit 3, Foundation Tier, Paper 2

Q	Answer	Mark	Comments
1(a)	8.8 to 9.1	B1	
1(b)	Midpoint marked	B1	
1(c)	Parallel line drawn	B1	
1(d)	Yes and $AC = CB (= 5 \text{ cm})$	B1	or Yes and CM is a line of symmetry oe
2(a)	7	B1	oe
	cm^2	B1	oe
2(b)	4 by 4 square drawn	B2	B1 Perimeter 16 seen or rectangle with perimeter 16 or Any square drawn
2(c)	Whole shape reflected in correct line	B2	B1 Whole shape reflected in wrong line
3(a)	27	B1	
3(b)	Term-to-term rule +4	B1	oe
3(c)	399	B1	
4(a)	$8(.00) + 5.85$	M1	
	(£) 13.85	A1	SC1 (£) 13.20
4(b)	(£) 28.65	B2	B1 $23.1(0) + 5.55$ or £30.75 or £29.95 or £30.05
5(a)	4	B1	
5(b)	28	B1	
6(a)	20	B1	
6(b)	30	B1	

Q	Answer	Mark	Comments	
7(a)	$3.24 \div 48$	M1	or $324 \div 48$	
	0.0675	A1	or 6.75	
	6.8	A1		
7(b)	$0.97 \div 12$ or $1.78 \div 24$ or $3.99 \div 72$	M1	or $97 \div 12$ or $178 \div 24$ or $399 \div 72$	
	(Their 8.08 ...) – (their 5.54 ...)	M1	or (Their 0.0808 ...) – (their 0.0554 ...)	
	2.54 ...	A1		
8(a)	$-1 \rightarrow -2$ and $2 \rightarrow 7$	B1		
8(b)	Straight line passing through $(-2, -5)$, $(-1, -2)$, $(0, 1)$, $(1, 4)$ and $(2, 7)$	B2	B1 Their points plotted correctly or Line through three correct points	
9(a)	$144.(00) \div 30$	M1	30×4.77	
	4.80 (> 4.77)	A1	143.1(0) ($> 144..(00)$)	
9(b)	40×5.73 or 40×3.3	M1	or (£)229.2(0) or 132	
	(Their) 229.2 – (their) 132	M1		
	(£)97.20	A1		
10	$10a - 2b$ or $2(5a - b)$	B2	B1 $10a$ or $-2b$	
11	$2x - 3 = 4$	$4x - 10 = 4$	M1	or $2x - 3 = 4x - 10$
	$x = 3.5$		A1	
	$4 \times 3.5 - 10$	$2 \times 3.5 - 3$	B1	$2 \times 3.5 - 3$ and $4 \times 3.5 - 10$

Q	Answer	Mark	Comments	
12	$50 \times 80 \times 40$	M1		
	160 000	A1		
	$9 \times (\text{their } 160\,000)L \div 10\,000$	M1	or $(225 =) 144L$	
	$225 \div (\text{their } 144)$	M1	or 1.56... or Trying values of L using (their) $144L$ to find total length ≥ 225	
	1.56... and External	A1	Allow oversized external Must see method for last M2A1	
13(a)	$8 \div 24 \times 60$ or 20	M1	or 4×8 oe	
	Needs to leave at or before 12.40	A1	or 5 minutes late or Average speed would need to be 32 mph oe	
13(b)	$28.5 \div 60$	M1	or 0.475	or $\frac{20}{28.5}$
	$8 \div (\text{their } 0.475)$	M1	oe	$(\text{Their } 0.70 \dots) \times 24$
	16.8(4...)	A1		

Surname						Other Names					
Centre Number						Candidate Number					
Candidate Signature											

For Examiner's Use

General Certificate of Secondary Education

MATHEMATICS (PILOT)
Unit 3 Higher Tier
Paper 2 Calculator

93003/2H

H



Specimen Paper (Curriculum Pathways Pilot 2009)

<p>For this paper you must have:</p> <ul style="list-style-type: none"> • a calculator • mathematical instruments. 	
---	--

For Examiner's Use	
Pages	Mark
3	
4 – 5	
6 – 7	
8 – 9	
10 – 11	
12 - 13	
TOTAL	
Examiner's Initials	

Time allowed: 1 hour

Instructions

- Use black ink or black ball-point pen. Draw diagrams in pencil.
- Fill in the boxes at the top of this page.
- Answer **all** questions.
- You must answer the questions in the spaces provided. Answers written in margins or on blank pages will not be marked
- Use a calculator where appropriate.
- Do all rough work in this book.
- If your calculator does not have a π button, take the value of π to be 3.14 unless another value is given in the question.

Information

- The maximum mark for this paper is 50.
- The marks for questions are shown in brackets.
- You may ask for more answer paper, graph paper and tracing paper. This must be tagged securely to this answer book.

Advice

- In all calculations, show clearly how you work out your answer.

Formulae Sheet: Higher Tier

Area of trapezium = $\frac{1}{2}(a+b)h$

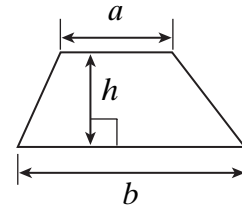

Volume of prism = area of cross-section \times length

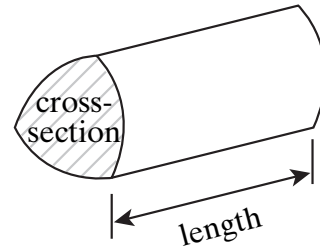

Volume of sphere = $\frac{4}{3} \pi r^3$

Surface area of sphere = $4 \pi r^2$

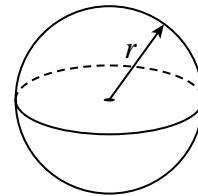

Volume of cone = $\frac{1}{3} \pi r^2 h$

Curved surface area of cone = $\pi r l$

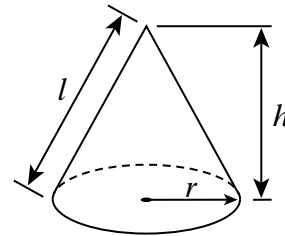

In any triangle ABC

Area of triangle = $\frac{1}{2} ab \sin C$

Sine rule $\frac{a}{\sin A} = \frac{b}{\sin B} = \frac{c}{\sin C}$

Cosine rule $a^2 = b^2 + c^2 - 2bc \cos A$

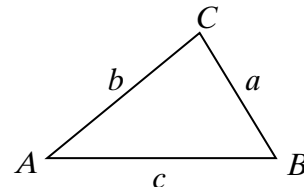

The Quadratic Equation

The solutions of $ax^2 + bx + c = 0$, where $a \neq 0$, are given by

$$x = \frac{-b \pm \sqrt{(b^2 - 4ac)}}{2a}$$

Answer **all** questions in the spaces provided.

1 (a) Expand $3(x - 4)$

.....

Answer (1 mark)

1 (b) Factorise $8x - 12$

.....

Answer (1 mark)

1 (c) Expand $x^2(x^3 + 2)$

.....

Answer (1 mark)

2 Show that quadrilateral $ABCD$ could be a square.

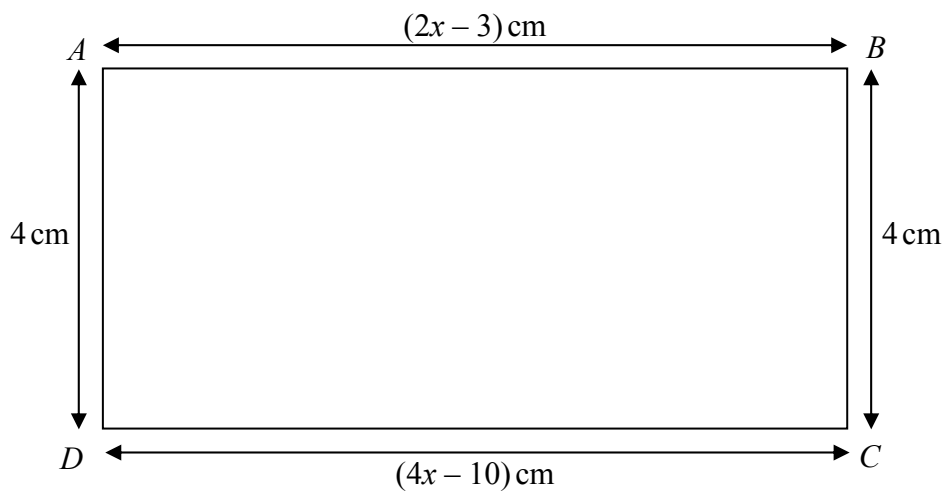

Not drawn
accurately

.....

.....

.....

.....

.....

.....

.....

(3 marks)

- 3 This diagram has a rotational symmetry of order 2.

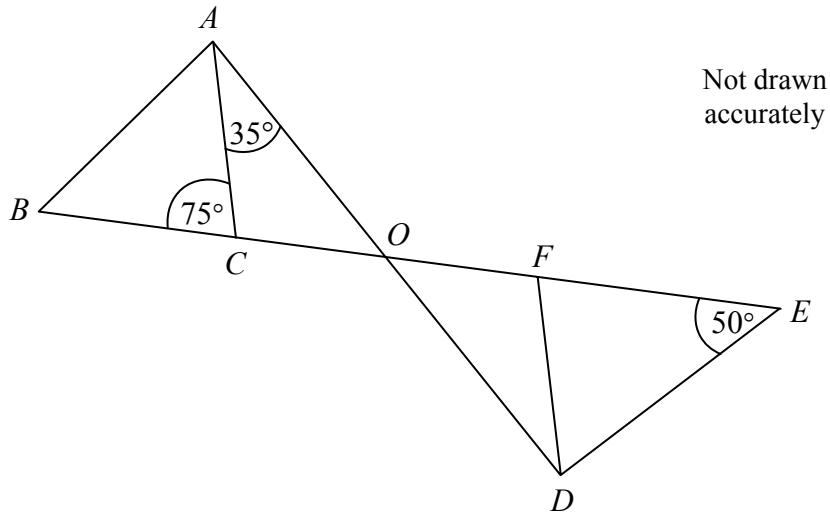

- 3 (a) Show clearly that triangle OAB has a right angle at A .

.....

.....

.....

.....

..... (3 marks)

- 3 (b) How do you know that the lines AC and FD are parallel?

.....

.....

..... (1 mark)

- 4 The table shows the national minimum wage for people of different ages.

Age	Wage rate (£ per hour)
22 years and over	5.73
18 - 21	4.77
16 - 17	3.53

The average hourly rate for employees must be at least the national minimum wage

$$\text{Average hourly rate} = \frac{\text{Total amount earned (£)}}{\text{Total time worked (hours)}}$$

Sally is 25 years old and works 40 hours each week.

This is how the total amount that she earns each week is worked out.

$$\text{Total amount earned} = 40 \times \text{basic hourly rate} + \text{bonus}$$

Sally's basic hourly rate is £ 3.30 per hour.

What is the smallest bonus she can earn so that she is paid the national minimum wage?

.....

.....

.....

.....

.....

.....

.....

Answer £ (3 marks)

Turn over ►

- 5 The total length of all the fish that can live safely in a fish tank can be estimated using this formula

$$T = \frac{9VL}{10000}$$

Where T is the total length of the fish in the tank in centimetres

V is the volume of the tank in cubic centimetres

L depends on the type of filter in the tank

Values of L , for different types of filters are shown.

Filter	L
Under-gravel	1.0
Internal filter	1.2
Oversized internal filter	1.4
External filter	1.7
Oversized external filter	2.0

Matthew buys this fish tank.

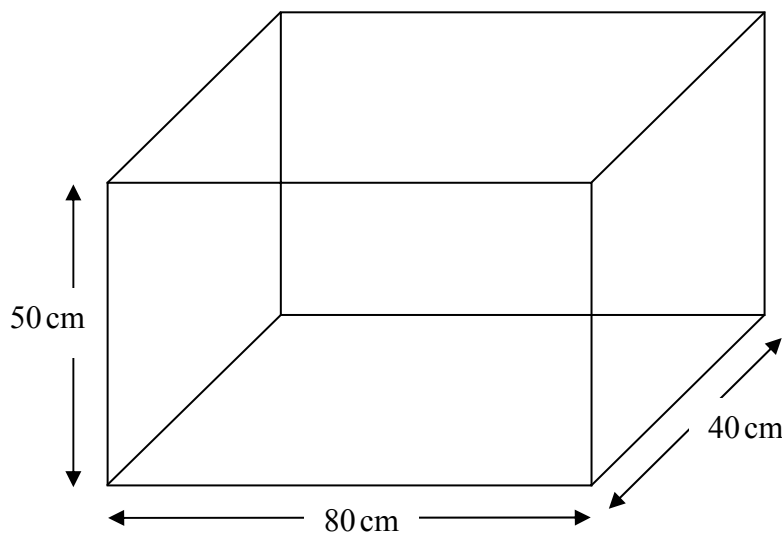

Not drawn
accurately

Matthew has a list of fish that he wants to buy.
He estimates that the total length of these fish is 225 cm.
Matthew needs to make sure that these fish can live safely in the tank.

What type of filter should he buy?

You **must** show your working.

.....

.....

.....

.....

.....

.....

.....

.....

.....

.....

.....

Answer (5 marks)

Turn over ►

5

6 In the diagram AB is parallel to CD.

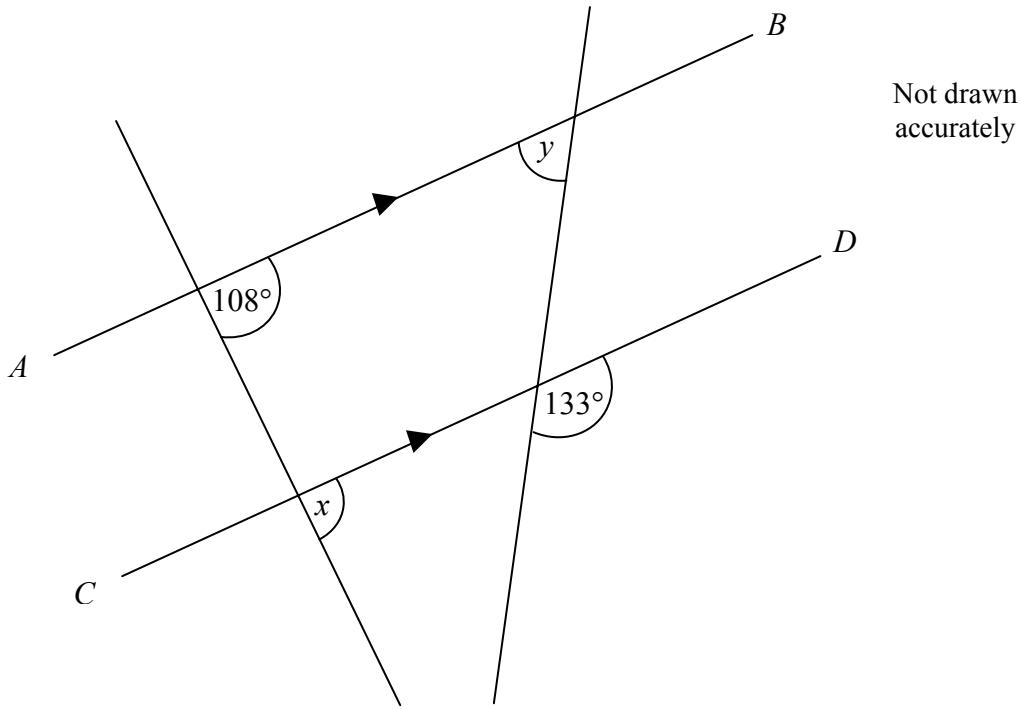

6 (a) Write down the value of x .

Answer degrees (1 mark)

6 (b) Work out the value of y .

.....

Answer degrees (2 marks)

7 Marek drives 8 miles to work in London.

On average his journey takes $28\frac{1}{2}$ minutes.

Work out his average speed in miles per hour.

.....

.....

.....

.....

.....

.....

Answer miles per hour (3 marks)

- 8 Solve the simultaneous equations $5x + 6y = 28$
 $x + 3y = 2$

You **must** show your working.

Do **not** use trial and improvement.

.....

.....

.....

.....

.....

.....

.....

.....

.....

Answers $x =$, $y =$ (3 marks)

- 9 The diagram shows a letter **Z** drawn inside a rectangle.

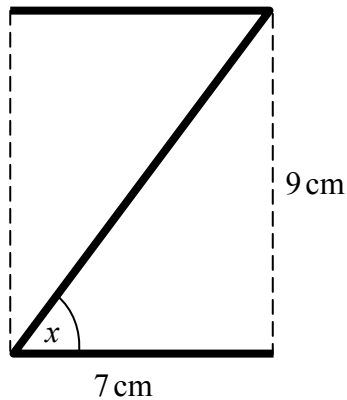

Not drawn
accurately

Work out the size of the angle marked x .

.....

.....

.....

.....

.....

Answer degrees (3 marks)

Turn over ►

10 The diagram shows a sketch of the line $2y = x - 4$

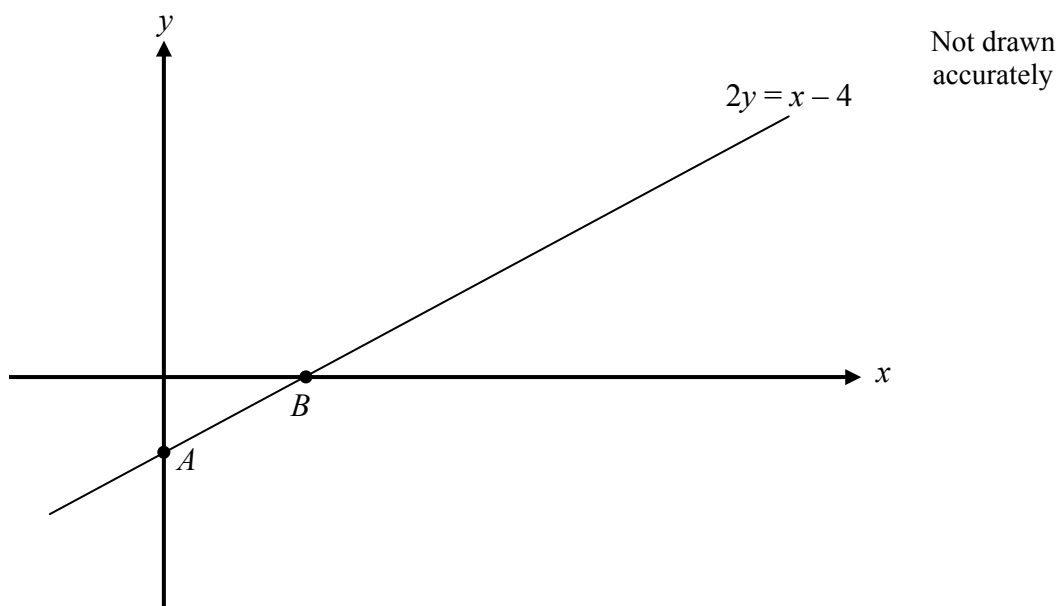

10 (a) Work out the coordinates of the points A and B .

.....

Answers A (.....,) .

B (.....,) (2 marks)

10 (b) Work out the gradient of the line $2y = x - 4$

.....

Answer (2 marks)

11 A company sells circular metal badges of different sizes.

The price of each badge is proportional to the square of the radius of the badge.

The price of a small badge of radius 1.2 cm is 36 pence.

What is the price of a large badge of radius 3 cm?

.....

.....

.....

.....

.....

.....

.....

.....

Answer £ (3 marks)

12 $ABCD$ is a quadrilateral.

$AB = 4.6 \text{ cm}$

$BC = 6.9 \text{ cm}$

$AD = 3.8 \text{ cm}$

Angle $ABC = 90^\circ$

Angle $CAD = 48^\circ$

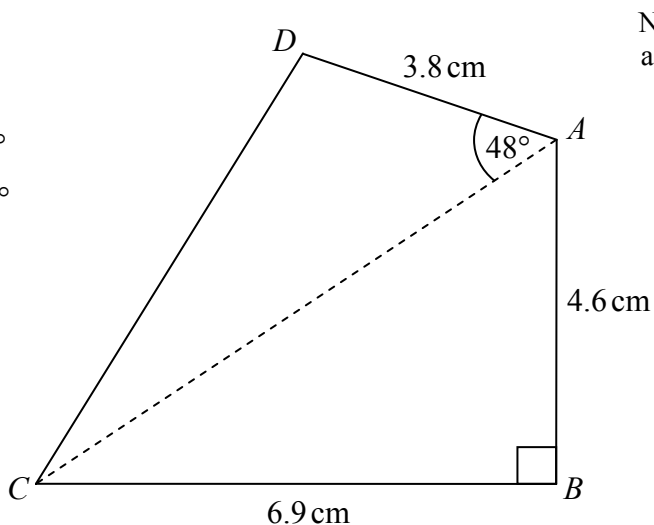

Work out the perimeter of the quadrilateral.

Give your answer to an appropriate degree of accuracy.

.....

.....

.....

.....

.....

.....

.....

.....

.....

.....

Answer cm (5 marks)

- 13** The diagram shows the circle $x^2 + y^2 = 20$ and the line $y = x + 4$.
The line and the circle intersect at the points A and B .

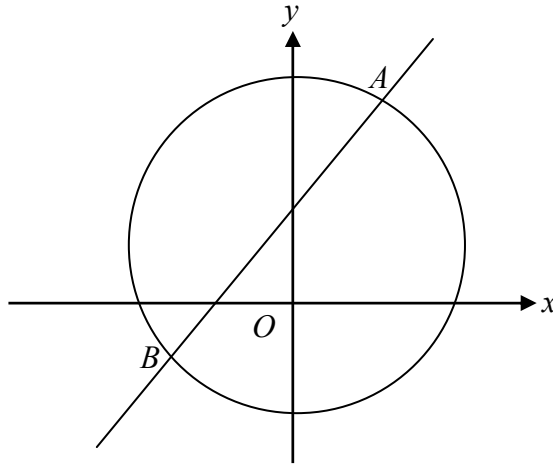

Not drawn accurately

- 13 (a)** Show that the coordinates of A and B satisfy the equation $x^2 + 4x - 2 = 0$

.....

.....

.....

.....

.....

(3 marks)

- 13 (b)** Find the coordinates of A and B .
Give your answers to 2 decimal places.

.....

.....

.....

.....

.....

.....

.....

.....

Answer A (.....,) .

B (.....,) (4 marks)

END OF QUESTIONS

Turn over ►

There are no questions printed on this page

**DO NOT WRITE ON THIS PAGE
ANSWER IN THE SPACES PROVIDED**



ASSESSMENT and
QUALIFICATIONS
ALLIANCE

General Certificate of Secondary Education

Mathematics (Pilot) 9307

Unit 3, Higher Tier, Paper 2

Mark Scheme

Specimen Paper

Mark schemes are prepared by the Principal Examiner and considered, together with the relevant questions, by a panel of subject teachers. This mark scheme includes any amendments made at the standardisation meeting attended by all examiners and is the scheme which was used by them in this examination. The standardisation meeting ensures that the mark scheme covers the candidates' responses to questions and that every examiner understands and applies it in the same correct way. As preparation for the standardisation meeting each examiner analyses a number of candidates' scripts: alternative answers not already covered by the mark scheme are discussed at the meeting and legislated for. If, after this meeting, examiners encounter unusual answers which have not been discussed at the meeting they are required to refer these to the Principal Examiner.

It must be stressed that a mark scheme is a working document, in many cases further developed and expanded on the basis of candidates' reactions to a particular paper. Assumptions about future mark schemes on the basis of one year's document should be avoided; whilst the guiding principles of assessment remain constant, details will change, depending on the content of a particular examination paper.

Further copies of this Mark Scheme are available to download from the AQA Website: www.aqa.org.uk

Copyright © 2008 AQA and its licensors. All rights reserved.

The Assessment and Qualifications Alliance (AQA) is a company limited by guarantee registered in England and Wales 3644723 and registered charity number 1073334.
Registered address AQA, Devas Street, Manchester M15 6EX *Dr Michael Cresswell Director General.*

Glossary for Mark Schemes

GCSE examinations are marked in such a way as to award positive achievement wherever possible. Thus, for GCSE Mathematics papers, marks are awarded under various categories.

- M** Method marks are awarded for a correct method which could lead to a correct answer.
- A** Accuracy marks are awarded when following on from a correct method. It is not necessary to always see the method. This can be implied.
- B** Marks awarded independent of method.
- D** Marks awarded independent of method for correct use of data sheet.
- M dep** A method mark dependent on a previous method mark being awarded.
- B dep** A mark that can only be awarded if a previous independent mark has been awarded.
- ft** Follow through marks. Marks awarded following a mistake in an earlier step.
- SC** Special case. Marks awarded within the scheme for a common misinterpretation which has some mathematical worth.
- oe** Or equivalent. Accept answers that are equivalent.
eg, accept 0.5 as well as $\frac{1}{2}$

Unit 3, Higher Tier, Paper 2

Q	Answer	Mark	Comments	
1(a)	$3x - 12$	B1		
1(b)	$4(2x - 3)$	B1		
1(c)	$x^5 + 2x^2$	B2	B1 x^5 or $2x^2$	
2	$2x - 3 = 4$	$4x - 10 = 4$	M1	or $2x - 3 = 4x - 10$
	$x = 3.5$		A1	
	$4 \times 3.5 - 10$	$2 \times 3.5 - 3$	B1	$2 \times 3.5 - 3$ and $4 \times 3.5 - 10$
3(a)	$\angle ABC = 50^\circ$		B1	
	$\angle BAC = 180 - (50 + 75)$		B1	or $\angle BAC = 55^\circ$
	$55 + 35$		B1	
3(b)	eg, $\angle OAC = \angle ODF$ and alternate Because of rotational symmetry		B1	
4	40×5.73 or 40×3.3		M1	or (£)229.2(0) or 132
	(Their) 229.2 - (their) 132		M1	
	(£)97.20		A1	
5	$50 \times 80 \times 40$		M1	
	160 000		A1	
	$9 \times (\text{their } 160\,000)L \div 10\,000$		M1	or $(225 =) 144L$
	$225 \div (\text{their } 144)$		M1	or 1.56... or Trying values of L using (their) 144l to find total length ≥ 225
	1.56... and External		A1	Allow oversized external Must see method for last M2A1

Q	Answer	Mark	Comments
6(a)	108	B1	
6(b)	180 – 133	M1	
	47	A1	
7	28.5 ÷ 60	M1	or 0.475
	8 ÷ (their 0.475)	M1	
	16.8(4...)	A1	
8	$5x + 6y = 28$ $5x + 6y = 28$ $2x + 6y = 4$ $5x + 15y = 10$	M1	Allow error in one term
	$3x = 24$ $-9y = 18$	M1	Correct elimination from their equations
	$x = 8$ and $y = -2$	A1	SC1 Correct answers with no working or using T&I
9	$\tan x = \frac{9}{7}$	M1	
	Invtan (1.28...)	M1dep	
	52.1(25 ...)	A1	
10(a)	$A \rightarrow (0, -2)$	B1	
	$B \rightarrow (4, 0)$	B1	
10(b)	$y = \frac{1}{2}x - 2$ or $\frac{2}{4}$	M1	
	$\frac{1}{2}$	A1	oe
11	$(3 \div 1.2)^2$ or 6.25	M1	$y \propto x^2$ or $y = kx^2$ or $36 = k \times 1.2^2$
	6.25×36 or 225	M1	$k = 36 \div 1.2^2$ or 25
	(£)2.25	A1	

Q	Answer	Mark	Comments
12	$4.6^2 + 6.9^2$	M1	
	$\sqrt{(\text{their } 68.77)}$	M1dep	or 8.29...
	$\sqrt{(3.8^2 + (\text{their } 68.77) - 2 \times 3.8 \times (\text{their } 8.29 \dots) \times \cos 48)}$	M1	or $\sqrt{20.11 \dots}$ or 4.484...
	$6.9 + 4.6 + (\text{their } 4.484 \dots) + 3.8$	M1dep	or 19.784...
	19.8	A1	
13	$(x^2 +)x^2 + 4x + 4x + 16 (= 20)$	M1	For expansion (4 terms with 3 terms correct)
	$x^2 + (\text{their})(x + 4)^2 = 20$	M1	For substitution (independent of expansion mark)
	Simplifying to $2x^2 + 8x - 4 = 0$ or $x^2 + 4x = 2$	A1	Clearly shown
	$\frac{-(-4) \pm \sqrt{\{4^2 - 4 \times 1 \times (-2)\}}}{2}$	M1	Allow one error in substituting into correct formula
	0.45 and -4.45	A1	
	(Their) 0.45 + 4 or (their) -4.45 + 4	M1	
	(0.45, 4.45) and (-4.45, -0.45)	A1ft	

