

Surname		Other Names	
Centre Number		Candidate Number	
Candidate Signature			

For Examiner's Use

General Certificate of Secondary Education
June 2008

PHYSICS
Unit Physics P3

Foundation Tier

PHY3F
F



Wednesday 11 June 2008 1.30 pm to 2.15 pm

<p>For this paper you must have:</p> <ul style="list-style-type: none"> a ruler. <p>You may use a calculator.</p>

Time allowed: 45 minutes

Instructions

- Use black ink or black ball-point pen.
- Fill in the boxes at the top of this page.
- Answer **all** questions.
- Answer the questions in the spaces provided. Answers written in margins or on blank pages will not be marked.
- Do all rough work in this book. Cross through any work you do not want to be marked.

Information

- The maximum mark for this paper is 45.
- The marks for questions are shown in brackets.
- You are expected to use a calculator where appropriate.
- You are reminded of the need for good English and clear presentation in your answers.

Advice

- In all calculations, show clearly how you work out your answer.

For Examiner's Use			
Question	Mark	Question	Mark
1		6	
2		7	
3			
4			
5			
Total (Column 1) →			
Total (Column 2) →			
TOTAL			
Examiner's Initials			



Answer **all** questions in the spaces provided.

- 1 (a) The diagram shows a lampshade hanging from the ceiling. Draw an **X** on the diagram so that the centre of the **X** marks the centre of the mass of the lampshade.

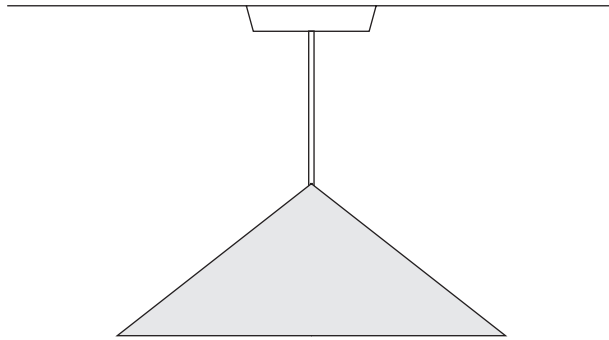

(1 mark)

- 1 (b) Complete the sentence using the correct word or phrase from the box.

above below to the left of to the right of

A suspended object will come to rest with its centre of mass directly
..... the point of suspension.

(1 mark)



- 1 (c) The diagrams show equipment that a student uses to find the centre of mass of a thin sheet of card.

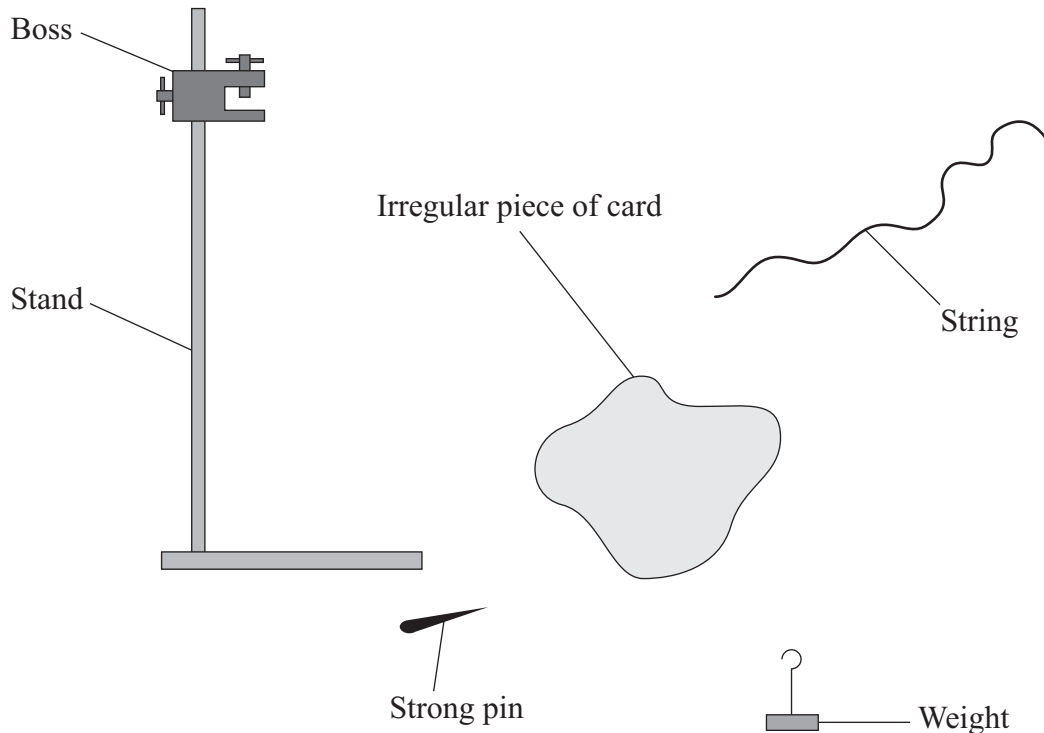

Arrange these sentences in the correct order to describe how the student can find the centre of mass of the card.

The sequence starts with sentence **D** and finishes with sentence **E**.

- A A line is drawn on the card marking the position of the string.
- B The pin is put through one of the holes in the card and held in the boss.
- C This is repeated using the other hole.
- D Two holes are made in the card with each hole near to the edge of the card.
- E The centre of mass is where the lines cross on the card.
- F The weight is tied to the string and then the string is hung from the pin.

D					E
----------	--	--	--	--	----------

(3 marks)



2 The diagram shows the design for a remotely controlled door bolt.

When the correct numbers are entered into the keypad the transformer switches on. Then the door can be opened.

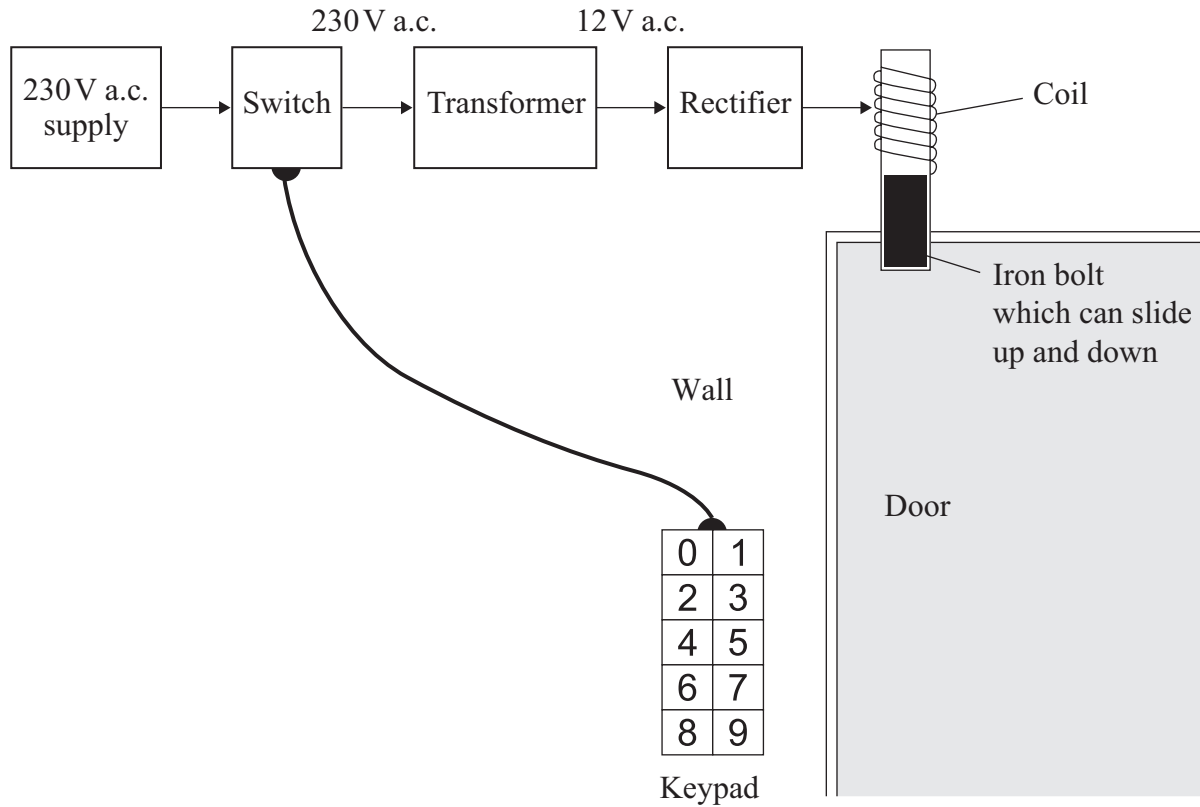

2 (a) What kind of transformer is shown in the diagram?

.....
(1 mark)

2 (b) What does the abbreviation a.c. stand for?

.....
(1 mark)



2 (c) Complete the sentences using the correct words from the box.

attracts	downwards	magnet	reflects	repels
sideways	switch	transformer	upwards	

- (i) When a current flows in the coil, the coil becomes a
- (ii) The coil the iron bolt which moves
(3 marks)

5

Turn over for the next question

Turn over ►



- 3 (a) A student uses a microphone to send different sounds to an oscilloscope. The diagrams show five traces, **A**, **B**, **C**, **D** and **E**, on the oscilloscope. All the traces are drawn to the same scale.

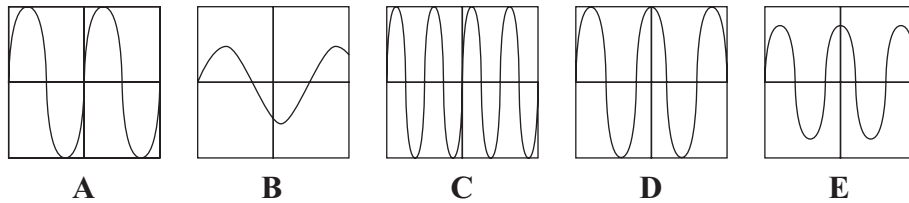

- 3 (a) (i) Which **three** diagrams show traces with the same amplitude?

Diagrams, and (1 mark)

- 3 (a) (ii) Which **two** diagrams show traces with the same frequency?

Diagrams and (1 mark)

- 3 (b) The diagram shows the sound frequencies which some living things can hear.

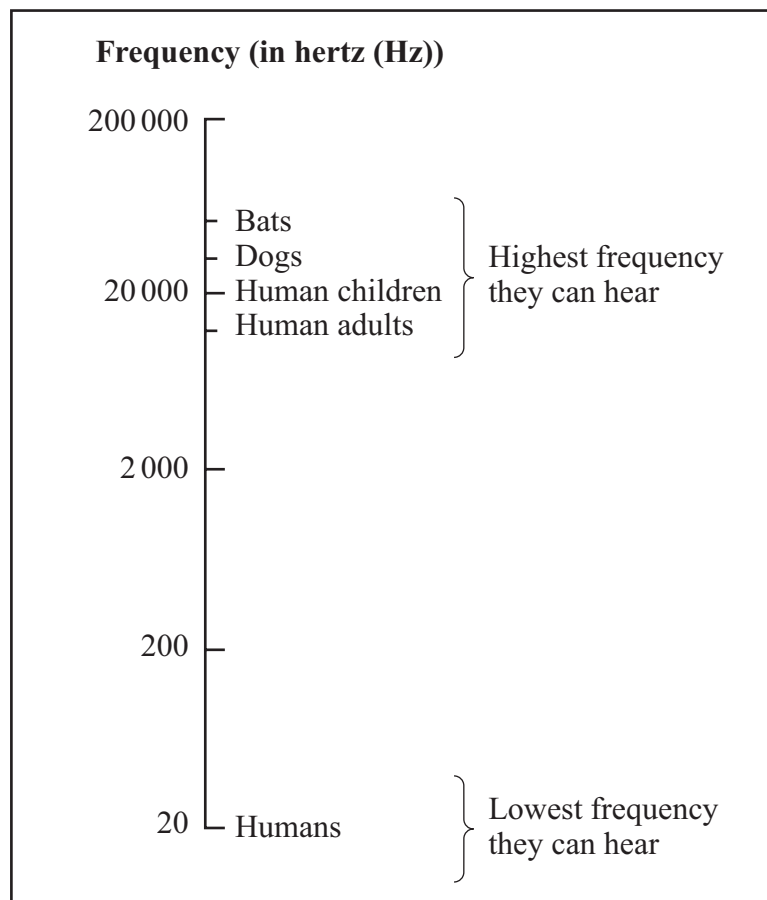

- 3 (b) (i) What is the widest range of frequencies that a human child can hear?

.....
(1 mark)

- 3 (b) (ii) Why can some dog whistles be heard by dogs but not by humans?

.....
.....
(1 mark)

- 3 (c) An ultrasound scan can be used to make a picture of a baby in its mother's womb. An ultrasound transmitter and detector are placed above the mother's womb. Ultrasound goes into the body of the mother and into the body of the baby.

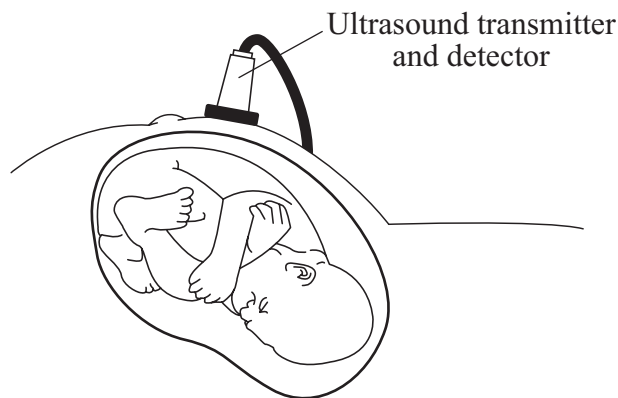

Use the correct words from the box to complete the sentences.

detector reflection refraction sound substance transmitter

- 3 (c) (i) When the ultrasound crosses from one to another, some ultrasound becomes an echo caused by

- 3 (c) (ii) This information is collected by the ultrasound and made into a picture on a screen.

(3 marks)

7

Turn over ►



- 4 (a) Complete the **two** spaces in the sentence.

Stars form when enough and gas from are
pulled together by gravitational attraction. (2 marks)

- 4 (b) How are stars able to give out energy for millions of years?

Put a tick (✓) in the box next to the answer.

By atoms joining together

By atoms splitting apart

By burning gases

(1 mark)

- 4 (c) There are many billions of stars in our galaxy. Our Sun is one of these stars. What is the name of our galaxy?

..... (1 mark)

- 4 (d)

Why was the Universe created?

We cannot expect scientists to answer this question. What is the reason for this?

Put a tick (✓) in the box next to the reason.

It will take too long to collect the scientific evidence.

The answer depends on beliefs and opinions, not scientific evidence.

There is not enough scientific evidence.

(1 mark)

5



5 A girl and her father visit a children's playground.

5 (a) The diagram shows the girl holding on to a roundabout which is turning.

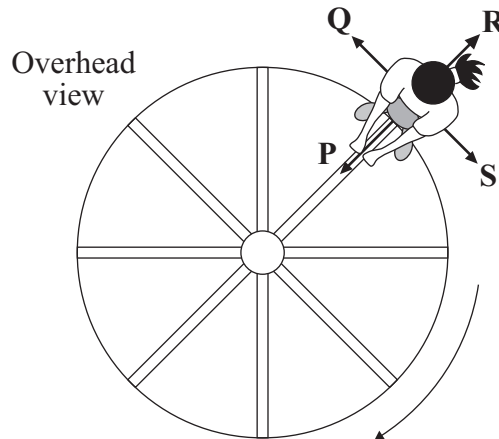

A centripetal force must act because the girl moves in a circular path.

5 (a) (i) In which direction, **P**, **Q**, **R** or **S**, does the centripetal force act?

Direction (1 mark)

5 (a) (ii) What provides this centripetal force?

.....

 (1 mark)

5 (a) (iii) Her father pushes the roundabout so that it turns faster. The girl continues to stand on the same part of the roundabout.

Complete the following sentence by drawing a ring around the correct line in the box.

The centripetal force on the girl

decreases

does not change

increases

(1 mark)

Question 5 continues on the next page

Turn over ►



5 (b) The diagram shows the girl and her father on a see-saw.

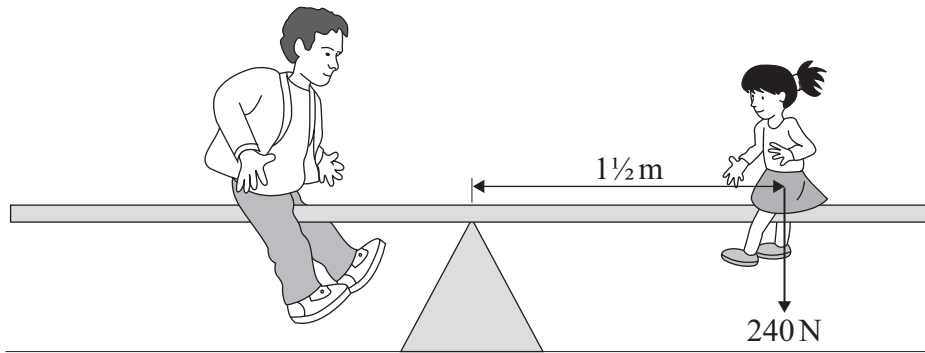

5 (b) (i) Use the equation in the box to calculate the moment of the girl.

$\text{moment} = \text{force} \times \text{perpendicular distance from the line of action of the force to the axis of rotation}$
--

Show clearly how you work out your answer.

.....

Moment of the girl = Nm
 (2 marks)

5 (b) (ii) What must her father do to increase his moment?

.....

(1 mark)



5 (c) The diagram shows part of a level road that they take when they drive home. They drive at a steady speed.

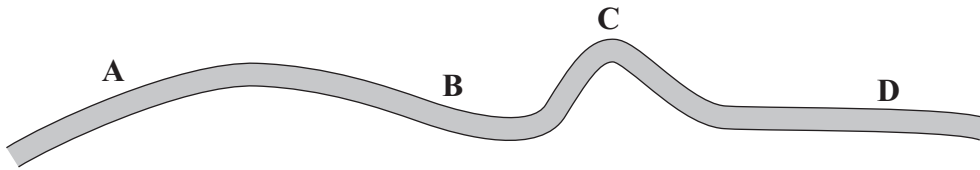

5 (c) (i) At which point, **A**, **B**, **C** or **D**, will the centripetal force on the car be greatest?

Centripetal force is greatest at
(1 mark)

5 (c) (ii) What provides the centripetal force when the car goes round a bend?

.....
.....

(1 mark)

8

Turn over for the next question

Turn over ▶



- 6 (a) A student investigated the refraction of light as it passes out of a transparent plastic block.

She aimed a ray of light at point X. She marked the position of the ray as it passed through the transparent plastic block and into the air.

The angle i is the angle of incidence.

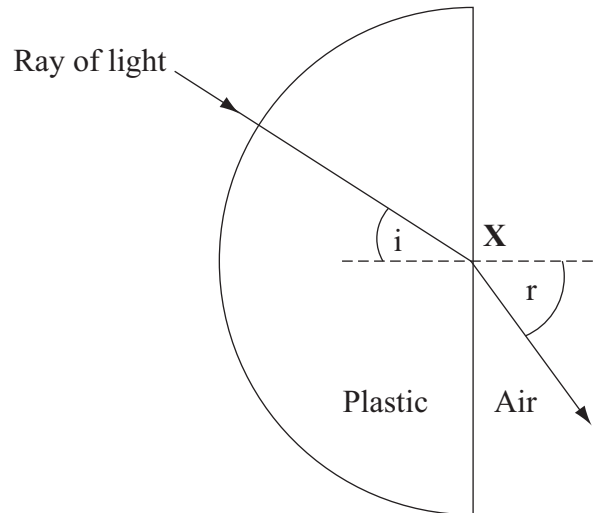

- 6 (a) (i) What is the name of angle r ?

.....
(1 mark)

- 6 (a) (ii) What is the name of the dashed line?

.....
(1 mark)



- 6 (b) A camera uses a lens to produce an image which falls on a light detector.



Name a light detecting device which may be used in a camera.

.....
(1 mark)

Question 6 continues on the next page

Turn over ►



6 (c) The diagram shows the position of an image formed in a camera.

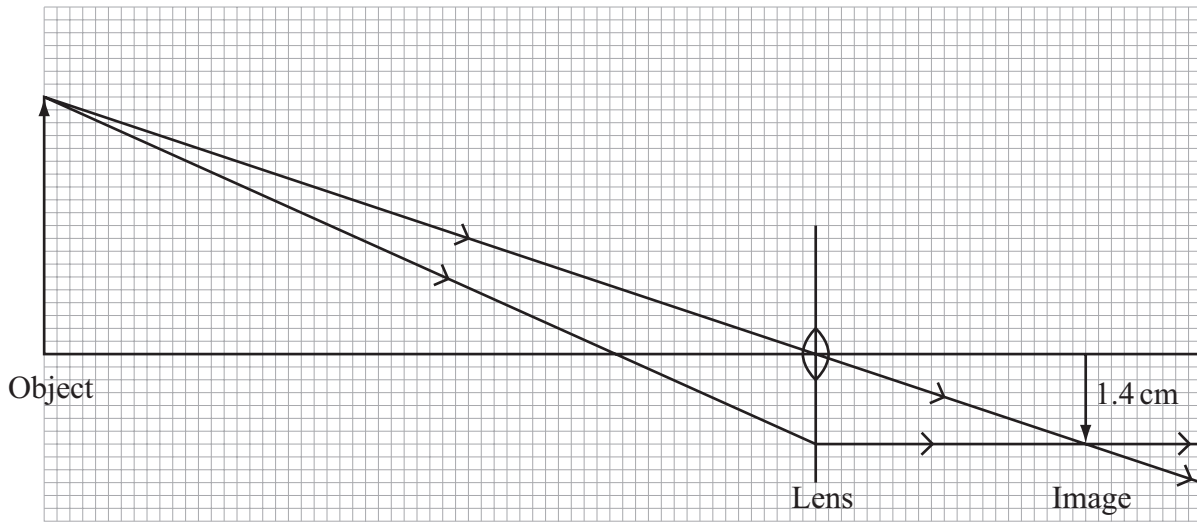

6 (c) (i) What type of lens is shown in the diagram?

.....
(1 mark)

6 (c) (ii) Use the equation in the box to calculate the magnification.

$$\text{magnification} = \frac{\text{image height}}{\text{object height}}$$

Show clearly how you work out your answer.

.....
.....

Magnification = (2 marks)

6 (d) Why does the image formed in a camera have to be a real image?

.....
.....

(1 mark)

7



- 7 (a) Thousands of artificial satellites are now in orbit around the Earth. A student used the Internet to collect information about four of them.

The table shows the data that the student collected.

Satellite	Altitude (= height above the surface of the Earth) in kilometres	Period of orbit in hours
A	300	1.5
B	850	1.7
C	20 000	12.0
D	36 000	24.0

- 7 (a) (i) What conclusion, on the relationship between the altitude of a satellite and its period of its orbit, can the student come to from this data?

.....

 (1 mark)

- 7 (a) (ii) Any conclusion from the data in the table may not be valid for all satellites.

Give **two** reasons.

1

 2

 (2 marks)

- 7 (b) The Moon is the Earth's only natural satellite.

Explain how the Moon stays in a nearly circular orbit around the Earth.

.....

 (2 marks)

Question 7 continues on the next page

Turn over ►



7 (c) Two students see a film in which people on a spaceship hear an explosion on another spaceship.

The students think that this is not possible. What scientific evidence supports their opinion?

.....
.....
(1 mark)

7 (d) Some people say that space should not be explored.

Do you agree with them? Explain your answer.

.....
.....
.....
(2 marks)

8

END OF QUESTIONS

ACKNOWLEDGEMENT OF COPYRIGHT-HOLDERS AND PUBLISHERS

Permission to reproduce all copyright material has been applied for. In some cases, efforts to contact copyright-holders have been unsuccessful and AQA will be happy to rectify any omissions of acknowledgements in future papers if notified.

Copyright © 2008 AQA and its licensors. All rights reserved.

