

General Certificate of Education
June 2006
Advanced Level Examination



GENERAL STUDIES (SPECIFICATION A)
Unit 5 Science, Mathematics and Technology

GSA5

Wednesday 14 June 2006 1.30 pm to 3.00 pm

For this paper you must have:

- an objective test answer sheet
- an 8-page answer book
- a black ball-point pen

You may use a calculator.

Time allowed: 1 hour 30 minutes

Instructions

- Use a black ball-point pen for recording your answers to Questions 1.1 to 1.20 on your objective test answer sheet.
- Use blue or black ink or ball-point pen for answering **one** question from Questions 2.1 to 2.6.
- Write the information required on the front of your answer book for Question 2. The *Examining Body* for this paper is AQA. The *Paper Reference* is GSA5.
- Answer **all of** Question 1 (1.1 to 1.20) using the answer sheet provided **and one** question from Questions 2.1 to 2.6 in your separate answer book.
- For each item in Question 1 there are several alternative responses. When you have selected the response which you think is the best answer to a question, mark this response on your answer sheet.
- Do all rough work in your answer book, **not** on your answer sheet.
- Hand in **both** your answer sheet **and** your essay answer book at the end of the examination.

Information

- The maximum mark for this paper is 45.
- This paper consists of **two** questions.
Question 1 contains 20 objective test questions based on a variety of exercises in spatial and mechanical relations. Each question carries 1 mark. No deductions will be made for wrong answers.
- **Question 2** consists of six alternative essay questions (2.1 to 2.6). 25 marks are allocated to your essay.

QUESTION 1

Answer Questions 1.1 to 1.20.

For each of **Questions 1.1 to 1.20** choose the answer you consider the best of the alternatives offered in **A, B, C** and **D**.

Basketball Drills

Questions 1.1 and 1.2

Basketball players have to practise many drills so they can control the ball without looking at it.

1.1 The instructions for the ‘around the body’ drill are:

Start with the ball in the left hand in front of the waist, change to the right hand which is behind the back and bring the ball back to the front of your waist.

The picture which best shows the path of the ball is

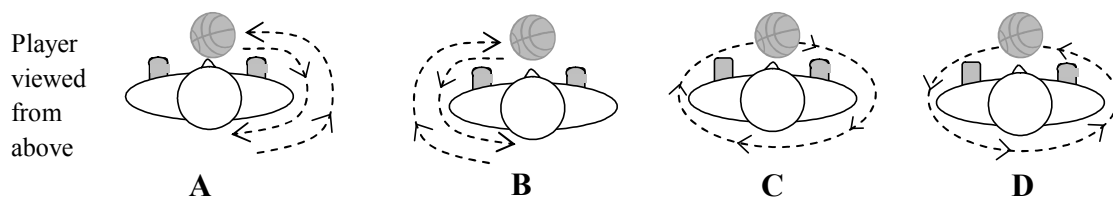

1.2 Another drill is ‘figure of eight’. Instructions for this drill are as follows:

With legs apart, pass the ball between your legs using your fingertips, as shown in the diagram below

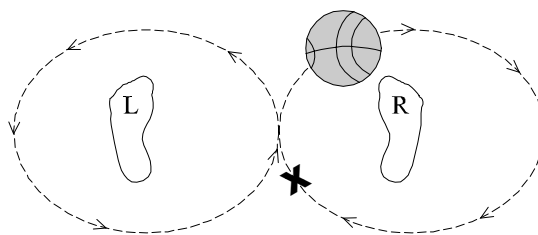

When the ball is at **X**, which of the following options describes the position of the player’s left arm and right arm relative to the body, respectively?

- | | | |
|----------|-------------------|--------------------|
| A | Left arm in front | Right arm in front |
| B | Left arm behind | Right arm behind |
| C | Left arm in front | Right arm behind |
| D | Left arm behind | Right arm in front |

Questions 1.3 and 1.4

Basketball players also practise the 'crabwalk'. The instructions for this drill are:

Stand with the left foot in front and the right foot behind. Hold the ball in the right hand between the legs with the right hand at the front and the left hand behind the left leg. Pass the ball to the left hand between the legs (pass 1). Both feet must be on the floor when the ball is passed. Then move the right foot forward and taking the ball round in front of the left knee, pass it through the legs to the right hand (pass 2) which is now behind the right knee. Then move the left foot forward again and so on, moving up the court.

1.3 Which diagram best shows the position of feet and hands for pass 1?

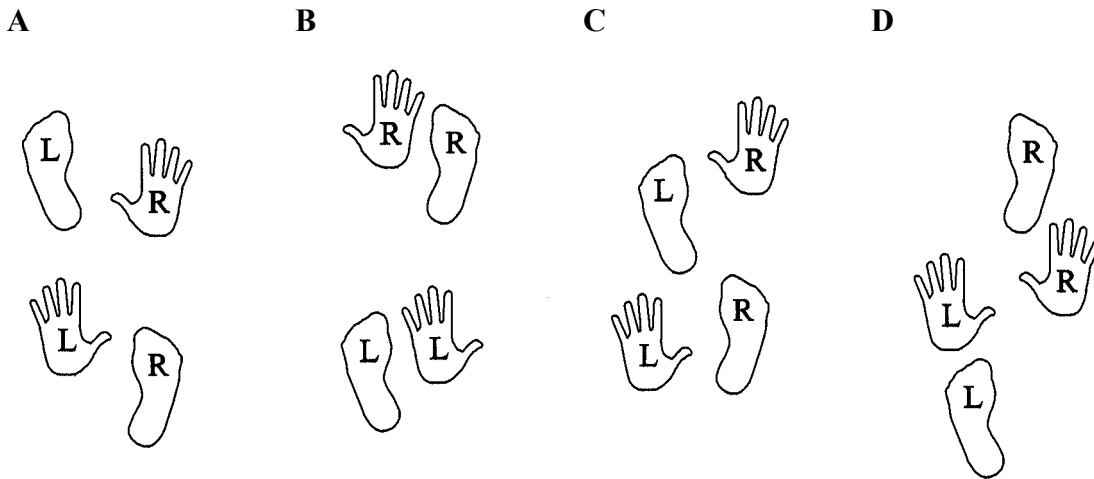

1.4 In the 'crab walk' the ball is always passed **from** the

- A front of one leg **to** the front of the other.
- B back of one leg **to** the back of the other.
- C back of one leg **to** the front of the other.
- D front of one leg **to** the back of the other.

Turn over for the next question

Turn over ▶

1.5 The ‘between the legs dribble’ is like the ‘crab walk’ but the ball is bounced on the floor and caught again instead of being passed from hand to hand. The first bounce and step is shown below.

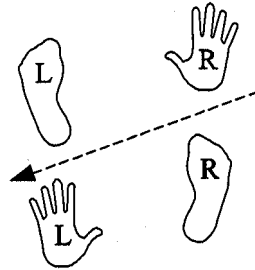

Which diagram below best shows the second step?

A

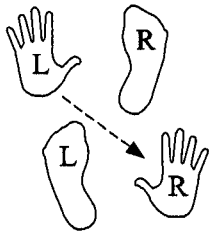

B

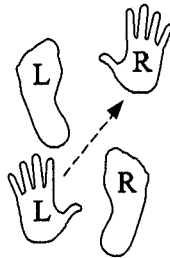

C

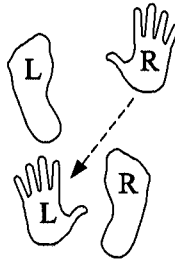

D

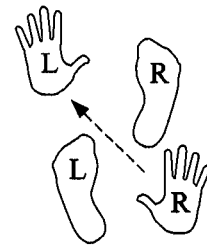

1.6 ‘Pivoting’ is rotating on the ball of the foot without shifting it. In a forward pivot the player faces the way he/she turns; in a reverse pivot the player’s back leads the turn.

A player performs a forward 180° pivot on his/her right foot. The start position is shown below.

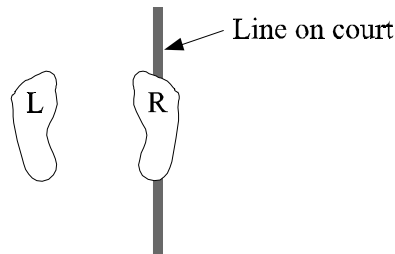

The diagram below that best shows the finish position is

A

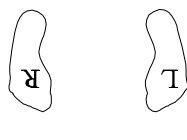

B

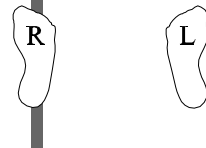

C

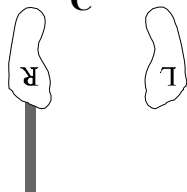

D

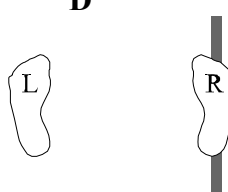

- 1.7 'Three man passing on the move' involves one ball and three players. The middle player passes to a player on one side, takes the return and then passes to the player on the other side, as the players move down the court.

Which diagram below best shows the path of the ball and players?

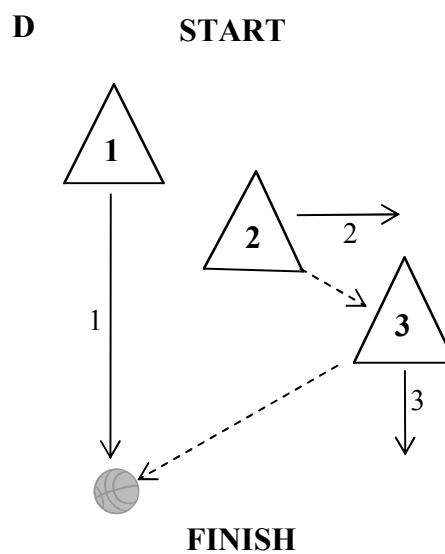
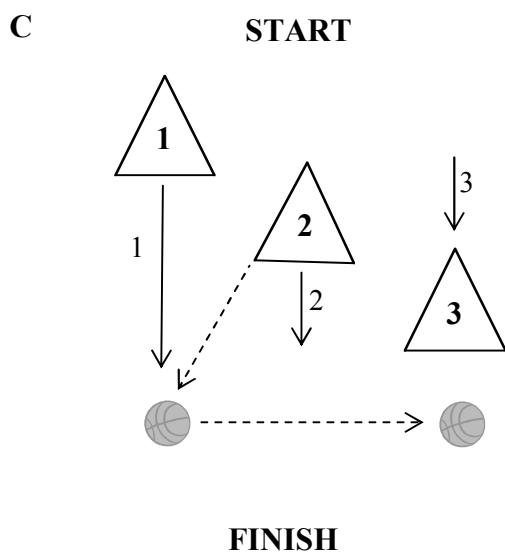
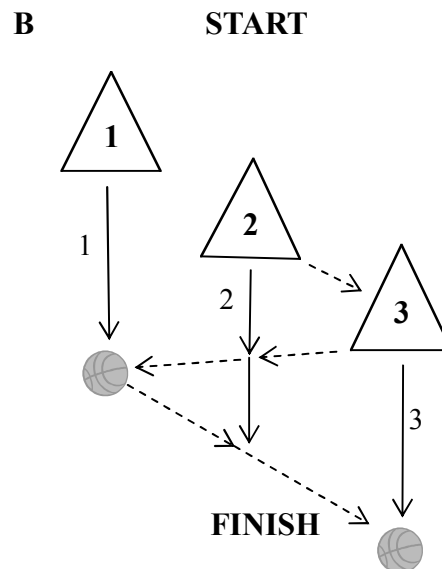
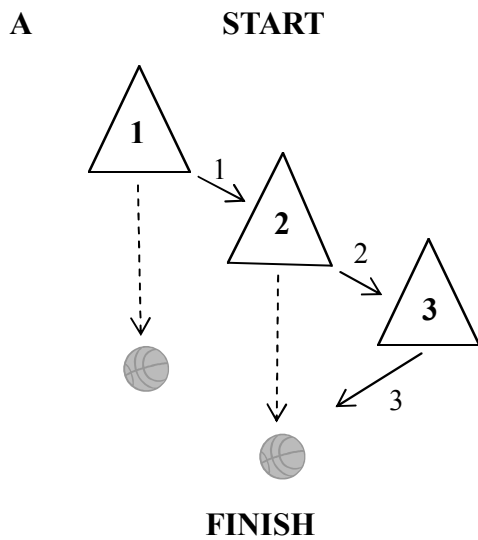
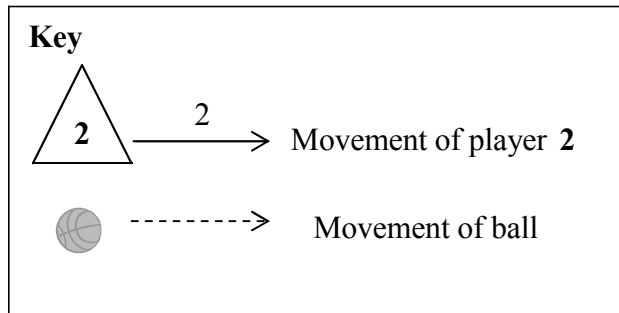

Turn over ►

Questions 1.8 to 1.10

The 'three man weave' is based on the 'three man passing on the move', but each time the ball is passed the passer follows the ball and runs around behind the receiver, who moves across the court as the players go forward. The diagram below shows the rough path of the ball and players.

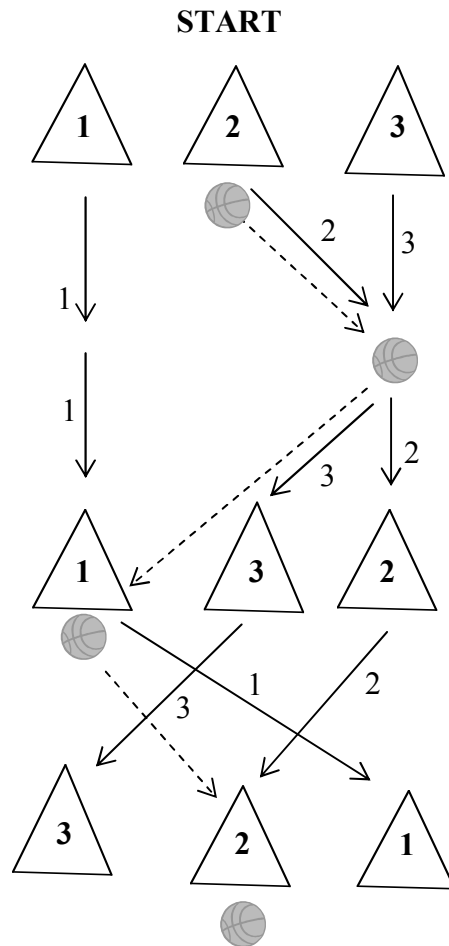

1.8 In the 'three man weave', the ball passes from player 2 to the other players in which sequence?

- A 1, 2, 3
- B 1, 3, 2
- C 3, 1, 2
- D 3, 2, 1

1.9 In the 'three man weave', player 1's path, viewed from his/her original position would be best represented as

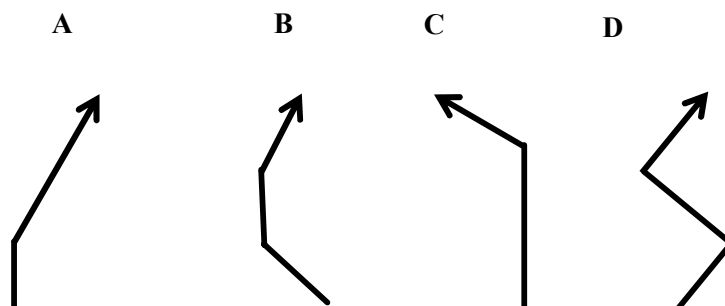

1.10 In the 'three man weave', if player 2 had passed to player 1 first, the progress down the court would have looked most like

A

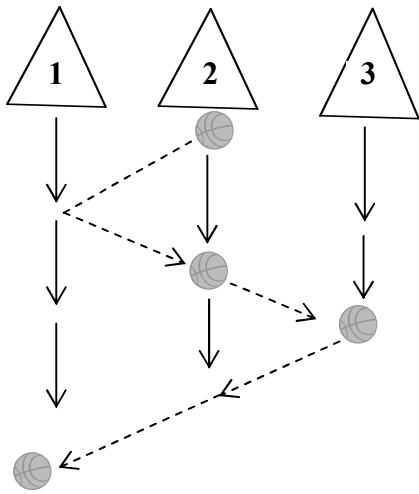

B

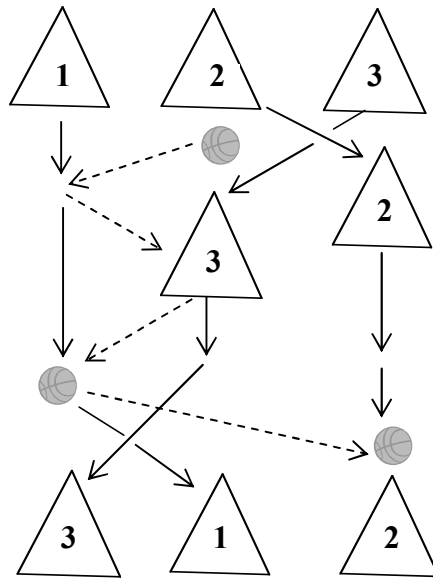

C

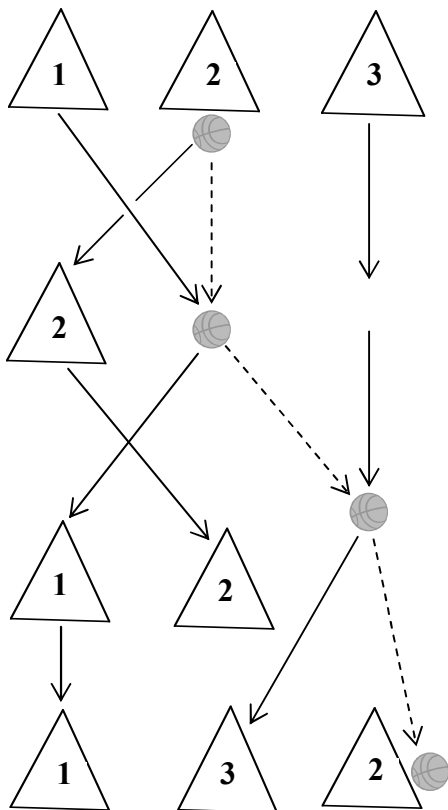

D

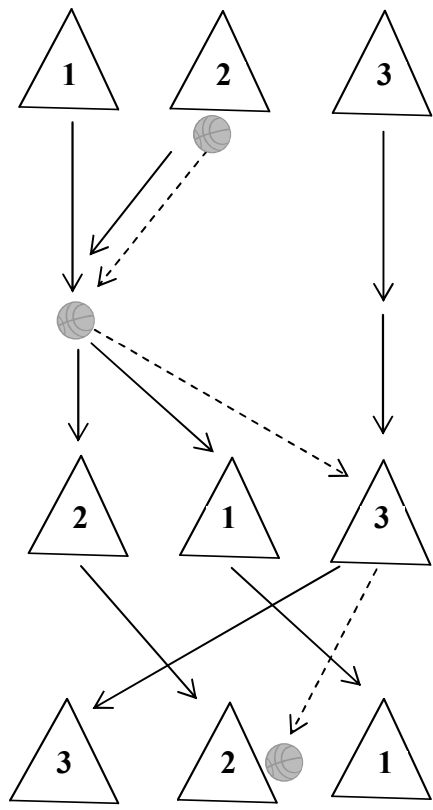

Turn over ►

Linkages

Linkages can change one form of motion (such as circular motion) to another (such as oscillating motion). They can also change the direction, speed or timing of motion. They form the basis of many mechanisms.

A four-bar linkage consists of four bars of various lengths pivoted at their ends or elsewhere.

Questions 1.11 and 1.12

In the four-bar linkage shown below P , Q , R and S are pivots about which the four bars can move freely in the plane of the paper.

$$PQ = SR = 6 \text{ cm.} \quad QR = PS = 4 \text{ cm.}$$

(Assume that the bars can move over each other if necessary.)

Figure 1

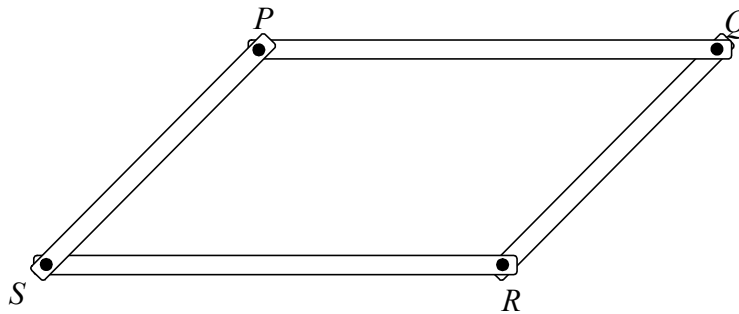

1.11 The maximum possible distance between P and R is

- A 4 cm
- B 6 cm
- C 7.2 cm
- D 10 cm

1.12 If PQ is fixed and PS rotates clockwise 360° , R can move

- A in a clockwise circle.
- B in an anticlockwise circle.
- C in a clockwise non-circular ellipse.
- D in an anticlockwise non-circular ellipse.

Question 1.13

A pantograph is a four-bar linkage mechanism used for drawing. It consists of two long bars and two short bars pivoted to one another so that they can move freely in the plane. In the version shown in **Figure 2** below the short bars are half the length of the long ones.

The point O is held fixed. There is a pointer at X and a pencil at Y . As the pointer at X is traced over a shape, the pencil at Y draws the shape enlarged by a factor of two.

Figure 2: A Pantograph

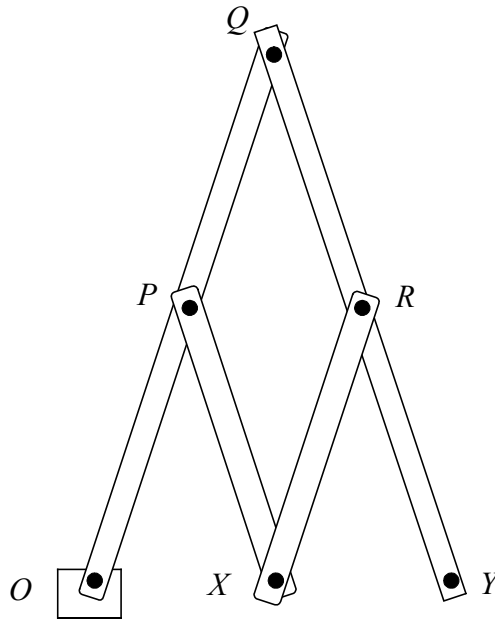

1.13 In **Figure 2** if O and Q are both held fixed, the point Y

- A cannot move.
- B can move on a circular path.
- C can move on a straight line.
- D can move freely.

Turn over for the next question

Turn over ▶

Questions 1.14 and 1.15

For **Questions 1.14** and **1.15**, select the answer from the diagrams labelled **A** to **D** in Figure 3.

Figure 3

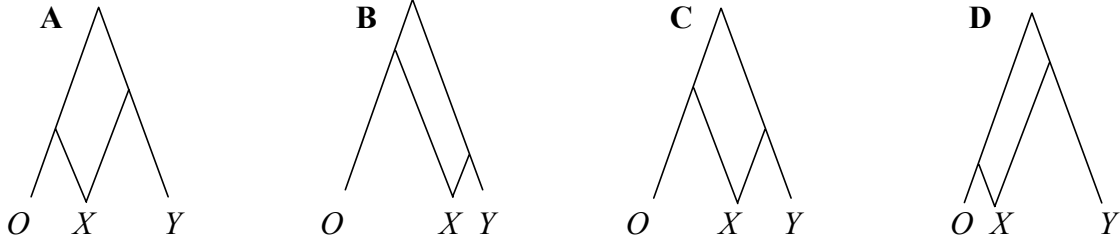

The size of the drawing traced out by the pencil depends upon the relative lengths of the bars in the pantograph.

1.14 Which of the pantographs in **Figure 3** will produce the biggest enlargement of the original shape?

1.15 Which of the pantographs in **Figure 3** will produce an enlargement with all the lengths two-and-a-half times the lengths of the original shape?

Clamping Devices

When an object is to be drilled it may be held still by clamping.

Figure 4 below shows directions of transverse movement and of rotations. Movement of the object can be prevented either by simple pegs called 'positive restraint' or by gripping the object, which relies on friction.

Figure 4: Six degrees of freedom

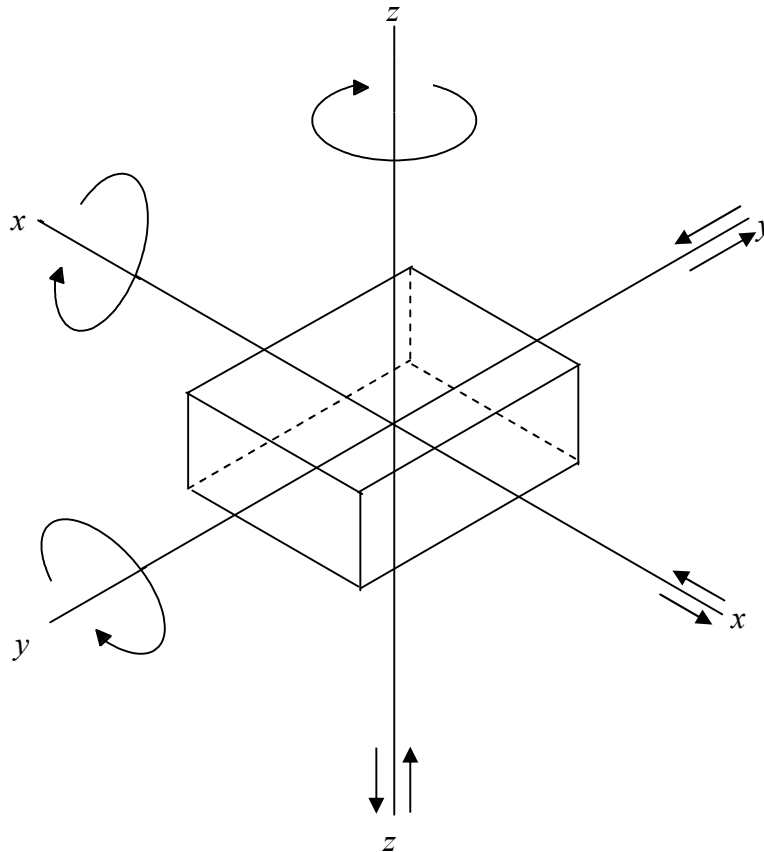

1.16 When an object is placed on a fixed base plate, the base plate will stop

- 1 transverse movement either way in the x direction.
- 2 transverse movement down in the z direction.
- 3 rotation around the x axis.
- 4 rotation around the z axis.

Answer

- A if 1 and 2 only are correct
- B if 2 and 3 only are correct
- C if 3 and 4 only are correct
- D if 1, 2 and 3 only are correct

Turn over ►

1.17 The diagram below shows an object being restrained by the use of two pegs.

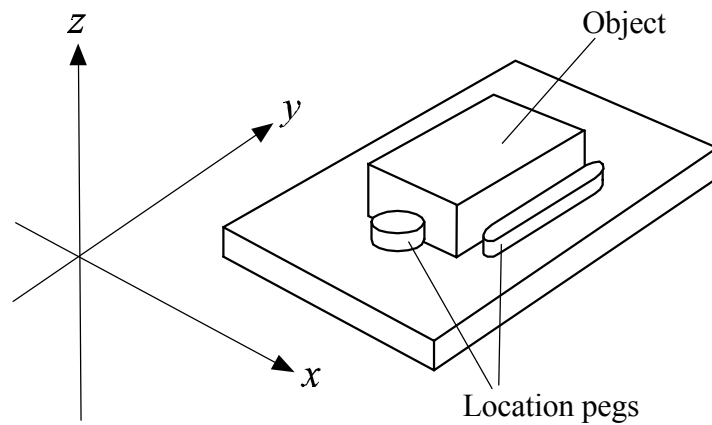

The pegs provide restraint to prevent

- A transverse movement of the object either way in the x direction.
- B transverse movement of the object either way in the z direction.
- C rotation of the object around the x axis.
- D rotation of the object around the z axis.

Questions 1.18 and 1.19

A vice holds a cylindrical object using a combination of positive restraint and friction. The vee block provides a positive restraint on the object.

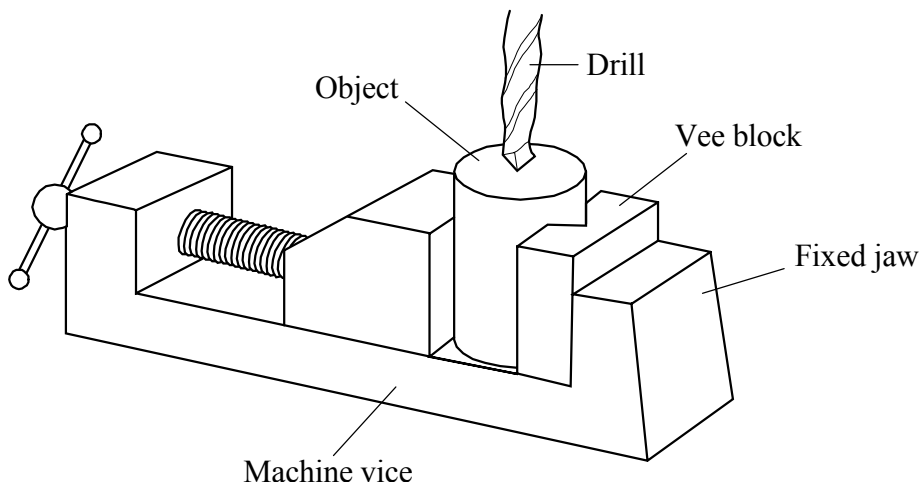

1.18 The restraints shown by the vice can be summarised by drawing appropriate axes and labelling each as either p for positive restraint or f for frictional restraint.

Which one of the following diagrams represents the restraints against transverse movement imposed by the vice?

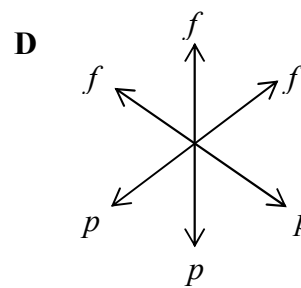
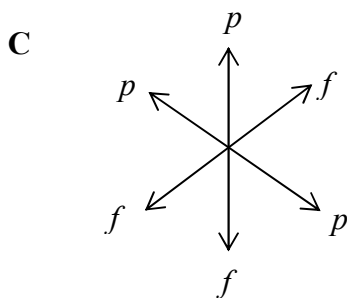
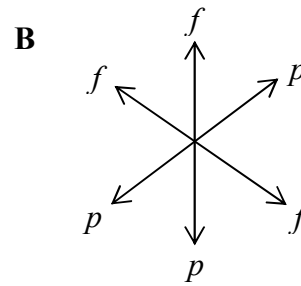
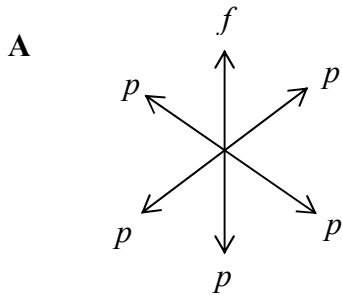

1.19 The axes that show the correct restraints against rotation provided by the vice are

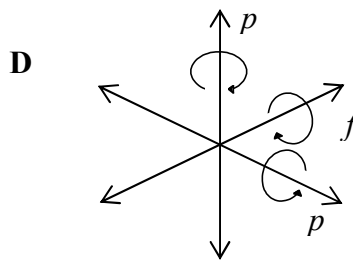
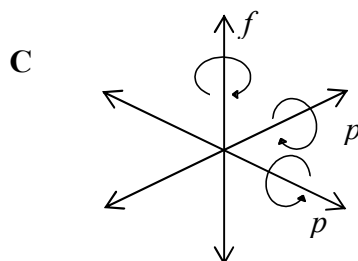
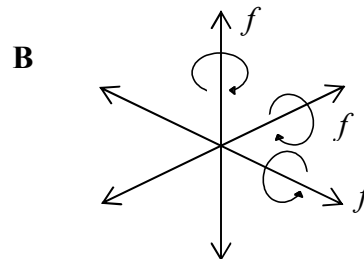
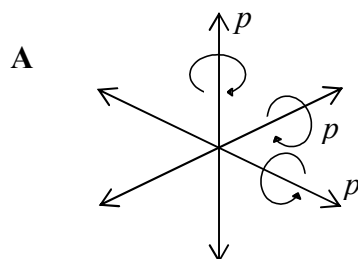

Turn over ►

1.20 There are many clamps which tighten with a screw action, but to work on similar objects repetitively it is much easier to use a 'quick action clamp'. These may use a cam, as in the example below.

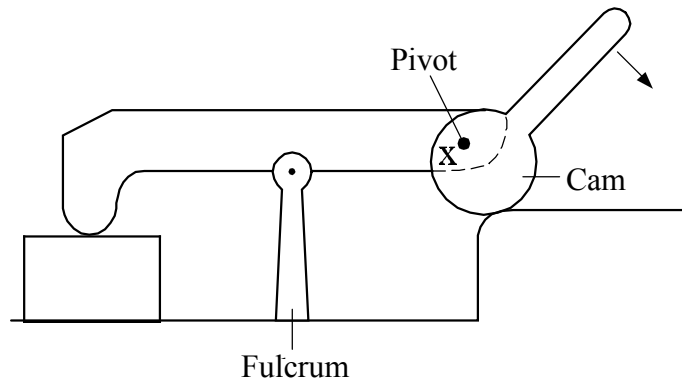

If the cam handle on the right is moved down and to the right (in the direction of the arrow)

- A** the height of the pivot decreases and the clamp grips the object.
- B** the height of the pivot decreases and the clamp releases the object.
- C** the height of the pivot increases and the clamp grips the object.
- D** the height of the pivot increases and the clamp releases the object.

END OF QUESTION 1

QUESTION 2

Answer **one** of Questions **2.1** to **2.6** in English.

There are 25 marks for each question.

This question must be answered in a **separate** answer book which must be clearly labelled **GSA5 Question 2**.

Write your answer in continuous prose as if you are addressing the intelligent general reader. Include relevant science wherever appropriate. You are reminded of the need for good English and clear presentation. Quality of Written Communication will be assessed in this answer.

2.1 How can music be explained scientifically?

Discuss how and why music affects us in different ways, for example emotionally, psychologically and physiologically.

2.2 Examine the technological achievements of the NASA space shuttle.

Evaluate its contribution to space exploration and other aspects of modern living.

2.3 Examine the scientific and technological developments that have contributed to mass transport systems.

To what extent are fast, affordable and convenient mass transport systems desirable and sustainable?

2.4 Explain how oil is refined and processed for different applications.

Discuss the problems raised by our dependence on oil and consider the extent to which there are viable alternatives.

2.5 Using one or more sports for illustration, discuss the part played by science and technology in improving sporting skills and achievement.

2.6 Explain the part that technology plays in allowing employment to be home-based.

Discuss the implications of home-based working for people in different occupations.

END OF QUESTIONS

There are no questions printed on this page

ACKNOWLEDGEMENT OF COPYRIGHT-HOLDERS AND PUBLISHERS.

Permission to reproduce all copyright material has been applied for. In some cases, efforts to contact copyright-holders have been unsuccessful and AQA will be happy to rectify any omissions of acknowledgements in future papers if notified.

Copyright © 2006 AQA and its licensors. All rights reserved.