

# Administrative Procedures Academic Year 2009-2010

**GCE (including GCE in Applied Subjects)**

Advanced Subsidiary/Advanced Level  
Continuing and New Specifications

**Basic Skills Tests and Key Skills**

**Extended Project Qualification  
(AQA-City & Guilds)**

**FSMQ  
(Free-standing Mathematics Qualifications)**

Applicable in the academic year 2009-2010 from September 2009



**Administrative Procedures 2009-2010**  
**GCE (including GCE in Applied Subjects)**  
**GCE New Specifications,**  
**Basic and Key Skills, FSMQ and**  
**Extended Project Qualification (AQA-City & Guilds)**

**Contents**

<b>1</b>	<b>Introduction</b> .....	<b>4</b>
<b>2</b>	<b>Examination series</b> .....	<b>5</b>
<b>3</b>	<b>Administrative timetable</b> .....	<b>6</b>
<b>4</b>	<b>Entry procedures</b> .....	<b>9</b>
	Subject Awards .....	9
	GCE (including GCE in Applied Subjects) Entry Requirements .....	16
	Key Skills, Wider Key Skills and Basic Skills Tests .....	17
	Free-Standing Mathematics Qualifications Entry Requirements .....	18
	Stages in the Entries Procedure .....	19
	e-AQA.....	20
<b>5</b>	<b>Candidate identifiers</b> .....	<b>21</b>
	Unique Candidate Identifier (UCI) .....	21
	Unique Learner Number (ULN) .....	22
<b>6</b>	<b>Fees</b> .....	<b>23</b>
<b>7</b>	<b>Conduct of examinations and externally-assessed assignments</b> .....	<b>25</b>
<b>8</b>	<b>Internal assessment</b> .....	<b>28</b>
<b>9</b>	<b>Estimated grades</b> .....	<b>31</b>
<b>10</b>	<b>Aggregation and grading</b> .....	<b>32</b>
	GCE AS/Advanced Grading .....	32
	GCE in Applied Subjects AS/Advanced Grading .....	36
	GCE (including GCE in Applied Subjects) Entry, Aggregation and Certification Rules .....	39
	Key Skills Grading/Aggregation .....	40
	FSMQ and AS Use of Mathematics Grading/Aggregation .....	40
	Transfer of Credit .....	41
<b>11</b>	<b>Late Awards</b> .....	<b>42</b>
<b>12</b>	<b>Special circumstances</b> .....	<b>43</b>
	Irregularities and Late Arrivals .....	43
	Access Arrangements .....	43
	Special Consideration .....	43
	Candidates who change centres .....	43
<b>13</b>	<b>Results</b> .....	<b>44</b>
<b>14</b>	<b>Enquiries about results</b> .....	<b>45</b>
	<b>Appendix A: Availability of examinations 2009-2010</b> .....	<b>46</b>
	<b>Appendix B: Exemptions from Key Skills – Proxy Qualifications</b> .....	<b>59</b>
	<b>Appendix C: Key Skills Proxy Entry Codes</b> .....	<b>65</b>
	<b>Appendix D: JCQ Notice to centres: Withdrawal of Curriculum 2000 specifications</b> ..	<b>66</b>

# 1 Introduction

- 1.1. The purpose of this document is to assist Examinations Officers and teachers with the administration of the unit assessments and subject awards in the following qualifications:
  - GCE at Advanced Subsidiary and Advanced Level including new specifications
  - GCE in Applied Subjects at Advanced Subsidiary, Single Award (3 units) and Double Award (6 units)
  - GCE in Applied Subjects at Advanced Level, Single Award (6 units), Advanced GCE with Additional Subsidiary GCE (additional) (9 units) and Double Award (12 units)
  - Basic Skills Tests and Key Skills
  - Extended Project Level 3 (AQA-City & Guilds)
  - Free-Standing Mathematics Qualifications (FSMQ)
- 1.2. All references to AS in this document should be read as Advanced Subsidiary.
- 1.3. This document should be read in conjunction with AQA subject specific Specifications, which give details of the schemes of assessment, and the Entry Procedures and Codes booklet, which covers all examination series in the 2009-2010 academic year.
- 1.4. Copies of AQA Specifications can be downloaded from the AQA Website at [www.aqa.org.uk/qual/index.php](http://www.aqa.org.uk/qual/index.php)
- 1.5. Details of how to purchase additional copies of Specifications are given at [www.aqa.org.uk/public/index.php](http://www.aqa.org.uk/public/index.php)
- 1.6. The availability of units at each examination series is shown in Appendix A (page 46).

## 2 Examination series

2.1. For the academic year 2009-2010, AQA will offer:

- Two series of examinations/assessments in January 2010 and June 2010 for GCE (including GCE in Applied Subjects) and FSMQ.
- Six series of Key Skills and Basic Skills assessments, in October 2009, November 2009, January 2010, March 2010, May 2010 and June 2010.

2.2. Details of the examination series for the above qualifications in 2009-2010 are shown below.

Series & Year Code	Series Title	Type(s) of Examination	Entry Closing Date
AK09	October 2009 Series AK	Key Skills Levels 1 and 2 Tests Basic Skills Levels 1 and 2 Tests (Literacy & Numeracy)	7 September 2009
BK09	November 2009 Series BK	Key Skills Levels 1 and 2 Tests Basic Skills Levels 1 and 2 Tests (Literacy & Numeracy)	21 September 2009
BG09	November 2009 Series BG	Extended Project Qualification (AQA-City & Guilds)	4 October 2009
1A10	January 2010 Series 1A	GCE (Outgoing) A2 Units and AS and Advanced Awards <b>(Final opportunity for assessment and award)</b> GCE (Continuing Specification) Mathematics & Statistics Units and Awards GCE (New Specifications) AS and A2 Units & AS Awards GCE in Applied Subjects Units and Awards FSMQ (Foundation and Intermediate only)	21 October 2009
1K10	January 2010 Series 1K	Key Skills Levels 1, 2, and 3 Tests Key Skills Proxy Claims Key Skills Portfolio Assessments Key Skills Wider Key Skills Qualification Key Skills Unit Awards Basic Skills Levels 1 and 2 Tests (Literacy & Numeracy)	9 November 2009
3K10	March 2010 Series 3K	Key Skills Levels 1, 2, and 3 Tests Key Skills Proxy Claims Key Skills Portfolio Assessments Key Skills Wider Key Skills Qualification Key Skills Unit Awards Basic Skills Levels 1 and 2 Tests (Literacy & Numeracy)	11 January 2010
5K10	May 2010 Series 5K	Key Skills Levels 1 and 2 Tests Basic Skills Levels 1 and 2 Tests (Literacy & Numeracy)	21 March 2010
6A10	June 2010 Series 6A	GCE (New Specification) Units and Awards GCE (Continuing Specification) Mathematics, Statistics and Use of Mathematics Units and Awards GCE in Applied Subjects Units and Awards Extended Project Qualification (AQA-City & Guilds) FSMQ	21 March 2010
6K10	June 2010 Series 6K	Key Skills Levels 1, 2, 3, and 4 Tests Key Skills Proxy Claims Key Skills Portfolio Assessments Key Skills Wider Key Skills Qualification Key Skills Unit Awards Basic Skills Levels 1 and 2 Tests (Literacy and Numeracy)	31 March 2010

### 3 Administrative timetable

The table below and overleaf provides a summary of the dates by which the main administrative procedures must be completed in 2009-2010.

Date	Action
21 July 2009	Last date for notifying AQA (via e-AQA or return of booklet) of <ul style="list-style-type: none"> <li>• <i>Intention to Enter</i> for all Examination Series within the Academic Year 2009/2010</li> <li>• <i>Estimated Entries</i> for October 2009, November 2009 and January 2010 examinations</li> </ul>
28 August 2009	Last date for <ul style="list-style-type: none"> <li>• receipt of requests for June 2009 GCE (including GCE in Applied Subjects)/Key Skills Level 3 Tests priority photocopies of examination scripts for enquiry about results purposes</li> <li>• requests for the accelerated enquiry about results service</li> </ul>
7 September 2009	Last date for October 2009 Key Skills and Basic Skills Test entries (Series AK09)
10 September 2009	Last date for centres to receive GCE (including GCE in Applied Subjects)/Key Skills Level 3 Tests priority photocopies of examination scripts for enquiry about results purposes for June 2009
15 September 2009	Last date for notifying AQA (via return of booklet) of <i>Initial Entry Information</i> for the January 2010 GCE A2 final resit opportunity
20 September 2009	Last date <ul style="list-style-type: none"> <li>• for requesting a results enquiry for June 2009</li> <li>• to apply for late cash-in (aggregation) of units to obtain subject awards for June 2009</li> </ul>
21 September 2009	Last date for November 2009 Key Skills and Basic Skills Test entries (Series BK09)
October 2009	Issue of certificates for June 2009 series
4 October 2009	Last date for receipt of requests for original GCE (including GCE in Applied Subjects) and Key Skills Level 3 examination scripts for June 2009
4 October 2009	Last date for November 2009 Extended Project Qualification (AQA-City & Guilds) entries (Series BG09)
10 October 2009	Last date for notifying AQA (via e-AQA or return of booklet) of <i>Estimated Entries</i> for June 2010 and March and June 2010 Key Skills
21 October 2009	Last date for January 2010 GCE (including GCE in Applied Subjects) and FSMQ entries (Series 1A10)
5 November 2009	Last date for submission of coursework marks for Extended Project Qualification (AQA-City & Guilds) (Series BG09)
9 November 2009	Last date for January 2010 Key Skills and Basic Skills Test entries (Series 1K10)
19 November 2009	Receive results for October 2009 Key Skills and Basic Skills Tests (Series AK09)
1 December 2009	Last date for requests for Transferred Candidates for January 2010 examinations

Date	Action
17 December 2009	Last date for requesting a results enquiry for October 2009 Key Skills
11 January – 3 February 2010	January examination period
10 January 2010	Last date for <ul style="list-style-type: none"> <li>• submission of January 2010 Key Skills Portfolio Levels 1-4</li> <li>• submission of estimated grades for January 2010 units</li> <li>• submission of coursework marks for January 2010 series</li> <li>• submission of FSMQ Portfolio Marks</li> </ul>
11 January 2010	Last date for March 2010 Key Skills and Basic Skills Test entries (Series 3K10)
14 January 2010	Receive results for November 2009 Key Skills and Basic Skills Tests (Series BK09)
10 March 2010	Last date for submission of March 2010 Key Skills Portfolio Levels 1 to 4
11 March 2010	Results publication date for January 2010 GCE (including GCE in Applied Subjects), FSMQ, Key and Basic Skills Tests (Series 1A10 and 1K10)
19 March 2010	Last date for receipt of requests for GCE (including GCE in Applied Subjects) priority photocopies of examination scripts for enquiry about results purposes for January 2010
21 March 2010	Last date for <ul style="list-style-type: none"> <li>• May 2010 Key Skills and Basic Skills Test entries (Series 5K10)</li> <li>• June 2010 GCE (including GCE in Applied Subjects), FSMQ and Extended Project Qualification (AQA-City &amp; Guilds) entries (Series 6A10)</li> </ul>
31 March 2010	Last date for June 2010 Key Skills and Basic Skills Tests entries (Series 6K10)
1 April 2010	Last date for centres to receive GCE (including GCE in Applied Subjects) priority photocopies of examination scripts for enquiry about results purposes for January 2010
12 April 2010	Last date <ul style="list-style-type: none"> <li>• for requesting a results enquiry for January 2010</li> <li>• to apply for late cash-in (aggregation) of units to obtain subject awards for January 2010</li> </ul>
19 April 2010	Last date for requests for Transferred Candidate arrangements for Summer 2010
28 April 2010	Last date to apply for return of original GCE (including GCE in Applied Subjects) and Key Skills Level 3 examination scripts for January 2010
May 2010	Issue of certificates for January 2010 series
6 May 2010	Receive results for March 2010 Key Skills and Basic Skills Tests

Date	Action
15 May 2010	Last date for <ul style="list-style-type: none"> <li>• submission of GCE (including GCE in Applied Subjects) coursework marks (<b>except</b> Art and Design, Dance and Drama and Theatre Studies) for June 2010 series (see 31 May also)</li> <li>• submission of coursework marks for Extended Project Qualification (AQA-City &amp; Guilds) for June 2010 series</li> <li>• submission of FSMQ coursework portfolio marks for June 2010 series</li> <li>• submission of estimated grades for externally-assessed units for June 2010 series</li> </ul>
17 May-30 June 2010	June 2010 examination period
31 May 2010	Last date for <ul style="list-style-type: none"> <li>• submission of coursework marks for GCE Art and Design, Dance and Drama and Theatre Studies</li> <li>• submission of coursework marks for GCE Applied Art &amp; Design</li> <li>• submission of June 2010 Key Skills Portfolio Levels 1 to 4</li> </ul>
3 June 2010	Last date for requesting a results enquiry for March 2010 Key Skills and Basic Skills Tests
9 June 2010	Last date for centres to receive original GCE (including GCE in Applied Subjects) and FSMQ examination scripts for January 2010.
24 June 2010	Receive results for May 2010 Key Skills and Basic Skills Tests
21 July 2010	Last date for notifying AQA (via e-AQA or return of booklet) of <ul style="list-style-type: none"> <li>• <i>Intention to Enter</i> for all Examination Series within the Academic Year 2010/2011</li> <li>• <i>Estimated Entries</i> for October 2010, November 2010 and January 2011</li> </ul>
19 August 2010	Receive <ul style="list-style-type: none"> <li>• unit results and subject awards for June 2010 series</li> <li>• results for June 2010 Key Skills and Basic Skills Tests</li> </ul>
27 August 2010	Last date for <ul style="list-style-type: none"> <li>• receipt of requests for June 2010 GCE (including GCE in Applied Subjects) priority photocopies of examination scripts for enquiry about results purposes</li> <li>• requests for the accelerated enquiry about results service</li> </ul>
10 September 2010	Last date for centres to receive GCE (including GCE in Applied Subjects)/Key Skills Level 3 Tests priority photocopies of examination scripts for enquiry about results purposes for June 2010
20 September 2010	Last date <ul style="list-style-type: none"> <li>• for requesting a results enquiry for June 2010</li> <li>• to apply for late cash-in (aggregation) of units to obtain subject awards for June 2010</li> </ul>
4 October 2010	Last date for receipt of requests for original GCE (including GCE in Applied Subjects) and Key Skills Level 3 examination scripts for June 2010
October 2010	Issue of certificates for June 2010 series

## 4 Entry procedures

- 4.1 Entries can be accepted only from centres that are approved by AQA (see paragraph 4.22). AQA does not require the prior registration of candidates for any of the qualifications detailed in this booklet.
- 4.2 Entries may be made by **EDI**, **online via e-AQA**, on **Disks**, or on **Entry Forms** prior to the closing date for entry, but **only one** of these methods must be used for entries for a particular series.
- 4.3 A separate entry is required in the particular series for the following:
- All units on which candidates are being assessed (continuing GCE specifications use a four character code; new GCE specifications use a five character code)
  - Every assessment for which a subject award result is to be reported (using a four digit code, or four digits plus an identifying letter for GCE Art and Design awards)
  - Individual test and portfolio components for Key Skills

Subject results will only be awarded at GCE (including GCE in Applied Subjects) AS or A level or Key Skills, when the appropriate subject award entry (claim) has been made.

The diagrams on pages 10 to 15 illustrate the assessment and entry structures for AQA GCE (including GCE in Applied Subjects) and Key Skills specifications. Entry requirements are indicated by **bold** boxes. The codes given in bold type in these boxes are entry codes.

### Subject Awards

- 4.4 Once entries for subject awards have been received (after 21 October 2009 for January 2010 or 21 March for June 2010) AQA will check
- whether each candidate will have sufficient unit results (from previous examination series or from unit entries in the current series) to qualify for the subject award entered.  
Centres will be advised via the *Certification Warning Report (Unsubstantiated Entries)* if a candidate will not have sufficient unit results, so that additional units may be entered, or the entry for the subject award may be amended (for example, from an Advanced to an AS award) or withdrawn.
  - where no entry for a subject award has been made but where candidates are entered for sufficient units to achieve an Advanced subject award. Centres will be notified of any such candidates via the *Certification Warning Report (Potential Entries)*.  
**Note:** Centres are urged to make subject award entries by 21 October or 21 March in all cases where candidates wish to receive subject awards and will have taken sufficient units to qualify. Although subject awards can be requested in the 4 weeks immediately after the publication of results, candidates will face a delay in receiving their subject grades. See Section 11 for further information.
- 4.5 Entries for individual units (and for components in Key Skills) will incur entry fees, as shown in Section 6. Entries to re-sit a unit or component incur the full entry fee for the unit or component. There are no fees payable for entries (claims) for the aggregation of unit results to give subject awards (but see paragraph 11.1). Similarly, there are no fees for entries (claims) for main Key Skills awards.

Example of GCE Assessment and Entry Structure  
Continuing Specifications

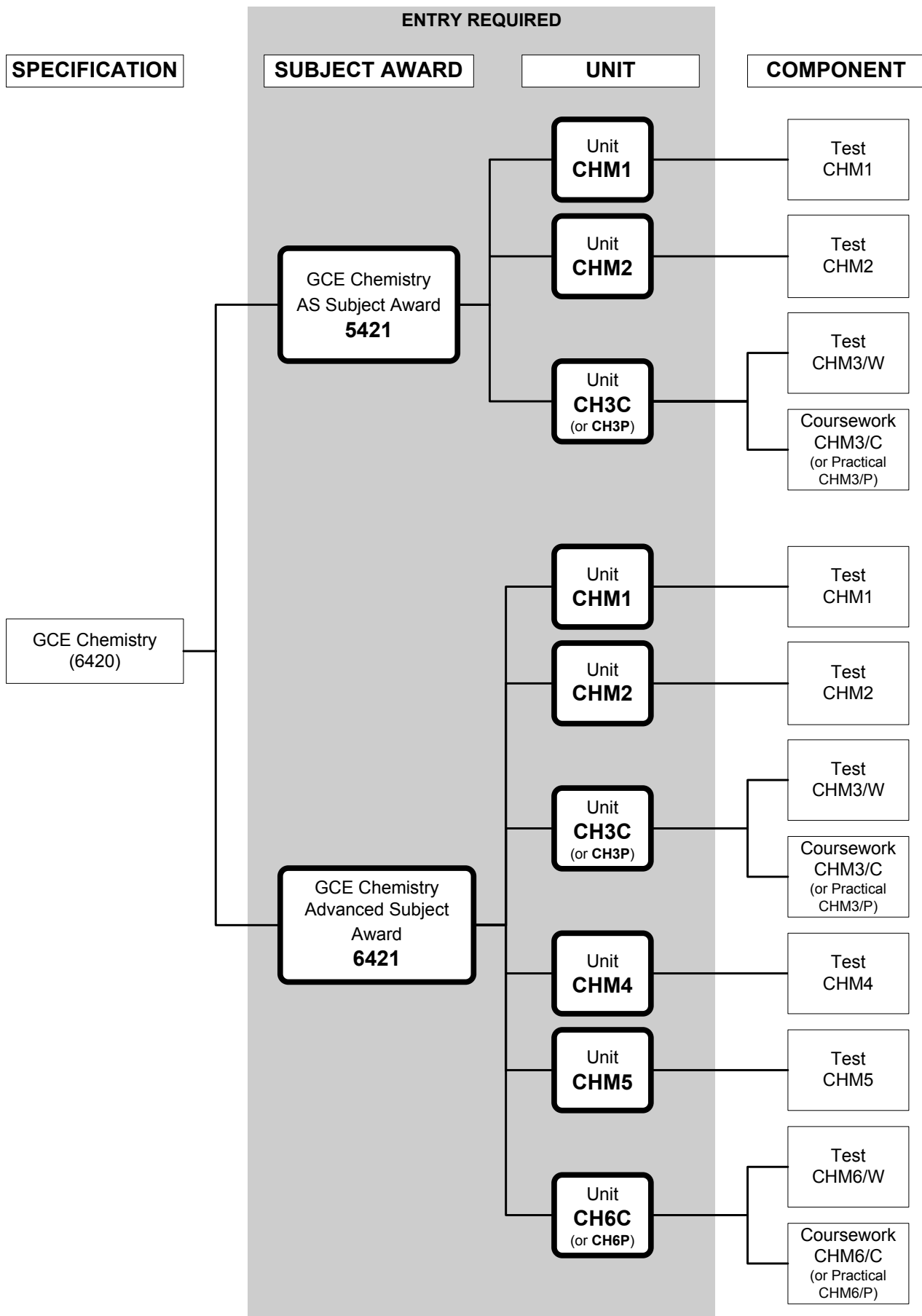

Example of GCE in Applied Subjects  
Assessment and Entry Structure

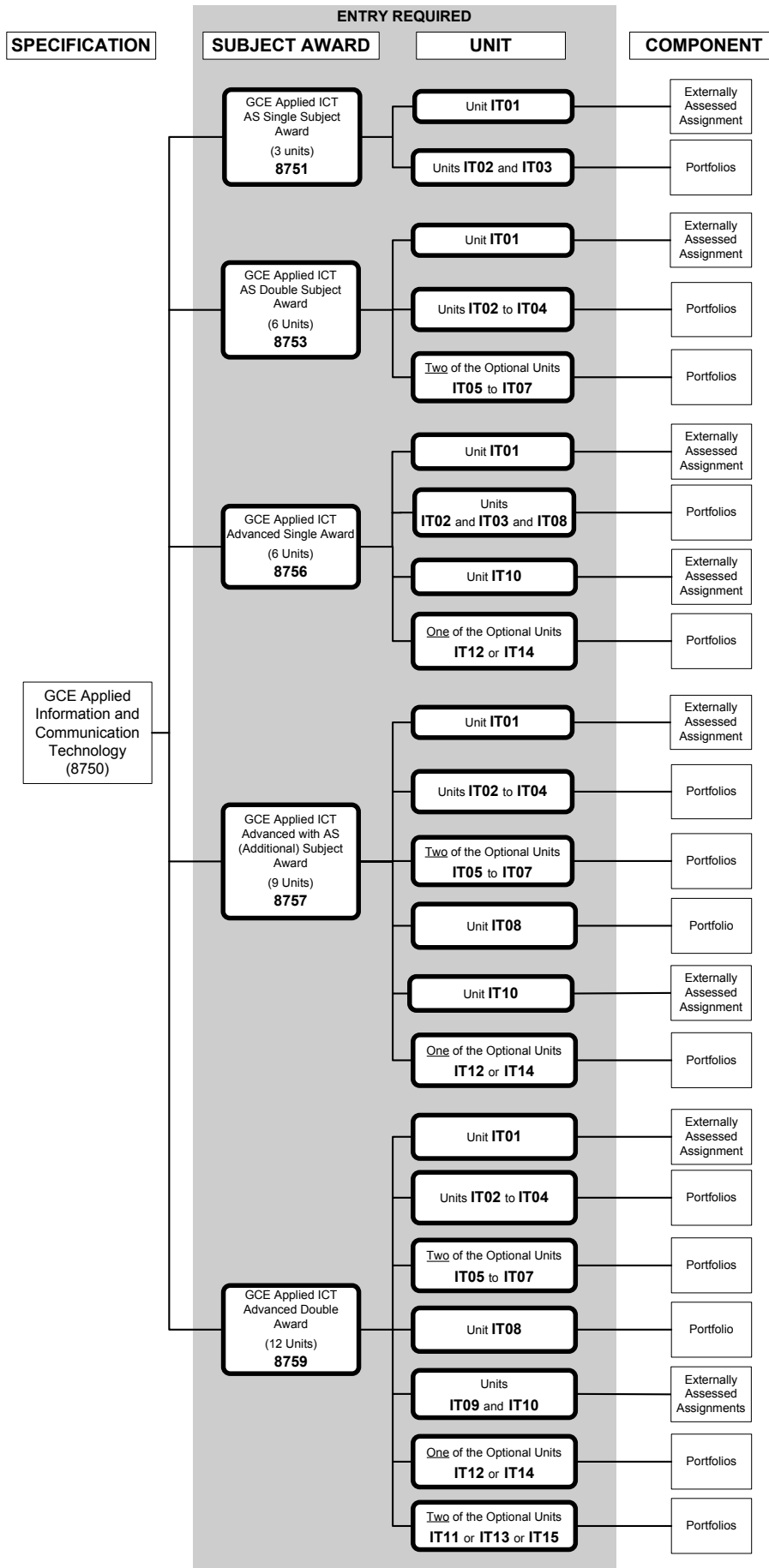

Example of 2-unit award new GCE assessment and entry structure  
GCE Polish

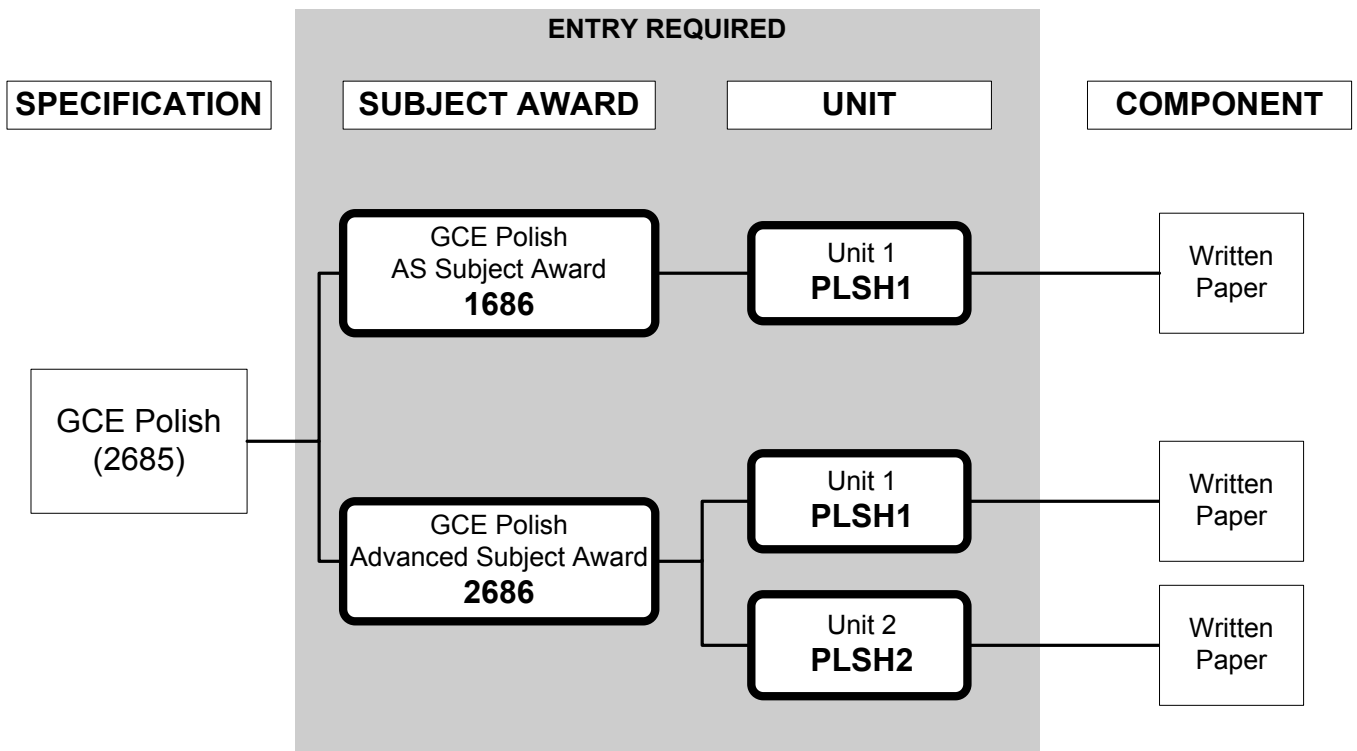

Example of 4-unit award new GCE assessment and entry structure  
GCE Drama and Theatre Studies

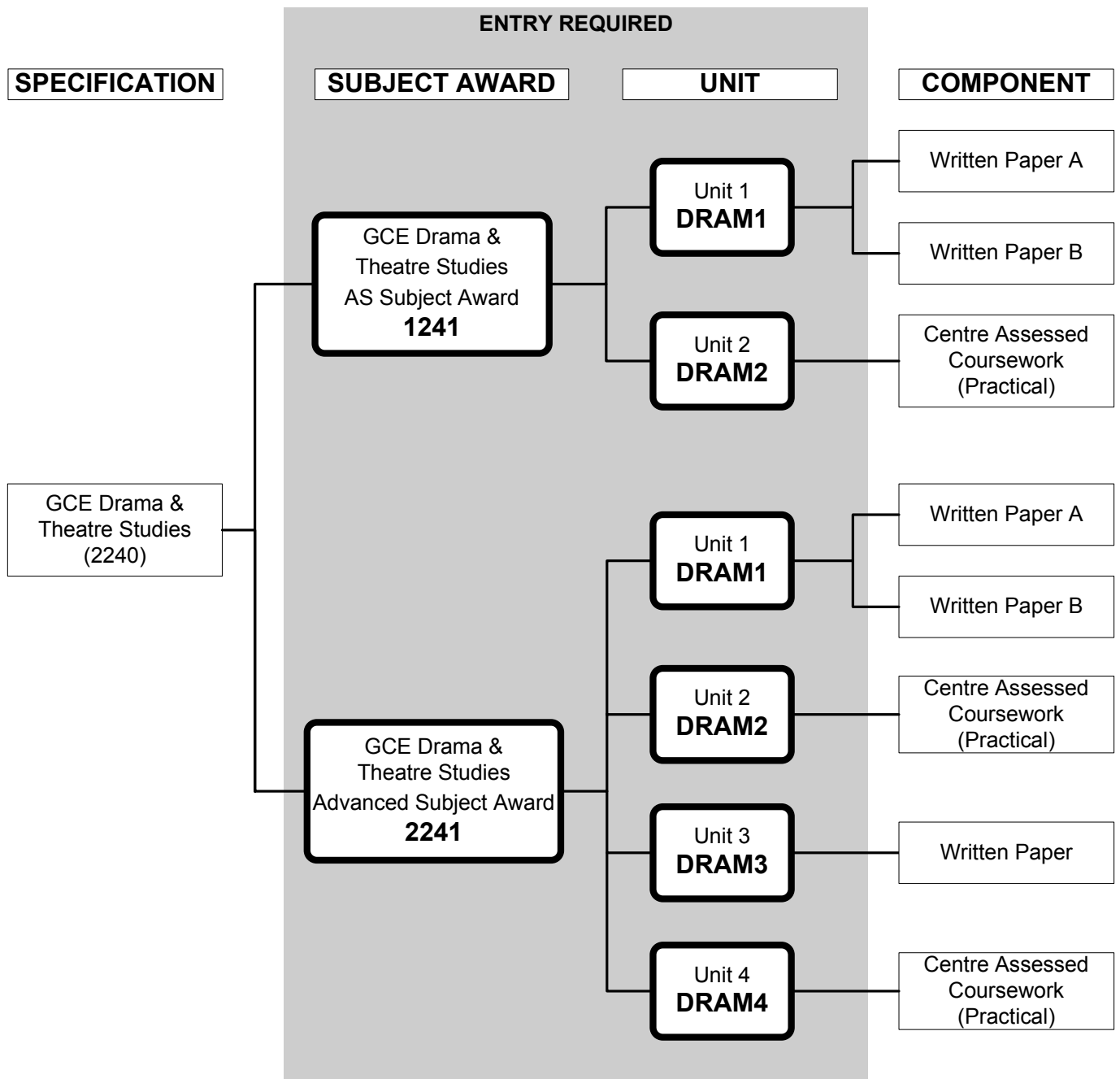

Example of 6-unit award new GCE assessment and entry structure  
GCE Chemistry

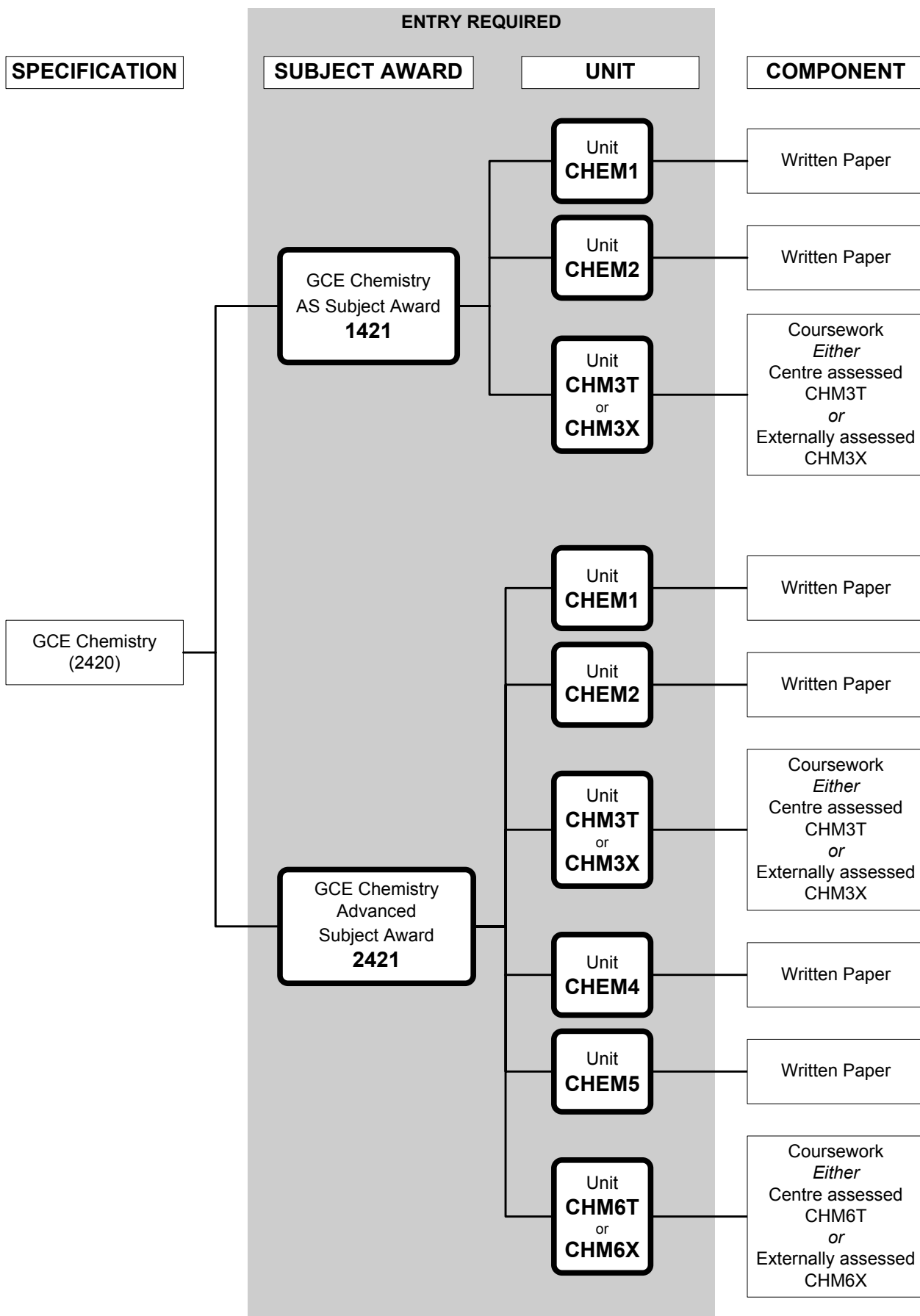

Example of Key Skills Assessment and Entry Structure

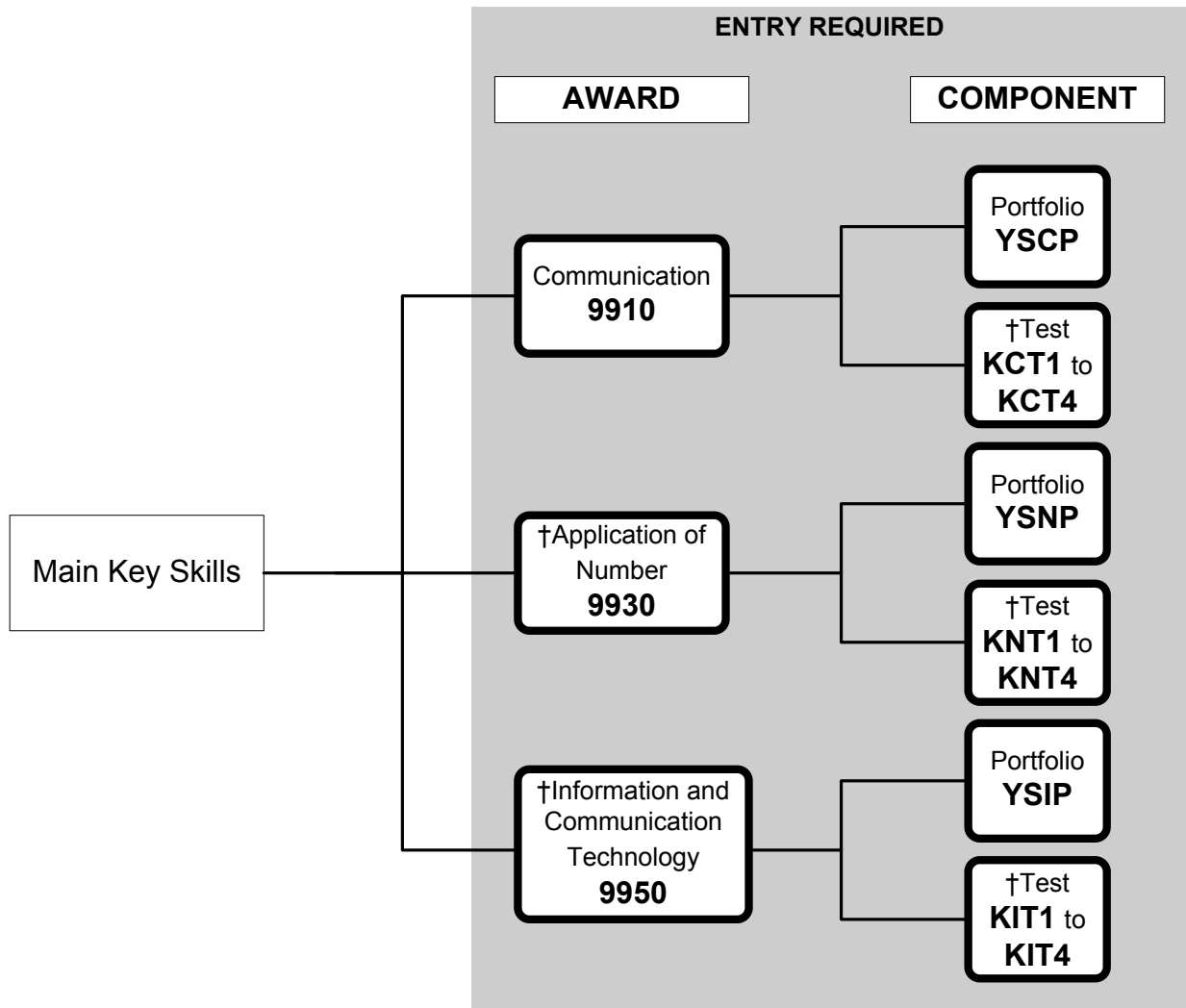

† Exemption from the external tests at levels 1 to 3, from the ICT Unit at levels 1 to 3 and the Application of Number Unit at level 3 can be claimed using the proxy entry codes given in Appendix C. See paragraphs 4.10 to 4.19 for further details of Key Skills proxy claims.

## GCE (including GCE in Applied Subjects) Entry Requirements

4.6 For GCE (including GCE in Applied Subjects) a separate entry is required for

- each unit
- aggregation (optional) of unit results to give an overall AS subject award (single or double for GCE in Applied subjects)
- aggregation of unit results to give an overall Advanced level subject award (single or double for GCE in Applied subjects)
- aggregation of unit results to give an overall Advanced GCE with Additional Subsidiary GCE (additional) level subject award (9 unit award for GCE in Applied subjects).

Unit codes comprise letters and numbers: 4 characters for continuing specifications, 5 characters for new specifications; award codes comprise four numbers<sup>1</sup>. Subject award codes for continuing GCE specifications commence with a '5' for AS and '6' for Advanced; subject awards for new specifications commence with '1' for AS and '2' for Advanced)

For example, a candidate taking an AS Chemistry award (new specification) might wish to sit Unit 1 in January 2010, Units 2 and 3 in June 2010, and claim for the subject award in June 2010. Entries would have to be made for every item in the following list.

	<b>Entry Code</b>	
January 2010	CHEM1	Chemistry Unit 1
June 2010	CHEM2	Chemistry Unit 2
	CHM3T	Chemistry Unit 3, centre assessed coursework option
	1421	AS Chemistry award

**Note:** Candidates who enter for an Advanced award and who wish also to receive an AS award in the subject (either because they have not previously taken an AS award, or because they have retaken AS units and wish to improve a previous AS award) must make an entry for the AS award as well as the Advanced award.

---

<sup>1</sup> Four numbers plus an identifying letter for GCE Art and Design awards.

## Key Skills, Wider Key Skills and Basic Skills Tests

4.7 For the **main Key Skills** (Communication, Application of Number, Information and Communication Technology), a separate entry is required for

- each component (test or portfolio) of each Skill
- aggregation of the test and portfolio results to give a Key Skill Certificate.

For **Basic Skills Tests**, an entry is required for each test at the appropriate level.

4.8 For the three **Wider Key Skills** qualifications (Improving Own Learning and Performance, Problem Solving and Working With Others), only portfolios (no tests) are involved and an entry is required for each unit. Full details of the Wider Key Skills Entry Codes are given in Appendix A. These units are free standing and cannot be included in a Key Skills unit award. The qualification status will be achieved through an enhanced assessment of the portfolio and does not involve the addition of another assessment component.

### Key Skills for Welsh Centres

4.9 The single portfolio component assessment is available only for centres in Wales in the January, March and June 2010 Key Skills assessment series. Complete details of the Key Skills for Welsh centres Entry Codes are given in Appendix A.

### Claims for Exemption from Key Skills Tests or Units – Proxy Claims

- 4.10 To ensure that candidates who have taken GCSE, GCE (including GCE in Applied Subjects), GNVQ or qualifications in English, Gaeilge, General Studies, Welsh, Mathematics and ICT are not involved in unnecessary double assessment when seeking their Key Skills qualifications, the Regulatory Authorities have agreed that certain awards in these subjects can be used to claim exemption from external tests at levels 3, 2 or 1, or the whole Unit at levels 3, 2 or 1 for ICT, and at level 3 for Application of Number only. Full details of these exemptions are given in Appendix B together with the Key Skills Proxy Entry Codes in Appendix C.
- 4.11 Please refer to the QCDA Website ([www.qcda.gov.uk](http://www.qcda.gov.uk)) for the current, definitive list, or contact AQA's Key Skills department via e-mail on [keyskills@aqa.org.uk](mailto:keyskills@aqa.org.uk) for further assistance.
- 4.12 To claim exemptions candidates must be entered for proxies using the proxy entry codes given in Appendix C. There is a fee payable for claiming proxy qualifications, as detailed in the *Entry Fees and other charges 2009/10* booklet.
- 4.13 In the June Key Skills series only, centres will be allowed to claim potential proxies relating to GCE (including GCE in Applied Subjects) awards which have not yet been taken, **provided that the candidate has been entered for the GCE award with AQA in the current (June) series**. It is **not** possible to claim June GCSE qualifications as proxies in the same June. It is essential that candidates claiming current AQA awards as proxies:
- use the proxy entry code given in the table in Appendix C to show the candidate has a 'concurrent AQA entry';
  - use the same UCI for their entries in the Key Skills series and the GCE series (otherwise it will not be possible to match candidates to transfer the results from the GCE series to the Key Skills series).
- 4.14 Entries to claim proxies may be made in the January, March or June Key Skills series. It is not necessary to claim a Key Skill Certificate or a Key Skills qualification that uses the proxy at the same time at which the proxy is claimed.

Once the proxy **has** been claimed, it can be used in a future series. However, proxies must both be **claimed within three years** from the date the qualification on which it is based was awarded, and used in a Key Skills qualification **within three years** from the date the qualification on which it is based was awarded.

- 4.15 When proxy entries have been received, centres will be sent *Key Skills Proxy Details* sheets listing all the candidates entered for each proxy code. Centres will be required to complete these forms to show for each candidate
- the award level (GCE AS/A, VCE, GNVQ, GCSE Full Course, GCSE Short Course, etc)
  - grade awarded
  - subject
  - awarding body
  - date of award (month and year)
  - centre number and candidate number(s) under which the proxy qualification was taken
- 4.16 The Head of the Centre will be asked to sign a declaration that the relevant results slips or certificates have been inspected and must accept responsibility for the accuracy of the details provided. Checks will be made on the accuracy and authenticity of claims for proxies.
- 4.17 The details of proxy claims accepted by AQA will be reported to centres on results slips in the same way that other Key Skills component and Key Skills awards are reported. Centres will be able to enquire within the normal period for enquiries about results if they are not satisfied that a proxy claim has been accurately recorded.
- 4.18 When an entry is made for a Key Skill Certificate, the same entry codes are to be used whether or not a proxy will contribute to the award.
- 4.19 For example, a **Key Skills** candidate might enter as follows

	<b>Entry Code</b>
November 2009	KCT2 Communication Test, Level 2
January 2010	YSCP Communication Portfolio
	9910 Communication Award
March 2010	YSNP Application of Number Portfolio
	KNX2 Application of Number Test Proxy, Level 2
	YSIP Information and Communication Technology Portfolio
	9930 Application of Number Award
June 2010	KIX1 Information and Communication Technology Test Proxy, Level 1
	9950 Information and Communication Technology Award
	YSPS Problem Solving Unit

## Free-Standing Mathematics Qualifications Entry Requirements

- 4.20 For Free-Standing Mathematics Qualifications, a separate entry is required for each unit (qualification) the student wishes to sit.

## Extended Project Qualification (AQA-City & Guilds)

- 4.21 For the Extended Project Qualification, an entry is required only for the qualification.

## Stages in the Entries Procedure

### Centre Approval

- 4.22 Entries can only be accepted from centres that are approved by AQA. Centres that are not approved by AQA (centres which have not previously entered for any examinations with AQA) should request a JCQ *Application for Approval as a Centre for General Qualifications* form, and submit the completed form to AQA's Guildford office as soon as possible.
- 4.23 Full details of entry to AQA examinations and tests for the 2009-2010 academic year are given in the booklet *Entry Procedures and Codes: All Series 2009-2010*, which was sent to all approved centres in September 2009. A brief summary of those procedures is given below.

### Intention to Enter

- 4.24 In June each year AQA provides an *Intention to Enter* booklet, for all Examination Series within the next academic year, to those centres not registered on e-AQA. This booklet allows centres to inform AQA if they will have entries for a particular examination series and to indicate the entry method to be used. Those centres that are registered on e-AQA should normally submit this information via the AQA Website and will only receive a booklet on request. An entry pack (including entry forms if appropriate to the method of entry indicated) will then be provided at least four weeks before the entry closing date. Centres making entries online via e-AQA or via EDI will not receive a separate pack. Centres making entries via EDI are expected to download basedata from the AQA Website.

### Estimated Entries

- 4.25 *Estimated Entries* booklets are provided in June for the Autumn/Winter series and in September for the following Spring/Summer series. Centres are requested to indicate the likely number of entries for individual units. Those centres that are registered on e-AQA should normally submit this information via the AQA Website and will only receive the booklets on request. On the basis of this information, coursework/portfolio advisers and moderators are allocated to centres, record forms and preliminary materials are despatched and teachers are invited to meetings. The information also assists AQA in determining the numbers of question papers to be printed and the numbers of examiners required.

### Method of Entry

- 4.26 Entries may be made by **EDI**, **online via e-AQA**, on **Disks**, or on **Entry Forms** prior to the closing date for entry. For any particular series, only one of the above entry methods may be used. Please see paragraph 6.2 regarding the non-EDI surcharge applied to those main entries not made by EDI or online via e-AQA. Detailed information relating to making entries is shown in the booklet *Entry Procedures and Codes: All Series 2009-2010*.

### Entry Amendments

- 4.27 Entry amendments may be submitted to enter additional candidates or to amend the entries of existing candidates once the main entry submission has been made. Additional fees are charged for entries received after the last date for entry, as given in the AQA document *Entry Fees and other charges 2009/10*.

Amendments to candidates' entries must be received by AQA no later than 14 days before the publication of results for the appropriate series.

## e-AQA

4.28 e-AQA is a secure section of our Website. e-AQA allows authorised staff within your centre to communicate directly with AQA and will offer access to an increasing number of features as the area is developed.

4.29 e-AQA offers two roles for staff at centres:

- the *centre administrator* – who is responsible for registering the centre for e-AQA and managing access for colleagues
- *centre users* – colleagues whose access has been set up by the *centre administrator*.

4.30 e-AQA currently enables you to:

- change details within your personal profile
- for centre administrators, register additional centre users and control their access rights within e-AQA
- view your centre's entries
- view your centre's results
- view Enhanced Results Analysis
- view recent examination materials, including Controlled Assessment tasks
- submit Enquiries about Results and applications for Access to Scripts
- track the progress of your centre's requests for Post-Results services
- submit Intention to Enter information
- submit Estimated Entries
- make and amend entries
- order modified papers
- apply for Access arrangements for GCE and GCSE qualifications
- apply for Special Consideration for all scheduled AQA and AQA –City & Guilds examinations
- order publications on-line via the e-AQA Shop

4.31 If you require any information about or wish to register for e-AQA services, please contact our e-AQA help desk:

 [e-aqahelpdesk@aqa.org.uk](mailto:e-aqahelpdesk@aqa.org.uk)

 0870 410 1041 Monday to Friday, 08 00 to 17 00.

A voicemail service operates outside these hours: please leave a message and a member of the helpdesk team will contact you as soon as possible.

## 5 Candidate identifiers

### Unique Candidate Identifier (UCI)

- 5.1 The need for a Unique Candidate Identifier (UCI) arrived with the development of modular schemes of assessment where candidates may hold module/unit results over a period of time and may study and take tests at more than one centre.

The 13-character UCI is used by awarding bodies to accumulate all the results achieved by a candidate over that period. This enables the subject award to be calculated by totalling the uniform marks for the individual module/unit results.

#### Allocation and use of the UCI

- 5.2 Each candidate beginning a GCE (including GCE in Applied Subjects), Key Skills/Basic Skills tests or FSMQ course will need to be allocated a 13-character Unique Candidate Identifier (UCI) by the centre unless the candidate already has a UCI, for example, where s/he has previously taken an examination through another centre. The candidate will retain this identifier throughout the course.

Once the UCI has been generated it must be used for all specifications entered with AQA or any of the other Awarding Bodies, for all examinations and at any examination centre. Each candidate must have only **one** UCI.

The centre will need to generate the UCI in accordance with the rules that are given below. AQA's Entries staff will provide any help needed in understanding the UCI. AQA will also calculate the check character which will be included in the UCI when the UCI is first allocated, where this is not supplied by the centre.

The UCI will be used for the following purposes:

- entries and results for individual units;
- entries and results for subject awards;
- certificates.

It will be essential for candidates moving from one centre to another to know their UCI, particularly if they are transferring part-way through courses (see paragraph 12.5). The UCI will be quoted on results documentation.

#### How the Unique Candidate Identifier is First Generated

- 5.3 The UCI is generated from information provided by the centre and is built up according to the following rules.

There are 13 characters in the UCI which comprise

the centre number	(positions 1-5)
the board identifier	(position 6)
the <b>academic</b> year of registration	(positions 7-8)
the candidate serial number	(positions 9-12)
the check character	(position 13)

Character	1 2 3 4 5	6	7 8	9 10 11 12	13
Explanation	Centre number	Board Identifier	<b>Academic</b> year of registration	Candidate serial number	Check character

The centre number is **the number of the centre where the candidate took his/her first unit**. Candidates moving to different centres partway through their courses will **retain their original Unique Candidate Identifiers**.

The Board Identifier is usually zero (0).

The year of registration is **the academic year in which the candidate enters for the first unit**. For candidates in the academic year 2009/2010, it will be '09'. For candidates in 2010/2011 it will be '10'.

The candidate serial number is under the control of the centre. It must be in the range 0001 to 9999 and for any year of registration there must be no duplicates. In subsequent years, when new candidates are entered with a new year of registration, serial numbers may be repeated. The candidate serial number element within the UCI will normally be the same as the candidate number used for any linear examinations, but there is no specific requirement that it should be.

The check character will automatically be generated by most software packages. It is useful as a means of validation to check that no mistakes have been made in providing the other characters in the identifier. A full explanation of the algorithm used to generate the check character is given in the *Entry Procedures and Codes: All Series 2009-2010* booklet.

Example of a Unique Candidate Identifier

87425	0	09	2453	B
-------	---	----	------	---

## Unique Learner Number (ULN)

- 5.4 The Unique Learner Number (ULN) is a number that has been introduced to allow individual learners to be uniquely identified and it is compulsory for all learners taking the Diploma. The Diploma qualification is made up of different constituent qualifications that can be taken at different times and with different awarding bodies; The ULN enables these different component results to be aggregated by QCDA's Diploma Aggregation Service so that an overall Diploma result can be awarded.
- 5.5 The ULN is mandatory for the following AQA qualifications:
- Diploma Principal Learning
  - Functional Skills
  - Entries for any qualification that will be used towards a Diploma award.

## 6 Fees

### Entry Fee

- 6.1 Details of the entry fees for the 2009-2010 examinations were notified to centres in September 2009 in the booklet *Entry Fees and other charges 2009/10*.

### Entries made on the *Entry Form*, on Disk, on the *Entry Amendments Form* or in Writing

- 6.2 AQA now receives about 99% of its entries submitted electronically through Electronic Data Interchange (EDI) services and e-AQA.

We appreciate that some centres either do not wish to use EDI or e-AQA or cannot do so. We will therefore continue to offer the possibility of making entries on *Entry Form* or on disk, but will make a surcharge on entries from centres that indicate on their *Intention to Enter* form that they will not be making any entries by EDI or e-AQA in the coming year.

### Late Entry Fee

- 6.3 Unless indicated otherwise in the AQA *Entry Fees and other charges 2009/10*, an additional fee will be charged for each entry of a **new candidate** received after the closing date for the receipt of entries as given in Section 2 and as shown in the table in paragraph 6.9. Details of the Late Entry fees were notified in the booklet *Entry Fees and other charges 2009/10*.

### Very Late Entry Fee

- 6.4 An additional fee, will be charged for each entry of a **new candidate** received after the dates given in the table in paragraph 6.10. Details of the Very Late Entry fees were notified in the booklet *Entry Fees and other charges 2009/10*.

### Amendment Fee

- 6.5 An additional fee, will be charged for each amendment or addition to the entries of existing candidates received after the dates given in the table in paragraph 6.10. Details of the Amendment fees were notified in the booklet *Entry Fees and other charges 2009/10*.

The amendment fee is payable for

- the addition of each new entry for a candidate already entered
- an amendment of an existing entry from one specification to another and
- a change of entry from one unit, module, option/tier or component to another within the same specification

### Withdrawal of Entries

- 6.6 If you withdraw a candidate from one or more entries by the dates given in the table in paragraph 6.10, your centre will receive a refund of entry fees paid to that date.
- 6.7 We do not show the results of withdrawn candidates on the broadsheet of results; the candidates will receive no results for the entries from which they have been withdrawn. Their names will not appear on any lists of candidates produced after the withdrawal has been processed.



Please note that AQA cannot withdraw candidates/entries any later than a fortnight before the publication of results for the appropriate series.

### Partial Refunds on Medical Grounds

- 6.8 After the dates given in column 5 of the table in paragraph 6.10, AQA will consider a partial refund of fees for candidates who are required to withdraw from their examination(s) on medical grounds.

Any request for a partial refund of fees must be accompanied by satisfactory supporting medical evidence. Applications for a partial refund must be submitted to AQA no later than 14 days after the last examination in the appropriate series.

## Payment of Fees

6.9 AQA will send you an invoice once an Entry or Entry Amendments submission has been processed. Fees are due within 30 days of the date of the invoice.

## Dates for Very Late Entry Fees, Amendment Fees and Withdrawals

6.10 Unless indicated otherwise in the *AQA Entry Fees and other charges 2009/10*, the Very Late Entry Fee and Amendment Fee will apply after the dates shown in the table below.

No refunds will be granted for withdrawals of entry made after these dates, unless on medical grounds (see paragraph 6.8).

Series & Year Code	Series Title	Examinations in Series	Late Entry Fees apply after	Very Late Entry Fees & Amendment Fees apply & no refund for withdrawals after
AK09	October 2009 Series AK	Key Skills October Tests Basic Skills Tests	<b>7 SEPTEMBER 2009</b>	<b>21 SEPTEMBER 2009</b>
BK09	November 2009 Series BK	Key Skills November Tests Basic Skills Tests	<b>21 SEPTEMBER 2009</b>	<b>21 OCTOBER 2009</b>
1A10	January 2010 Series 1A	GCE (including GCE in Applied Subjects), FSMQ	<b>21 OCTOBER 2009</b>	<b>15 DECEMBER 2009</b>
1K10	January 2010 Series 1K	Key Skills January Tests Basic Skills Tests	<b>9 NOVEMBER 2009</b>	<b>30 NOVEMBER 2009</b>
3K10	March 2010 Series 3K	Key Skills March Tests Basic Skills Tests	<b>11 JANUARY 2010</b>	<b>8 FEBRUARY 2010</b>
5K10	May 2010 Series 5K	Key Skills May Tests Basic Skills Tests	<b>21 MARCH 2010</b>	<b>21 APRIL 2010</b>
6A10	June 2010 Series 6A	GCE (including GCE in Applied Subjects), Extended Project and FSMQ	<b>21 MARCH 2010</b>	<b>21 APRIL 2010</b>
6K10	June 2010 Series 6K	Key Skills June Tests Basic Skills Tests	<b>31 MARCH 2010</b>	<b>26 APRIL 2010</b>

## 7 Conduct of examinations and externally-assessed assignments

- 7.1 The most recent version of the JCQ *Instructions for Conducting Examinations* applies to the conduct of GCE (including GCE in Applied Subjects) and FSMQ examinations. The additional instructions below should be read in conjunction with certain paragraphs of the *Instructions for Conducting Examinations*.

### Timetable Variations

- 7.2 A timetable of specific dates is used for all examinations which **must** be held on the date and in the session specified. The published starting time of all morning examinations is 9.00 a.m, and the starting time of all afternoon examinations is 1.30 p.m. These are UK times (either GMT or BST as appropriate) current on the examination date, so centres outside the UK must adjust their local starting times to begin at the same time as UK centres.
- 7.3 The JCQ Awarding Bodies allow centres within the United Kingdom to start examinations earlier than or later than the published starting time for the session, without obtaining permission beforehand. However, in order to maintain the security of the examination all candidates must start question papers scheduled for a morning session no earlier than 8.30 a.m. and by 9.30 a.m. and for an afternoon session no earlier than 1.00 p.m. and by 2.00 p.m., unless they are involved in an arrangement to deal with a timetable clash. All arrangements for the invigilation of candidates and the security of question papers detailed in the JCQ *Instructions for Conducting Examinations* must be observed.

Any centre outside the UK wishing to vary the starting time of their examinations from the UK published starting time 9.00 am and 1.30 pm (either GMT or BST as appropriate) to take into account different time zones must obtain permission for this change. Please submit details of proposed changes using the *Overseas timetable declaration for centres outside the United Kingdom* form. You must send such requests by 16th October for the relevant academic year.

- 7.4 Candidates who take an examination later than the UK published starting time must be kept under the direct supervision of centre staff from 30 minutes after the UK published starting time for the paper concerned until the time when those candidates begin their examination.

Candidates who take an examination earlier than the UK published starting time must remain under the supervision arranged by the Head of the Centre until one hour after the UK published starting time for that examination. Additionally, centres must ensure that question papers used by those candidates are kept under secure conditions until one hour after the UK published starting time for that examination. In the case of examinations of less than one hour duration, candidates must be supervised and question papers kept secure until the normal finishing time of the examination.

If some candidates are allowed to take an examination on a later day than other candidates at your centre, all copies of the question paper used on the earlier day must be sealed in an envelope and returned to secure storage until all candidates at your centre have taken that examination.

- 7.5 Candidates may take an examination for more than one unit in a session. Breaks supervised under examination conditions are permitted between examinations at the discretion of the centre. Centres may decide the order of unit examinations, **provided that the security of the examination is maintained throughout**. Centres may hold more than one unit examination at the same time during an examination session. Special care must be taken if a particular examination is taken by different candidates at different times during the session.

It is essential that, where the centre has more than one unit timetabled for the same sessions and opts for a later start for some candidates, **continuous supervision of ALL candidates in the session takes place from 9.30 am or 2.00 pm**.

### Calculators

- 7.6 Full details on the use of calculators are given in Section 3 of the JCQ *Instructions for Conducting Examinations*.

## Accommodation

7.7 Examinations may be taken in teaching rooms, laboratories or workshops, provided that the requirements laid down in Section 5 of the JCQ *Instructions for Conducting Examinations* are met.

## Conduct of Examinations

7.8 All examinations **must** be conducted in accordance with the following sections of the JCQ *Instructions for Conducting Examinations*.

- Section 6 Invigilation arrangements
- Section 7 Identifying candidates
- Section 8 The people present
- Section 9 Question papers, stationery, materials and other equipment
- Section 10 Starting the examination
- Section 11 Supervising the candidates
- Section 12 Candidates who arrive late

## Completing the Attendance Record

7.9 An *Attendance Record* is provided by AQA for each examination showing the names of all candidates entered for that examination. The correct record must be used for each examination taken in the session. If the name of a candidate who is present for the examination does not appear on the record, the candidate's name and number should be written by the invigilator after the last name on the record. If the additional candidate is not already entered, the Head of the Centre or Examinations Officer must submit an entry amendment to AQA as soon as possible.

## Leaving the Examination Room

7.10 No candidate should leave the examination room (except in an emergency) until one hour after the official starting time for the session (i.e. until 10.00 am or 2.30 pm). Candidates who are allowed to leave the examination room temporarily must be accompanied by a member of staff.

## Collection of Scripts and Objective Test Answer Sheets

7.11 Scripts for each unit must be collected separately for despatch to the appropriate examiner, together with the *Attendance Record*. In the case of candidates who were absent for an Objective Test paper, the absence box (only) on the answer sheet must be completed by the invigilator. **All** answer sheets, including those of candidates who were absent, should be despatched to AQA's Guildford office together with the *Attendance Record* using the strengthened envelope provided. As AQA may request the return of used objective test question booklets in connection with any queries that might arise, they must be retained in a safe or secure cupboard until the last date for Enquiries about Results for the appropriate examination series.

## Preliminary material

7.12 Any preliminary material that is required will be sent to centres by 1 November for the January series and by March/April for the June series. The preliminary material must only be used on or after the prescribed date and where this material is confidential it must be stored in accordance with Section 1 of the JCQ *Instructions for Conducting Examinations*.

## Key Skills

7.13 Key Skills Tests at Levels 1 and 2 and Application of Number and Communication at Levels 3 and 4 are scheduled for a specific day. Centres may choose an appropriate starting time for their candidates within the specified day and may repeat the test as necessary for large cohorts.

7.14 At Levels 3 and 4 for Information and Communication Technology the three day assessment window allows greater flexibility, but centres are strongly advised to schedule the tests as early as possible within this period. Question papers and scripts must be stored securely until all candidates have completed the test. Centres are required to schedule specified dates and times within the assessment window for the test to be taken. The schedule must be available in the centre and given to AQA on request. At the end of the last scheduled

session for a test, all the scripts for that test must be sent immediately to the appropriate examiner, together with the *Attendance Record*.

- 7.15 Centres should be aware that a new set of ICT Level 3 and 4 data files for 2009/10 will be placed on the QCDA Website ([www.qcda.gov.uk](http://www.qcda.gov.uk)) for downloading at the start of the academic year (October). AQA reminds centres that candidates must not be given prior knowledge of which data files are to be used in any of the tests. Centres can download all the data files from the QCDA Website and make them available to candidates, in read-only form, as early as possible in the course in preparation for the tests.
- 7.16 Candidates who are absent may sit the test on another of the centre's scheduled sessions for that test. If the planned test sessions have been completed, but the candidate returns before the end of the three day assessment window, the candidate may be allowed to take the test under normal supervised test conditions. Such cases must be notified to AQA in advance of the test being taken so that the centre can be advised of the arrangements for the despatch of the candidate's script.

## 8 Internal assessment

### Coursework/Portfolio Advisers

- 8.1 Coursework/Portfolio Advisers will provide guidance and support to teachers relating to coursework/portfolio units/components. Centres will be informed of the Adviser for each specification being offered, according to the information provided in the Estimated Entries booklet (see paragraph 4.25) or via e-AQA (see paragraphs 4.28 to 4.31).

### Meetings for Teachers

- 8.2 AQA arranges annual standardising meetings, which are usually held in the Autumn Term. The meetings provide guidance on the development of appropriate coursework tasks and accurate and consistent application of the coursework marking criteria as detailed in the specifications. Attendance at these meetings is mandatory for the following categories of centre only:
- Those entering candidates for the new specifications
  - Those where problems were identified with the nature of the coursework tasks set
  - Those where there were problems with the interpretation of the specification requirements
  - Those where a significant adjustment has been made to a centre's marks in the previous year's examination.

Any other centre wishing to send a representative to a coursework standardising meeting (e.g. where there has been a change of teacher or a need for continuing professional development) should write to the relevant subject administration team, with the exception of GCE Art and Design subjects and GCE Applied Art and Design, whose assessment scheme involves 100% teacher assessment and where **all** centres are invited to attend a coursework standardising meeting, subject to availability.

### Internal Standardisation

- 8.3 Each centre is required to standardise the assessments across different teachers and teaching groups to ensure that all candidates at the centre have been judged against the same standards. If two or more teachers are involved, one teacher must be designated as responsible for internal standardisation. The *Centre Declaration Sheet* must be completed to confirm that the marking has been standardised. A copy is available in the specification appendices.
- 8.4 For **GCE in Applied Subjects**, the centre should also ensure that the assessments of **all** units (for a given specification at a given level) have been internally standardised **together** (i.e. all marked to the same general standard).
- 8.5 An accreditation scheme for centres offering the **GCE in Applied Subjects** has been introduced. Where accreditation is offered following the moderation of AS or A2 work submitted for the 2009 examinations, the programme leader (the teacher responsible for internal standardisation for the subject) will be accredited at that level, provided that they remain in that post in the following examination series. Accredited centres will not need to submit coursework samples for that subject and level routinely during the period of accreditation, but should be aware that they will still be subject to random sampling arrangements. If accreditation is not offered following the June series, details of the alternative methods available and the arrangements to apply for these will be sent to centres in autumn 2009.
- 8.6 In **Key Skills**, internal standardisation must cover a given level of a given Skill: for example, all level 2 assessments in Communication must be standardised (across teaching groups). It is helpful if, in addition, centres ensure that the assessments for a Skill are consistent across levels.
- 8.7 In **FSMQ**, the centre should ensure that the assessments of **all** units at a given level have been internally standardised **together**.
- 8.8 For **GCE Art and Design**, all units for a given endorsement (e.g. Fine Art) and at a given level (AS or A2) must be internally standardised **together**.

8.9 For **GCE Applied Art and Design** the following units must be internally standardised together:

- Units 1 and 2
- Units 11 and 12

### Centre Consortium Arrangements for GCE Coursework and Extended Project Qualification Assessment

(Note: Separate arrangements have been developed for Gateway approved consortia delivery of Diploma Principal Learning)

- 8.10 When candidates are entered for AQA examinations from several centres, but are taught together for a particular subject, it is possible for all candidates in the teaching group to be treated as a single population for the purposes of moderation of any centre-assessed component by following the instructions shown below. Please ensure that all appropriate members of staff at your centre are aware of this facility.
- 8.11 The entries of candidates involved in consortium arrangements must be made through the centre at which the candidates are enrolled.
- 8.12 The centres concerned must nominate a consortium co-ordinator who undertakes to liaise with AQA on behalf of all centres in the consortium. The co-ordinator of the consortium must request Centre Consortium Arrangements using form *JCQ/CCA*, which can be found on the JCQ Website at [www.jcq.org.uk](http://www.jcq.org.uk), in order that such arrangements may be put in place.

Where there are different co-ordinators for different specifications, a separate form *JCQ/CCA* is required for each specification.

- 8.13 Completed forms must be returned to the Principal Manager, Processing (Examining), AQA, Stag Hill House, Guildford, GU2 7XJ, by **31 October 2009** for January/March 2009 Series and by **31 January 2010** for the May/June 2010 Series.

### Authentication of Candidates' Work

- 8.14 Candidates' work for assessment must be undertaken under conditions which allow the teacher to supervise the work and enable it to be authenticated. The candidate and teacher are required to sign declarations on the *Candidate Record Form*, confirming that the work submitted for assessment is the candidate's own.

**Any work submitted which has not been authenticated by both the teacher and the candidate will receive a mark of zero.**

### Record Forms

- 8.15 *Centre Declaration Sheets* and *Candidate Record Forms* for all specifications will be circulated to all AQA centres in September/October 2009 for the January 2010 examinations, and January/February 2010 for the June 2010 examinations. Numbers of forms included in this despatch will be based on the centre's estimates for the forthcoming series. Record forms are also on the AQA Website, so that centres can print further copies if required at [www.aqa.org.uk/admin/p\\_course\\_crf\\_2010.php](http://www.aqa.org.uk/admin/p_course_crf_2010.php)

### Last Dates for the Submission of Marks/Assessments or Levels

- 8.16 The latest dates by which centres should submit their marks/assessments or levels to AQA and to the moderator are shown in the table below.

	November	January	March	June
<b>Extended Project Qualification (AQA-City &amp; Guilds)</b>	5 November	-	-	15 May
<b>AS/A GCE</b>	-	10 January	-	15 May (main deadline) 31 May (later deadline)†
<b>Key Skills</b>	-	10 January	10 March	31 May
<b>FSMQ</b>	-	10 January	-	15 May

†For GCE Art & Design, GCE Applied Art & Design, GCE Dance and GCE Drama and Theatre Studies.

### Submission of Marks (GCE/GCE in Applied Subjects/Extended Project/FSMQ) or Levels (Key Skills)

- 8.17 Centres should submit marks (GCE/GCE in Applied Subjects/Extended Project/FSMQ) or levels (Key Skills) on pre-printed multi-part forms (listed below), which are sent to centres 2-3 weeks before the deadline dates. Centres should use the *GCE Centre Mark Form* for GCE in Applied Subjects, Extended Project and FSMQ.

*GCE Centre Mark Form*

*GCE Supplementary Centre Mark Form*

*Key Skills Key Skills Form*

Alternatively, marks may be submitted via EDI.

### Sample for Moderation Purposes

- 8.18 The top copy of the *Centre Mark Sheet* or *Key Skills Form* should be sent to the Guildford Office. Copies 2 and 3 should be sent to the moderator. A record of the coursework marks should always be retained at the centre in case of a query.

Further details of the process of submitting marks and sampling can be found in the *Examination Officers Coursework Administration (CAW/EO/INST)* and *Instructions to Teachers for Submitting Marks and Samples (CAW/INST)*. Both of these documents are available from the AQA Website at [www.aqa.org.uk/admin/p\\_course.php](http://www.aqa.org.uk/admin/p_course.php).

### Outcome of Moderation

- 8.19 Centres will be provided with candidates' final marks for internally-assessed units/components when the results are issued. Written feedback will also be given, providing advice from the moderator.

## 9 Estimated grades

- 9.1 Estimated grades must be submitted for all GCE (including GCE in Applied Subjects) externally-assessed units. Estimated grades for internally-assessed units are **only** collected for new units or where the assessment criteria have changed. Estimated grades for subject awards are not required. The estimated grade for a candidate should be the teacher's judgement of the grade which the candidate is likely to gain in the unit assessment.
- 9.2 The submission of reliable estimated grades is of importance to individual candidates and to AQA. Centres should regard the submission of these as an important contribution to the examining process and try to ensure that they are realistic and indicate the typical performance level for each of their candidates. They should not be based on instances of unusual performance, nor on effort rather than attainment.
- 9.3 Estimated grades are used by AQA for the following purposes:
- to identify cases where additional reviews of candidates' work should be carried out before the publication of results;
  - to respond to requests for special consideration submitted by centres on behalf of candidates who have taken an examination when ill, or who have missed part of an examination because of circumstances beyond their control (see Section 12);
  - to inform Grade Awarding Committees of centres' judgements on the overall standard of the entry for a particular examination.
- 9.4 When marking a candidate's work, the examiners will take no account of the centre's estimated grades. Examiners award marks on the basis of the work presented by the candidates. Each grade awarded will reflect the quality of the work irrespective of the estimated grade, unless a request for special consideration has been received and processed.
- 9.5 Estimated grades must be submitted by 10 January for the January series and 15 May for the June series. They may be submitted by EDI, or on *Estimated Grade Forms* provided by AQA. Separate instructions will be provided.

## 10 Aggregation and grading

### Uniform Mark Scales (UMS)

- 10.1 In a modular scheme of assessment, each unit is assessed once or more each year over a period of years. Some units are compulsory but others are optional. In order to ensure fairness for all candidates, the marks of all units must be standardised to ensure that no candidate is penalised (or advantaged) by taking a slightly more (or less) demanding test than the other tests set on the same unit, or by the choice of optional units.
- 10.2 This standardisation is achieved by converting “raw” unit marks into uniform marks. The **uniform mark scales (UMS)** which are used for all GCE (including GCE in Applied Subjects) have been agreed by the regulatory authorities and the Awarding Bodies. A comprehensive explanation of Uniform Mark Scales is given in the booklet *Uniform Marks in GCE, GCSE and Functional Skills exams and points in the Diploma*, which is available on the AQA Website at [www.aqa.org.uk/over/stat\\_pdf/UNIFORMMARKS-LEAFLET.PDF](http://www.aqa.org.uk/over/stat_pdf/UNIFORMMARKS-LEAFLET.PDF). This booklet is updated twice a year (August and March) to take account of any new or amended qualifications.
- 10.3 In order to convert the ‘raw’ marks on each unit into uniform marks, the grade boundary marks for each unit are first determined by an awarding committee of senior examiners and moderators, following the grade awarding procedures set out in the *GCSE and GCE Code of Practice*. The boundary marks for each grade are then scaled on to the UMS equivalent mark. Unit results are reported in terms of uniform marks. The unit grade equivalence is also shown.

### GCE AS/Advanced Grading

#### Units

- 10.4 The maximum uniform mark available for each unit depends on the weighting of the unit as a percentage of the total Advanced assessment.
- 10.5 The table below shows the uniform mark equivalencies at each grade [for units in specifications with a final resit and certification opportunity in January 2010](#). The table includes all the unit weightings that occur in AQA outgoing specifications.

Grade	UMS marks for unit weighting				
	15%	16.7%	17.5%	20%	50%
Max UMS	90	100	105	120	300
A	72	80	84	96	240
B	63	70	74	84	210
C	54	60	63	72	180
D	45	50	53	60	150
E	36	40	42	48	120

10.6 [Continuing six-unit specifications in GCE mathematics subjects](#) (Mathematics, Pure Mathematics, Further Mathematics and Statistics) will continue to be available until further notice. The table below shows the uniform mark equivalences at each grade for the units in these specifications.

Grade	% of max UMS	UMS marks for each unit
Max UMS		100
A	80	80
B	70	70
C	60	60
D	50	50
E	40	40

10.7 For the [new GCE specifications](#) (first AS certification was in 2009 and first Advanced certification is in June 2010), the maximum uniform mark for a subject award depends on the number of units (see tables below). This is an agreement between all the awarding bodies. The tables below show the uniform mark equivalences at each grade for units in six-unit, four-unit and two-unit specifications.

[Six-unit specifications](#) (Sciences and Music)

	Grade boundaries in terms of uniform marks according to weighting of unit					
<b>Weighting as % of total AS assessment</b>	<b>20%</b>	<b>30%</b>	<b>33.3%</b>	<b>35%</b>	<b>40%</b>	<b>46.7%</b>
<b>Weighting as % of total Advanced assessment</b>	<b>10%</b>	<b>15%</b>	<b>16.7%</b>	<b>17.5%</b>	<b>20%</b>	<b>23.3%</b>
Max UMS	60	90	100	105	120	140
A	48	72	80	84	96	112
B	42	63	70	74	84	98
C	36	54	60	63	72	84
D	30	45	50	53	60	70
E	24	36	40	42	48	56

Four-unit specifications (most subjects)

	Grade boundaries in terms of uniform marks according to weighting of unit				
<b>Weighting as % of total AS assessment</b>	<b>30%</b>	<b>40%</b>	<b>50%</b>	<b>60%</b>	<b>70%</b>
<b>Weighting as % of total Advanced assessment</b>	<b>15%</b>	<b>20%</b>	<b>25%</b>	<b>30%</b>	<b>35%</b>
Max UMS	60	80	100	120	140
A	48	64	80	96	112
B	42	56	70	84	98
C	36	48	60	72	84
D	30	40	50	60	70
E	24	32	40	48	56

Two-unit specifications (certain Modern Foreign Languages)

	Grade boundaries in terms of uniform marks according to weighting of unit
<b>Weighting as % of total AS assessment</b>	<b>100%</b>
<b>Weighting as % of total Advanced assessment</b>	<b>50%</b>
Max UMS	100
A	80
B	70
C	60
D	50
E	40

## Subject Awards

- 10.8 Unit results on the uniform mark scale will be totalled to give Advanced Subsidiary or Advanced subject awards, which will be reported in terms of grades A-E (A\*-E for Advanced awards in and after June 2010). Candidates who do not achieve grades A-E will be reported as U (Unclassified).
- 10.9 For specifications which are [for final certification in January 2010](#), also for [new six-unit specifications](#) (sciences and Music) and for [continuing specifications in GCE mathematics subjects](#) (which will continue to be available until further notice), the maximum uniform mark is 300 for Advanced Subsidiary awards and 600 for Advanced awards. The uniform marks required for each grade are shown in the table below.

Grade	AS Subject Award (Maximum UMS = 300)	A Level Subject Award (Maximum UMS = 600)
A*	See paragraph 10.10	
A	240	480
B	210	420
C	180	360
D	150	300
E	120	240

- 10.10 For new Advanced six-unit GCE specifications, an A\* will be awarded where a grade A has been achieved and the candidate has also obtained a minimum total of 270 uniform marks for the A2 units.

To be awarded an A\* in Mathematics, candidates will need to achieve a grade A on the full A level qualification and 90% of the maximum uniform mark on the aggregate of MPC3 and MPC4.

To be awarded an A\* in Pure Mathematics, candidates will need to achieve grade A on the full A level qualification and 90% of the maximum uniform mark on the aggregate of all three A2 units.

To be awarded an A\* in Further Mathematics, candidates will need to achieve grade A on the full A level qualification and 90% of the maximum uniform mark on the aggregate of the best three of the A2 units which contributed towards Further Mathematics.

To be awarded an A\* in Statistics, candidates will need to achieve a grade A on the full A level qualification and 90% of the maximum uniform mark on the A2 units.

- 10.11 For [new four-unit specifications](#) (most subjects), the maximum uniform mark is 200 for Advanced Subsidiary awards and 400 for Advanced awards. The uniform marks required for each grade are shown in the table below.

Grade	AS Subject Award (Maximum UMS = 200)	A level Subject Award (Maximum UMS = 400)
A*	See paragraph 10.12	
A	160	320
B	140	280
C	120	240
D	100	200
E	80	160

- 10.12 For new Advanced four-unit GCE specifications, an A\* will be awarded where a grade A has been achieved and the candidate has also obtained a minimum total of 180 uniform marks for the A2 units.
- 10.13 For **new two-unit specifications** (certain modern foreign languages), the maximum uniform mark is 100 for Advanced Subsidiary awards and 200 for Advanced awards. The uniform marks required for each grade are shown in the table below.

Grade	AS Subject Award (Maximum UMS = 100)	A level Subject Award (Maximum UMS = 200)
A*	See paragraph 10.14	
A	80	160
B	70	140
C	60	120
D	50	100
E	40	80

- 10.14 For new Advanced two-unit GCE specifications, an A\* will be awarded where a grade A has been achieved and the candidate has also obtained a minimum total of 90 uniform marks for the A2 unit.

## GCE in Applied Subjects AS/Advanced Grading

### Units

- 10.15 The maximum UMS mark available for each unit in an Applied GCE Subject unit is 100. The UMS mark equivalences at each unit grade boundary are shown below.

Grade	UMS marks (max 100)
A	80
B	70
C	60
D	50
E	40

### Subject Awards

- 10.16 Unit results on the uniform mark scale will be totalled to give subject awards for GCE in Applied Subjects.
- 10.17 The Advanced Subsidiary Single Award qualification will be graded on a five-grade scale: A, B, C, D and E. Candidates who fail to reach the minimum standard for grade E will be recorded as U (unclassified) and will not receive a qualification certificate.
- 10.18 The Advanced Single Award qualification will be graded on a six grade scale: A\*, A, B, C, D and E (A\* is available in and after June 2010).

An A\* will be awarded where a grade A has been achieved and the candidate has also obtained a minimum total of 270 uniform marks for the A2 units. Candidates who fail to reach the minimum standard for grade E will be recorded as U and will not receive a qualification certificate.

10.19 The Advanced Subsidiary Double Award qualification will be graded on a nine-grade scale: AA, AB, BB, BC, CC, CD, DD, DE and EE. Candidates who fail to reach the minimum standard for grade EE will be recorded as U (unclassified) and will not receive a qualification certificate. The pair of grades will be reported on the basis of all six units and not two separate sets of three units.

10.20 The Advanced with Advanced Subsidiary (additional) qualification will be graded on a ten-grade scale: A\*A, AA, AB, BB, BC, CC, CD, DD, DE, EE (A\*A is available in and after June 2010).

An A\*A will be awarded where a grade AA has been achieved and the candidate has also obtained a minimum total of 270 uniform marks for the three A2 units. Candidates who fail to reach the minimum standard for EE will be recorded as U (unclassified) and will not receive a qualification certificate.

10.21 The Advanced Double Award qualification will be graded on an eleven-grade scale: A\*A\*, A\*A, AA, AB, BB, BC, CC, CD, DD, DE and EE (A\*A\* and A\*A are available in and after June 2010).

An A\*A\* will be awarded where a grade AA has been achieved and the candidate has also obtained a minimum total of 540 uniform marks for the six A2 units.

An A\*A will be awarded where a grade AA has been achieved and the candidate has also obtained a minimum total of 270 uniform marks for the three best A2 units.

Candidates who fail to reach the minimum standard for grade EE will be recorded as U (unclassified) and will not receive a qualification certificate. The pair of grades will be reported on the basis of all twelve units and not two separate sets of six units.

10.22 Where the unit results permit, a candidate will be able to claim an award for an appropriate subset of units. For example, a candidate who is Unclassified for Advanced Double Award may have done well enough in the appropriate units to receive a graded result for Advanced Single Award. An entry must be made for such an award if it has not been made already – the award will not be issued automatically.

10.23 The minimum UMS marks required for subject awards for GCE in Applied Subjects are shown in the tables below.

#### Single Subject Award

Grade	AS Single Subject Award (three-unit) (Maximum UMS = 300)	Advanced Single Subject Award (six-unit) (Maximum UMS = 600)
A*		See paragraph 10.18
A	240	480
B	210	420
C	180	360
D	150	300
E	120	240

### Double Subject Award

Grade	AS Double Subject Award (six-unit) (Maximum UMS = 600)	Advanced Double Subject Award (twelve-unit) (Maximum UMS = 1200)
A*A*		See paragraph 10.21
A*A		See paragraph 10.21
AA	480	960
AB	450	900
BB	420	840
BC	390	780
CC	360	720
CD	330	660
DD	300	600
DE	270	540
EE	240	480

### Advanced with Advanced Subsidiary (Additional) Subject Award

Grade	Advanced with Advanced Subsidiary (Additional) Subject Award (nine-unit) (Maximum UMS = 900)
A*A	See paragraph 10.20
AA	720
AB	675
BB	630
BC	585
CC	540
CD	495
DD	450
DE	405
EE	360

## GCE (including GCE in Applied Subjects) Entry, Aggregation and Certification Rules

- 10.24 There is no restriction on the number of attempts that may be made at any unit before the subject award is entered. The best of **all** of the available scores for each unit will be used when calculating the subject award except when aggregating AS and A level awards in GCE Mathematics specifications.
- 10.25 Certification of A level Mathematics and AS Further Mathematics requires nine different units (six units for A level Mathematics and three different units for AS Further Mathematics), even if certification of AS Further Mathematics is in a later series and a unit has been re-taken. Similarly certification of A level Mathematics and A level Further Mathematics requires twelve different units.
- AS Further Mathematics cannot be certificated unless AS level Mathematics or A level Mathematics has been, or is being concurrently certificated.
- A level Further Mathematics cannot be certificated unless A level Mathematics has been, or is being concurrently certificated.
- Candidates wishing to enter AS or A level Further mathematics, but not AS/A level Mathematics, with AQA must provide AQA with evidence that AS/A level Mathematics has been certificated or is being concurrently certificated through another awarding body. At the same time they must provide AQA with evidence of the units they are using/have used for AS/A level Mathematics.
- 10.26 For GCE Mathematics subjects AQA will initially generate the best grade for candidates using the unit results available. For a candidate entered for both Mathematics and Further Mathematics, the best grade for Mathematics will be generated first. Units will then be re-distributed across subject titles as necessary to give the best possible total uniform mark(s) without changing the subject grade(s). For a candidate who has taken an extra unit or units (e.g. a candidate entered for Mathematics who has taken seven units), this procedure ensures that the best results are used.
- Re-entering for a qualification in GCE Mathematics subjects releases the units previously used in certifying that qualification. For example, for a candidate who previously certificated A level Mathematics and now wishes to certificate A level Further Mathematics (having taken a further six appropriate units), only the results of the six new units will be available if the candidate enters for Further Mathematics only. Re-entering Mathematics as well as entering Further Mathematics allows all twelve units to be used for aggregation and gives the candidate the best possible grade combination (with the best grade for Mathematics generated first)
- Further details regarding aggregation in GCE Mathematics subjects are available on the AQA and JCQ websites.
- 10.27 When a candidate has taken more than the required number of units, AQA will calculate the best grade available.
- 10.28 Unit results which have been used to count towards a GCE or GCE in Applied Subjects AS award will remain available for inclusion in a GCE or GCE in Applied Subjects Advanced award in the future. In the case of GCE in Applied Subjects, unit results which have been used to count towards a Single Award AS or Advanced grade also remain available for inclusion in a Double Award AS, Advanced GCE with Additional Subsidiary GCE (additional) or Advanced grade.
- Please note that unit results that have been used to count towards a previous award cannot be re-used, at the same level, for an award in a specification with a different subject title (except in Mathematics subjects when awards are re-entered). For example, a candidate who uses unit results for an award in AS Biology cannot re-use those results when claiming AS Biology (Human), although the unit results can be re-used when claiming either Advanced Biology or Advanced Biology (Human).
- 10.29 Further details are given in the *Entry, Aggregation and Certification Procedures and Rules* (issued in September 2009).
- 10.30 A candidate who enters for a unit, but is absent from the unit, will be treated as having a score of zero uniform marks for the purposes of aggregation to a subject award. For example, a candidate who has entered for an Advanced award and has results or absences for all of the six units required will be awarded an Advanced result based on the scores available (See also Section 13).

## Carrying Forward Coursework or Portfolio Marks

- 10.31 (a) Where coursework forms **part of a GCE unit** (as in the case of some GCE Biology, Chemistry, Mathematics, Statistics, Physics A and Sport and PE units), the coursework mark may be carried forward to another examination series whether the unit has or has not been included in an AS or Advanced award. The previous 12 month restriction on carrying forward coursework marks was removed in June 2004 and there is now no limit on the number of occasions on which the marks can be re-used, or on the period of time since the original result, provided that it is within the lifetime of the specification.
- (b) The results of written and practical examination components in units made up of two or more components may **not** be carried forward. Candidates who wish to re-take a unit made up of coursework and a written examination must re-take the written examination. Candidates who wish to re-take a unit made up of a written examination and a practical examination must re-take both components.
- (c) Following the withdrawal of the decline procedure after Summer 2007 it is now possible for candidates, entering for subject awards in January 2010 or thereafter, to re-use any units (including units which consist entirely of coursework) which have already been used towards a previous subject award.

## Key Skills Grading/Aggregation

- 10.32 The result for each Key Skills component will be reported as level 1-4, or as U (Unclassified). Candidates who have results or have made entries for the internal component (portfolio) and the external component (test) in one of the three main Key Skills may enter for a Certificate in that Skill. If the candidate has achieved the same level in the portfolio and the test, that level will be reported as the level of the award. If the candidate has different levels in the portfolio and the test, the **lower** of the two levels will be reported as the level of the award. If a candidate has not achieved at least level 1 in both components, the award will be reported as U (Unclassified).

Candidates who subsequently improve their results in one of the components may enter for a new Certificate. The best component results will be used to determine the level of the award.

- 10.33 The Wider Key Skills (Working with Others, Improving Own Learning and Performance, Problem Solving) are free-standing units, assessed by a single portfolio component only. Results will be reported as levels 1-4 or U (Unclassified).

## FSMQ and AS Use of Mathematics Grading/Aggregation

- 10.34 The result of each Free-Standing Mathematics Qualification (unit) will be reported on the grade scale A-E. Candidates who do not achieve grades A-E will be reported as U (Unclassified).
- 10.35 Candidates who wish to re-take a unit may carry forward their moderated coursework portfolio mark to another examination series; the former 12 month restriction on carrying forward coursework marks was removed in June 2004. Candidates may re-take a complete unit, which comprises a coursework portfolio component and a test component, as many times as they wish.
- 10.36 The FSMQ Advanced units can be included in the AQA GCE AS qualification in Use of Mathematics (subject award code 5351) which is offered in June 2010. The specification comprises two FSMQ units and an AS unit (UOM4):
- FSMQ 6991 Working with Algebraic and Graphical Techniques
  - *either* FSMQ 6990 Using and Applying Statistics  
*or* FSMQ 6992 Modelling with Calculus  
*or* FSMQ 6994 Using and Applying Decision Mathematics
  - AS Unit UOM4 Applying Mathematics

Results for these units are reported as UMS marks, with a maximum uniform mark of 100 for each unit (see the table in paragraph 10.4). Results for the FSMQ units are also reported on the grade scale A-E.

## Transfer of Credit

- 10.37 Where a candidate completes a GCE AS or GCE in Applied Subjects AS Single Award qualification on one specification and has to move to another examination centre where it is not possible to prepare the candidate for A2 or AS Double Award units in the same specification, it may be possible, subject to confirmation by the 'receiving' awarding body, to combine the UMS result for the AS or AS Single Award (but not for individual units) with the results of the A2 or AS Double Award units from a different specification.

Similarly this also applies to those candidates who have done a GCE in Applied Subjects Advanced Single Award and wish to continue to the Advanced Double Award with another awarding body. It may be possible, subject to confirmation by the 'receiving' awarding body, to combine the UMS result for the Advanced Single Award (but not for individual units) with the results of the Advanced Double Award units from a different specification.

For new specification GCE subjects, transfer of credit will be offered in the same way. However, transfer between continuing AS and new specification A2 subjects will **not** be allowed.

The Awarding Bodies have established procedures to deal with such cases. Further information is available from the JCQ Website (at [www.jcq.org.uk](http://www.jcq.org.uk)) in the document *Entry, Aggregation and Certification Procedures and Rules* (issued in September 2009).

This provision will not be possible where there is undue overlap between the AS content in the first specification and A2 content in the second.

Where AQA is the 'receiving' awarding body, centres should contact the Candidate Support Department at their assigned AQA office.

- 10.38 The JCQ document *Entry, Aggregation and Certification Procedures and Rules* effective from 1 September 2009 to 21 August 2010 provides further instructions and guidance regarding Transfer of Credit, and is available from the JCQ Website at [www.jcq.org.uk](http://www.jcq.org.uk).

# 11 Late Awards

## Late Awards

- 11.1 A candidate who has completed **all** the units required for a subject award but who has not entered for an award in the current examination series may:
- either enter for an award without charge after the issue of unit results, provided the request is received within the four week period immediately following the publication of results. After the closing date for Enquiries about Results (EARs), requests for late awards will be considered on an exceptional basis only, but those agreed will incur a fee for each late award to be aggregated.
- or **enter for a subject award in a later examination series, provided the specification is still available.**

## Cashing-in – Options

- 11.2 The following information gives an example of a student who wishes to finish his/her qualifications after taking three units, and of a student who intends to progress to a six-unit award (N.B. the following also applies to the AS and Advanced single awards for a GCE in an Applied Subject):

### Options and actions for the student intending to finish the qualification

This information applies to a student who has completed the units for a GCE AS or Advanced qualification and who has no intention of proceeding to a further award.

- If the student is satisfied with the aggregated grade and cashing in was applied for at the time the entry was made, no further action is necessary.
- If cashing in was not applied for at the time of entry, it can be applied for retrospectively after the issue of results and by the published date for late subject awards (20 September 2009 for June 2009 examination series or 12 April 2010 for January 2010 examination series or 20 September 2010 for June 2010 examination series).
- If the student is not satisfied with the aggregated grade and wishes to improve it, one or more of the units may be re-sat and certification requested again in a future examination series. Where a unit consists of more than one option, the candidate may take a new optional unit. The best result for each unit will count towards the new award.

### Options and actions for the student intending to take the qualification further

This information applies to a student who has completed the units for a GCE AS or Advanced qualification and who wishes to take that qualification further.

- The student can proceed to a further qualification whether or not the first award is cashed in or aggregated. Individual units may be re-sat at a future series and count towards the further qualification.
- If the student is satisfied with the aggregated grade and cashing in was applied for at the time the entry was made, no further action is necessary.
- If cashing in was not applied for at the time of entry, it can be applied for retrospectively after the issue of results and by the published date for late subject awards (20 September 2009 for June 2009 examination series or 12 April 2010 for January 2010 examination series or 20 September 2010 for June 2010 examination series).
- If the student applied to cash in the result, the grade for that qualification can be improved in January or June 2010 by entering for and taking the assessment for at least one contributing unit. Where a unit consists of more than one option, the candidate may take a new optional unit. The student's best result for each unit will count towards a new award.

- 11.3 Similar rules will apply for new GCE specifications.

## 12 Special circumstances

### Irregularities and Late Arrivals

- 12.1 Centres must inform their assigned AQA office of any irregularity occurring in a unit and of any candidate who arrives late for an examination.

### Access Arrangements

- 12.2 For GCE (including GCE in Applied Subjects), FSMQ and Key Skills examinations, please refer to the most recent version of the Inter-Board document *Access Arrangements and Special Consideration Regulations and Guidance Relating to Candidates who are Eligible for Adjustments in Examinations*.
- 12.3 Requests for Access Arrangements must be made to the assigned AQA office as early as possible and preferably at the time when the candidate embarks on the course of study. Applications for special versions of unit tests for candidates with sensory impairment must be received by AQA by the following dates:

Examination Series held in:	Access Arrangement	Closing Date
November/December/January	Modified Papers	30 September
November	All other access arrangements (not modified papers)	30 September
December/January	All other access arrangements (not modified papers)	31 October
February/March/April	All arrangements including modified papers	30 November
May/June	Modified Papers	31 January
May/June	All other arrangements (not modified papers)	21 February

### Special Consideration

- 12.4 The normal arrangements for Special Consideration will apply to each unit. Requests for special consideration should be submitted to the assigned AQA office as soon as possible after the unit test. Requests for special consideration received after the results are published will not normally be considered.

### Candidates who change centres

- 12.5 Centres must ensure that candidates who change centres, and who have already taken some units, retain their original Unique Candidate Identifier in order to ensure the correct recording of unit results.

## 13 Results

13.1 The following results documents will be provided, as appropriate for your centre's entries.

- Candidates' individual statements of provisional results showing
  - for GCE subjects (including GCE in Applied Subjects)
    - the subject grade and UMS total mark for all subject awards entered in the current series, together with the details and UMS marks and grade equivalence of the units included in the award
    - the UMS mark and the unit grade equivalence for each unit entered in the current series
    - the UMS mark and the unit grade equivalence for all units taken at the centre in previous series
  - the grade (A-E) for FSMQ
  - the level (1-4) for Key Skills units and components entered in the current and in previous series
  - the level (1-2) for Basic Skills subject awards
  - where the candidate has not met the minimum standard to be awarded a grade or level, a U (Ungraded) will be shown
  - X will be shown where the candidate was absent for some or all of the unit or award
- Centre broadsheets of subject results showing awards taken in the current series
- Centre Results Statistics, showing the numbers of candidates obtaining each of the relevant grades (or Unclassified) for subject awards in the current series
- Centre Cumulative Record of candidates' Unit Results for the current and for previous series for each specification
- Centre Component Marks Report for all components taken in the current series (including final (moderated) marks for coursework/portfolio components).

13.2 Results will also be available by EDI and on-line via e-AQA.

13.3 Certificates will be issued where candidates have attained a grade or level for the subject award. The certificate states the grade for each subject and states the series that the award was entered. Results of U (Unclassified) will not be certificated.

## 14 Enquiries about results

- 14.1 The services available for Enquiries about Results include a clerical check, a re-mark and re-moderation of coursework/portfolios. Services on individual units/components are only available in the series in which the unit/component was taken and within a specified period after the publication of results.
- 14.2 In cases where a result enquiry reveals inaccurate assessment, the original UMS mark (or Key Skills level) for the unit concerned may be confirmed, raised, or lowered. If the unit is included in a GCE (including GCE in Applied Subjects), subject award, the original grade may be confirmed, raised or lowered; however, for re-moderated centre-assessed units with lowered UMS marks, any subject grade *in the current series* is protected.
- 14.3 Further details of Enquiries about Results services will be provided to centres with the results in the JCQ booklet *Post Results Services*. This may be downloaded from the JCQ Website at [www.jcq.org.uk](http://www.jcq.org.uk).

### Access to Scripts

- 14.4 Full details of arrangements for Access to Scripts are given in the JCQ booklet *Post Results Services* and are also available from the AQA Website on the following link, [www.aqa.org.uk/admin/p\\_results.php](http://www.aqa.org.uk/admin/p_results.php).
- 14.5 Centres will be able to request access to candidates' scripts (i.e. work from externally-assessed units) on their behalf. Priority photocopies of GCE (including GCE in Applied Subjects) scripts which are required for the sole purpose of deciding whether or not to request an enquiry about results must be requested within eight days of the publication of results. Photocopies of the scripts will then be received by centres at least ten days before the closing date for Enquiries about Results. A request can also be made for a photocopy of a re-marked script at the time an enquiry about results is made.
- 14.6 Scripts which are required for general interest or to support future learning must be requested no later than two weeks after the closing date for Enquiries about Results. The original scripts will be sent after the closing date for enquiries.
- 14.7 Full details of all Post-Results Services, including Access to Scripts, are given in the JCQ booklet *Post Results Services*, circulated to centres in the Summer Term 2009. Access to Scripts is not available for internally-assessed coursework/portfolio components or units, or for Key Skills (except for Level 3) or Basic Skills Tests.
- 14.8 Centres should make candidates aware of the arrangements for access to scripts before candidates sit their examinations.

## Appendix A: Availability of GCE (including GCE in Applied Subjects), GCE New Specifications, Basic and Key Skills, FSMQ and Extended Project Qualification (AQA-City & Guilds) examinations 2009-2010

### GCE (including GCE In Applied Subjects) Outgoing Advanced (A2) Units January 2010 Final Re-Sit Opportunity

Please refer to Appendix D for information about the withdrawal of Curriculum 2000 Specifications

UNIT	UNIT ENTRY CODE	UNIT TYPE	JAN 2010	JUNE 2010
<b>ACCOUNTING</b>				<b>6121</b>
Unit 5	ACC5	W	✓	-
Unit 6	ACC6	W	✓	-
Unit 7	ACC7	W	✓	-
<b>ARCHAEOLOGY</b>				<b>6011</b>
Unit 4	ACH4	W	✓	-
Unit 5	ACH5	W	✓	-
<b>BENGALI</b>				<b>6636</b>
Unit 2	BEN2	W	✓	-
<b>BIOLOGY/HUMAN BIOLOGY A</b>				
<b>Biology</b>				<b>6411</b>
<b>Human Biology</b>				<b>6413</b>
(Units 5, 6 & 8 Biology, Units 5, 7 & 9 Human Biology)				
Unit 5	BYA5	W	✓	-
Unit 6	BYA6	W	✓	-
Unit 7	BYA7	W	✓	-
Unit 8	BYA8	W&C*	✓	-
Unit 9	BYA9	W&C*	✓	-
<b>BIOLOGY B</b>				<b>6416</b>
Unit 4	BYB4	W	✓	-
Unit 5	BYB5	W&C	✓	-
Unit 6	BYB6	W	✓	-
Unit 7	BYB7	W	✓	-
Unit 8	BYB8	W	✓	-
<b>BUSINESS STUDIES</b>				<b>6131</b>
Unit 4	BUS4	W	✓	-
Unit 5	BU5W	W	✓	-
Unit 5	BU5C	C	✓	-
Unit 6	BUS6	W	✓	-

\* **Units BYA8 and BYA9:** Candidates are not permitted to submit new coursework for the coursework components of Units BYA8 and BYA9. Therefore, these units are available only to candidates who have a previous result for the coursework component, in which case the previous coursework component mark may be carried forward and the written component re-taken.

UNIT	UNIT ENTRY CODE	UNIT TYPE	JAN 2010	JUNE 2010
<b>CHEMISTRY</b>				<b>6421</b>
Unit 4	CHM4	W	✓	-
Unit 5	CHM5	W	✓	-
Unit 6	CH6C	OT&C*	✓	-
Unit 6	CH6P	OT&Pr	✓	-
<b>CLASSICAL CIVILISATION</b>				<b>6021</b>
Unit 4	CIV4	W	✓	-
Unit 5	CIV5	W	✓	-
<b>COMMUNICATION STUDIES</b>				<b>6626</b>
Unit 5	CMS5	W	✓	-
Unit 6	CMS6	W	✓	-
<b>COMPUTING</b>				<b>6511</b>
Unit 4	CPT4	W	✓	-
Unit 5	CPT5	W	✓	-
<b>DANCE</b>				<b>6231</b>
Unit 4	DAN4	Pr	✓	-
Unit 5	DAN5	Pr	✓	-
Unit 6	DAN6	W	✓	-
<b>DESIGN AND TECHNOLOGY: FOOD TECHNOLOGY</b>				<b>6541</b>
Unit 6	FTY6	W	✓	-
<b>DESIGN AND TECHNOLOGY: PRODUCT DESIGN</b>				<b>6551</b>
Unit 6 (3D Design)	PD6D	W	✓	-
Unit 6 (Textiles)	PD6T	W	✓	-
<b>DESIGN AND TECHNOLOGY: SYSTEMS AND CONTROL TECHNOLOGY</b>				<b>6556</b>
Unit 6	SCT6	W	✓	-

\* **Unit CH6C:** Candidates are not permitted to submit new coursework for the coursework component of Unit CH6C. Therefore, this unit is available only to candidates who have a previous result for the coursework component, in which case the previous coursework component mark may be carried forward and the written component re-taken.

UNIT	UNIT ENTRY CODE	UNIT TYPE	JAN 2010	JUNE 2010
<b>DRAMA AND THEATRE STUDIES</b>				<b>6241</b>
Unit 5	DRA5	W	✓	-
Unit 6	DRA6	W	✓	-
<b>ECONOMICS</b>				<b>6141</b>
Unit 4	EC4C	C	✓	-
Unit 4	EC4W	W	✓	-
Unit 5	ECN5	W	✓	-
Unit 6	ECN6	W	✓	-
<b>ELECTRONICS</b>				<b>6431</b>
Unit 4	ELE4	W	✓	-
Unit 5	ELE5	W	✓	-
<b>ENGLISH LANGUAGE A</b>				<b>6701</b>
Unit 4	EA4C	C	✓	-
Unit 4	EA4W	W	✓	-
Unit 5	ENA5	W	✓	-
Unit 6	ENA6	W	✓	-
<b>ENGLISH LANGUAGE B</b>				<b>6706</b>
Unit 4	ENB4	C	✓	-
Unit 5	ENB5	W	✓	-
Unit 6	ENB6	W	✓	-
<b>ENGLISH LANGUAGE AND LITERATURE A</b>				<b>6721</b>
Unit 4	NTA4	W	✓	-
Unit 5	NTA5	W	✓	-
Unit 6	NTA6	W	✓	-
<b>ENGLISH LANGUAGE AND LITERATURE B</b>				<b>6726</b>
Unit 4	NTB4	C	✓	-
Unit 5	NTB5	W	✓	-
Unit 6	NTB6	W	✓	-
<b>ENGLISH LITERATURE A</b>				<b>6741</b>
Unit 4	LTA4	W	✓	-
Unit 5	LA5C	C	✓	-
Unit 5	LA5W	W	✓	-
Unit 6	LTA6	W	✓	-
<b>ENGLISH LITERATURE B</b>				<b>6746</b>
Unit 4	LTB4	C	✓	-
Unit 5	LTB5	W	✓	-
Unit 6	LTB6	W	✓	-
<b>ENVIRONMENTAL SCIENCE</b>				<b>6441</b>
Unit 4	ESC4	W	✓	-
Unit 5	ESC5	W	✓	-
Unit 7	ESC7	W	✓	-
<b>FRENCH</b>				<b>6651</b>
Unit 4	FR04	W	✓	-
Unit 5	FR5W	W	✓	-
Unit 6	FR6T	CO	✓	-

UNIT	UNIT ENTRY CODE	UNIT TYPE	JAN 2010	JUNE 2010
<b>GENERAL STUDIES A</b>				<b>6761</b>
Unit 4 (E)	GA4E	OT&W	✓	-
Unit 4 (F)	GA4F	OT&W	✓	-
Unit 4 (G)	GA4G	OT&W	✓	-
Unit 4 (S)	GA4S	OT&W	✓	-
Unit 5	GSA5	OT&W	✓	-
Unit 6	GSA6	W	✓	-
<b>GENERAL STUDIES B</b>				<b>6766</b>
Unit 4	GB4C	C	✓	-
Unit 4	GB4W	W	✓	-
Unit 5	GSB5	W	✓	-
Unit 6	GSB6	W	✓	-
<b>GEOGRAPHY A</b>				<b>6031</b>
Unit 4	GGA4	W	✓	-
Unit 5	GGA5	W	✓	-
Unit 6	GGA6	C	✓	-
Unit 7	GGA7	W	✓	-
<b>GEOGRAPHY B</b>				<b>6036</b>
Unit 4	GGB4	W	✓	-
Unit 5	GGB5	W	✓	-
Unit 6	GGB6	W	✓	-
Unit 7	GGB7	C	✓	-
<b>GERMAN</b>				<b>6661</b>
Unit 4	GR04	W	✓	-
Unit 5	GR5W	W	✓	-
Unit 6	GR6T	CO	✓	-
<b>GOVERNMENT AND POLITICS</b>				<b>6151</b>
Unit 4	GOV4	W	✓	-
Unit 5	GOV5	W	✓	-
Unit 6	GOV6	W	✓	-
Unit 7	GOV7	W	✓	-
Unit 8	GOV8	W	✓	-

UNIT	UNIT ENTRY CODE	UNIT TYPE	JAN 2010	JUNE 2010
<b>HISTORY</b>				<b>6041</b>
Unit 4 European/World History (Alternatives A-L)				
A	HS4A	W	✓	-
B	HS4B	W	✓	-
C	HS4C	W	✓	-
D	HS4D	W	✓	-
E	HS4E	W	✓	-
F	HS4F	W	✓	-
G	HS4G	W	✓	-
H	HS4H	W	✓	-
J	HS4J	W	✓	-
K	HS4K	W	✓	-
L	HS4L	W	✓	-
Unit 5 British History (Alternatives M-U)				
M	HS5M	W	✓	-
N	HS5N	W	✓	-
O	HS5O	W	✓	-
P	HS5P	W	✓	-
Q	HS5Q	W	✓	-
R	HS5R	W	✓	-
S	HS5S	W	✓	-
T	HS5T	W	✓	-
U	HS5U	W	✓	-
Unit 6 (Alternatives A-U)				
A	HS6A	W	✓	-
B	HS6B	W	✓	-
C	HS6C	W	✓	-
D	HS6D	W	✓	-
E	HS6E	W	✓	-
F	HS6F	W	✓	-
G	HS6G	W	✓	-
H	HS6H	W	✓	-
J	HS6J	W	✓	-
K	HS6K	W	✓	-
L	HS6L	W	✓	-
M	HS6M	W	✓	-
N	HS6N	W	✓	-
O	HS6O	W	✓	-
P	HS6P	W	✓	-
Q	HS6Q	W	✓	-
R	HS6R	W	✓	-
S	HS6S	W	✓	-
T	HS6T	W	✓	-
U	HS6U	W	✓	-
<b>HISTORY OF ART</b>				<b>6251</b>
Unit 5	HOA5	W	✓	-
Unit 6	HOA6	W	✓	-

UNIT	UNIT ENTRY CODE	UNIT TYPE	JAN 2010	JUNE 2010
<b>HOME ECONOMICS</b>				<b>6561</b>
Unit 5	HEC5	CS	✓	-
Unit 6 (F)	HEC6	W	✓	-
Unit 7 (T)	HEC7	W	✓	-
<b>INFORMATION AND COMMUNICATION TECHNOLOGY</b>				<b>6521</b>
Unit 4	ICT4	W	✓	-
Unit 5	ICT5	W	✓	-
Unit 6	ICT6	C	✓	-
<b>LAW</b>				<b>6161</b>
Unit 4	LAW4	W	✓	-
Unit 5	LAW5	W	✓	-
Unit 6	LAW6	W	✓	-
<b>MEDIA STUDIES</b>				<b>6571</b>
Unit 4	MED4	W	✓	-
Unit 5	MED5	C	✓	-
Unit 6	MED6	W	✓	-
<b>MODERN HEBREW</b>				<b>6676</b>
Unit 2	HEB2	W	✓	-
<b>MUSIC</b>				<b>6271</b>
Unit 4	MUS4	W	✓	-
Unit 6	MUS6	Pr	✓	-
<b>PANJABI</b>				<b>6681</b>
Unit 2	PAN2	W	✓	-
<b>PHILOSOPHY</b>				<b>6171</b>
Unit 4	PLY4	W	✓	-
Unit 5	PLY5	W	✓	-
Unit 6	PLY6	S St	✓	-
<b>PHYSICS A</b>				<b>6451</b>
Unit 4	PA04	OT&W	✓	-
Unit 5	PA5C	W&C*	✓	-
Unit 5	PA5P	W&Pr	✓	-
Unit 6	PA6C	W&C*	✓	-
Unit 6	PA6P	W&Pr	✓	-
Unit 7	PA7C	W&C*	✓	-
Unit 7	PA7P	W&Pr	✓	-
Unit 8	PA8C	W&C*	✓	-
Unit 8	PA8P	W&Pr	✓	-
Unit 9	PA9C	W&C*	✓	-
Unit 9	PA9P	W&Pr	✓	-
Unit 10	PA10	W	✓	-

\* **Units PA5C, PA6C, PA7C, PA8C and PA9C:** Candidates are not permitted to submit new coursework for the coursework components of Units PA5C, PA6C, PA7C, PA8C and PA9C. Therefore, these units are available only to candidates who have a previous result for the coursework component, in which case the previous coursework component mark may be carried forward and the written component re-taken.

UNIT	UNIT ENTRY CODE	UNIT TYPE	JAN 2010	JUNE 2010
<b>PHYSICS B</b>				<b>6456</b>
Unit 4	PHB4	W	✓	-
Unit 5	PHB5	W	✓	-
Unit 6	PHB6	Pr	✓	-
<b>POLISH</b>				<b>6686</b>
Unit 2	POL2	W	✓	-
<b>PSYCHOLOGY A</b>				<b>6181</b>
Unit 4	PYA4	W	✓	-
Unit 5	PYA5	W	✓	-
Unit 6	PYA6	C	✓	-
<b>PSYCHOLOGY B</b>				<b>6186</b>
Unit 4	PYB4	W	✓	-
Unit 5	PYB5	W	✓	-
Unit 6	PYB6	C	✓	-
<b>RELIGIOUS STUDIES</b>				<b>6061</b>
Unit 7	RS07	W	✓	-
Unit 8	RS08	W	✓	-
Unit 9	RS09	W	✓	-
Unit 10	RS10	W	✓	-
Unit 11	RS11	W	✓	-
Unit 12	RS12	W	✓	-
<b>SOCIOLOGY</b>				<b>6191</b>
Unit 4	SCY4	W	✓	-
Unit 5	SC5C	C	✓	-
Unit 5	SC5W	W	✓	-
Unit 6	SCY6	W	✓	-
<b>SPANISH</b>				<b>6696</b>
Unit 4	SP04	W	✓	-
Unit 5	SP5W	W	✓	-
Unit 6	SP6T	CO	✓	-
<b>SPORT AND PHYSICAL EDUCATION</b>				<b>6581</b>
Unit 4	PED4	W	✓	-
Unit 5	PED5	W	✓	-

### Unit type

C	Coursework
CO	Oral (Centre-conducted)
CT	Controlled Test
CS	Case Study
E	Externally-Assessed Assignment
ES	Externally-Set Assignment: Centre assessed
OT	Objective Test
P	Portfolio
Pr	Practical
Proj	Project
St	Study
S St	Synoptic Study
VO	Oral (Visiting Examiner)
W	Written Paper

**GCE (including GCE In Applied Subjects)  
NEW and CONTINUING SPECIFICATIONS  
ADVANCED SUBSIDIARY (AS) and ADVANCED (A2)**

UNIT	UNIT ENTRY CODE	UNIT TYPE	JAN 2010	JUNE 2010	JAN 2011	JUNE 2011
<b>ACCOUNTING</b>			<b>1121, 2121</b>			
Unit 1	ACCN1	W	✓	✓	✓	✓
Unit 2	ACCN2	W	✓	✓	✓	✓
Unit 3	ACCN3	W	✓	✓	✓	✓
Unit 4	ACCN4	W	✓	✓	✓	✓
<b>ANTHROPOLOGY (Subject to approval by Ofqual)</b>						
Unit 1	tbc	tbc	-	-	✓	✓
Unit 2	tbc	tbc	-	-	-	✓
<b>ARCHAEOLOGY</b>			<b>1011, 2121</b>			
Unit 1	ARCH1	W	✓	✓	✓	✓
Unit 2	ARCH2	W	-	✓	-	✓
Unit 3	ARCH3	W	-	✓	-	✓
Unit 4	ARCH4	C	-	✓	-	✓
<b>ART AND DESIGN (Art, Craft and Design) 1201A, 2201A</b>						
Unit 1	ARTA1	C	-	✓	-	✓
Unit 2	ARTA2	ES	-	✓	-	✓
Unit 3	ARTA3	C	-	✓	-	✓
Unit 4	ARTA4	ES	-	✓	-	✓
<b>ART AND DESIGN (Fine Art) 1202B, 2202B</b>						
Unit 1	ARTB1	C	-	✓	-	✓
Unit 2	ARTB2	ES	-	✓	-	✓
Unit 3	ARTB3	C	-	✓	-	✓
Unit 4	ARTB4	ES	-	✓	-	✓
<b>ART AND DESIGN (Graphic Communication) 1203C, 2203C</b>						
Unit 1	ARTC1	C	-	✓	-	✓
Unit 2	ARTC2	ES	-	✓	-	✓
Unit 3	ARTC3	C	-	✓	-	✓
Unit 4	ARTC4	ES	-	✓	-	✓
<b>ART AND DESIGN (Textile Design) 1204D, 2204D</b>						
Unit 1	ARTD1	C	-	✓	-	✓
Unit 2	ARTD2	ES	-	✓	-	✓
Unit 3	ARTD3	C	-	✓	-	✓
Unit 4	ARTD4	ES	-	✓	-	✓
<b>ART AND DESIGN (Three Dimensional Design) 1205E, 2205E</b>						
Unit 1	ARTE1	C	-	✓	-	✓
Unit 2	ARTE2	ES	-	✓	-	✓
Unit 3	ARTE3	C	-	✓	-	✓
Unit 4	ARTE4	ES	-	✓	-	✓
<b>ART AND DESIGN (Photography) 1206F, 2206F</b>						
Unit 1	ARTF1	C	-	✓	-	✓
Unit 2	ARTF2	ES	-	✓	-	✓
Unit 3	ARTF3	C	-	✓	-	✓
Unit 4	ARTF4	ES	-	✓	-	✓

UNIT	UNIT ENTRY CODE	UNIT TYPE	JAN 2010	JUNE 2010	JAN 2011	JUNE 2011
<b>APPLIED ART AND DESIGN</b>						
<b>AS Single (3 units)</b>			<b>8511</b>			
<b>AS Double (6 units)</b>			<b>8513</b>			
<b>A Single (6 units)</b>			<b>8516</b>			
<b>AS Additional (9 units)</b>			<b>8517</b>			
<b>A Double (12 units)</b>			<b>8519</b>			
Unit 1	AD01	P	-	✓	-	✓
Unit 2	AD02	P	-	✓	-	✓
Unit 3	AD03	CT	✓	✓	✓	✓
Unit 4	AD04	P	-	✓	-	✓
Unit 5	AD05	CT	✓	✓	✓	✓
Unit 6A	ADA6	P	-	✓	-	✓
Unit 6B	ADB6	P	-	✓	-	✓
Unit 6C	ADC6	P	-	✓	-	✓
Unit 6D	ADD6	P	-	✓	-	✓
Unit 6E	ADE6	P	-	✓	-	✓
Unit 6F	ADF6	P	-	✓	-	✓
Unit 7	AD07	P	-	✓	-	✓
Unit 8	AD08	P	-	✓	-	✓
Unit 9	AD09	CT	✓	✓	✓	✓
Unit 10	AD10	P	-	✓	-	✓
Unit 11A	AA11	P	-	✓	-	✓
Unit 11B	AB11	P	-	✓	-	✓
Unit 11C	AC11	P	-	✓	-	✓
Unit 11D	AD11	P	-	✓	-	✓
Unit 11E	AE11	P	-	✓	-	✓
Unit 11F	AF11	P	-	✓	-	✓
Unit 12A	AA12	P	-	✓	-	✓
Unit 12B	AB12	P	-	✓	-	✓
Unit 12C	AC12	P	-	✓	-	✓
Unit 12D	AD12	P	-	✓	-	✓
Unit 12E	AE12	P	-	✓	-	✓
Unit 12F	AF12	P	-	✓	-	✓
<b>BENGALI</b>			<b>1636, 2636</b>			
Unit 1	BENG1	W	-	✓	-	✓
Unit 2	BENG2	W	-	✓	-	✓
<b>BIOLOGY</b>			<b>1411, 2411</b>			
Unit 1	BIOL1	W	✓	✓	✓	✓
Unit 2	BIOL2	W	✓	✓	✓	✓
Unit 3T	BIO3T	C	-	✓	-	✓
Unit 3X	BIO3X	E	-	✓	-	✓
Unit 4	BIOL4	W	✓	✓	✓	✓
Unit 5	BIOL5	W	-	✓	-	✓
Unit 6T	BIO6T	C	-	✓	-	✓
Unit 6X	BIO6X	E	-	✓	-	✓

UNIT	UNIT ENTRY CODE	UNIT TYPE	JAN 2010	JUNE 2010	JAN 2011	JUNE 2011
<b>APPLIED BUSINESS</b>						
AS Single (3 units)						8611
AS Double (6 units)						8613
A Single (6 units)						8616
AS Additional (9 units)						8617
A Double (12 units)						8619
Unit 1	BS01	P	-	✓	-	✓
Unit 2	BS02	P	-	✓	-	✓
Unit 3	BS03	W	✓	✓	✓	✓
Unit 4	BS04	W	✓	✓	✓	✓
Unit 5	BS05	W	✓	✓	✓	✓
Unit 6	BS06	P	-	✓	-	✓
Unit 7	BS07	P	-	✓	-	✓
Unit 8	BS08	P	-	✓	-	✓
Unit 9	BS09	P	-	✓	-	✓
Unit 10	BS10	P	-	✓	-	✓
Unit 11	BS11	W	✓	✓	✓	✓
Unit 12	BS12	W	✓	✓	✓	✓
Unit 13	BS13	P	-	✓	-	✓
Unit 14	BS14	P	-	✓	-	✓
Unit 15	BS15	W	✓	✓	✓	✓
Unit 16	BS16	P	-	✓	-	✓
<b>BUSINESS STUDIES</b>						1131, 2131
Unit 1	BUSS1	W	✓	✓	✓	✓
Unit 2	BUSS2	W	✓	✓	✓	✓
Unit 3	BUSS3	W	✓	✓	✓	✓
Unit 4	BUSS4	W	✓	✓	✓	✓
<b>CHEMISTRY</b>						1421, 2421
Unit 1	CHEM1	W	✓	✓	✓	✓
Unit 2	CHEM2	W	✓	✓	✓	✓
Unit 3	CHM3T	C	-	✓	-	✓
Unit 3	CHM3X	E	-	✓	-	✓
Unit 4	CHEM4	W	✓	✓	✓	✓
Unit 5	CHEM5	W	✓	✓	✓	✓
Unit 6	CHM6T	C	-	✓	-	✓
Unit 6	CHM6X	E	-	✓	-	✓
<b>CITIZENSHIP STUDIES</b>						1101, 2101
Unit 1	CIST1	W	✓	✓	✓	✓
Unit 2	CIST2	W	✓	✓	✓	✓
Unit 3	CIST3	W	✓	✓	✓	✓
Unit 4	CIST4	W	-	✓	-	✓

UNIT	UNIT ENTRY CODE	UNIT TYPE	JAN 2010	JUNE 2010	JAN 2011	JUNE 2011
<b>CLASSICAL CIVILISATION</b>						1021, 2021
Unit 1A	CIV1A	W	✓	✓	✓	✓
Unit 1B	CIV1B	W	✓	✓	✓	✓
Unit 1C	CIV1C	W	✓	✓	✓	✓
Unit 1D	CIV1D	W	✓	✓	✓	✓
Unit 1E	CIV1E	W	✓	✓	✓	✓
Unit 1F	CIV1F	W	✓	✓	✓	✓
Unit 2A	CIV2A	W	-	✓	-	✓
Unit 2B	CIV2B	W	-	✓	-	✓
Unit 2C	CIV2C	W	-	✓	-	✓
Unit 2D	CIV2D	W	-	✓	-	✓
Unit 2E	CIV2E	W	-	✓	-	✓
Unit 2F	CIV2F	W	-	✓	-	✓
Unit 3	CIV3A	W	-	✓	-	✓
Unit 3B	CIV3B	W	-	✓	-	✓
Unit 3C	CIV3C	W	-	✓	-	✓
Unit 3D	CIV3D	W	-	✓	-	✓
Unit 4A	CIV4A	W	-	✓	-	✓
Unit 4B	CIV4B	W	-	✓	-	✓
Unit 4C	CIV4C	W	-	✓	-	✓
Unit 4D	CIV4D	W	-	✓	-	✓
<b>COMMUNICATION AND CULTURE</b>						1626, 2626
Unit 1	COMM1	W	✓	✓	✓	✓
Unit 2	COMM2	C	-	✓	-	✓
Unit 3	COMM3	W	-	✓	✓	✓
Unit 4	COMM4	C	-	✓	-	✓
<b>COMPUTING</b>						1511, 2511
Unit 1	COMP1	W	-	✓	-	✓
Unit 2	COMP2	W	✓	✓	✓	✓
Unit 3	COMP3	W	-	✓	-	✓
Unit 4	COMP4	C	-	✓	-	✓
<b>CRITICAL THINKING</b>						1771, 2771
Unit 1	CRIT1	W	✓	✓	✓	✓
Unit 2	CRIT2	W	✓	✓	✓	✓
Unit 3	CRIT3	W	-	✓	-	✓
Unit 4	CRIT4	W	-	✓	-	✓
<b>DANCE</b>						1231, 2231
Unit 1	DANC1	W	-	✓	-	✓
Unit 2	DANC2	C	-	✓	-	✓
Unit 3	DANC3	W	-	✓	-	✓
Unit 4	DANC4	Pr	-	✓	-	✓
<b>DESIGN AND TECHNOLOGY: FOOD TECHNOLOGY</b>						1541, 2541
Unit 1	FOOD1	W	✓	✓	✓	✓
Unit 2	FOOD2	C	-	✓	-	✓
Unit 3	FOOD3	W	-	✓	-	✓
Unit 4	FOOD4	C	-	✓	-	✓
<b>DESIGN AND TECHNOLOGY: PRODUCT DESIGN (3-D DESIGN)</b>						1551, 2551
Unit 1	PROD1	W	✓	✓	✓	✓
Unit 2	PROD2	C	-	✓	-	✓
Unit 3	PROD3	W	-	✓	-	✓
Unit 4	PROD4	C	-	✓	-	✓

UNIT	UNIT ENTRY CODE	UNIT TYPE	JAN 2010	JUNE 2010	JAN 2011	JUNE 2011
<b>DESIGN AND TECHNOLOGY: PRODUCT DESIGN (TEXTILES)</b>			<b>1561, 2561</b>			
Unit 1	TEXT1	W	✓	✓	✓	✓
Unit 2	TEXT2	C	-	✓	-	✓
Unit 3	TEXT3	W	-	✓	-	✓
Unit 4	TEXT4	C	-	✓	-	✓
<b>DESIGN AND TECHNOLOGY: SYSTEMS AND CONTROL TECHNOLOGY</b>			<b>1556, 2556</b>			
Unit 1	SYST1	W	-	✓	-	✓
Unit 2	SYST2	C	-	✓	-	✓
Unit 3	SYST3	W	-	✓	-	✓
Unit 4	SYST4	C	-	✓	-	✓
<b>DRAMA AND THEATRE STUDIES</b>			<b>1241, 2241</b>			
Unit 1	DRAM1	W	✓	✓	✓	✓
Unit 2	DRAM2	C	-	✓	-	✓
Unit 3	DRAM3	W	✓	✓	✓	✓
Unit 4	DRAM4	C	-	✓	-	✓
<b>ECONOMICS</b>			<b>1141, 2141</b>			
Unit 1	ECON1	OT&W	✓	✓	✓	✓
Unit 2	ECON2	OT&W	✓	✓	✓	✓
Unit 3	ECON3	W	✓	✓	✓	✓
Unit 4	ECON4	W	✓	✓	✓	✓
<b>ELECTRONICS</b>			<b>1431, 2431</b>			
Unit 1	ELEC1	W	-	✓	-	✓
Unit 2	ELEC2	W	-	✓	-	✓
Unit 3	ELEC3	C	-	✓	-	✓
Unit 4	ELEC4	W	-	✓	-	✓
Unit 5	ELEC5	W	-	✓	-	✓
Unit 6	ELEC6	C	-	✓	-	✓
<b>ENGLISH LANGUAGE A</b>			<b>1701, 2701</b>			
Unit 1	ENGA1	W	✓	✓	✓	✓
Unit 2	ENGA2	C	✓	✓	✓	✓
Unit 3	ENGA3	W	✓	✓	✓	✓
Unit 4	ENGA4	C	✓	✓	✓	✓
<b>ENGLISH LANGUAGE B</b>			<b>1706, 2706</b>			
Unit 1	ENGB1	W	✓	✓	✓	✓
Unit 2	ENGB2	C	✓	✓	✓	✓
Unit 3	ENGB3	W	✓	✓	✓	✓
Unit 4	ENGB4	C	✓	✓	✓	✓
<b>ENGLISH LANGUAGE AND LITERATURE A</b>			<b>1721, 2721</b>			
Unit 1	ELLA1	W	✓	✓	✓	✓
Unit 2	ELLA2	W	✓	✓	✓	✓
Unit 3	ELLA3	W	✓	✓	✓	✓
Unit 4	ELLA4	C	✓	✓	✓	✓
<b>ENGLISH LANGUAGE AND LITERATURE</b>			<b>1726, 2726</b>			
Unit 1	ELLB1	W	✓	✓	✓	✓
Unit 2	ELLB2	C	✓	✓	✓	✓
Unit 3	ELLB3	W	✓	✓	✓	✓
Unit 4	ELLB4	C	✓	✓	✓	✓

UNIT	UNIT ENTRY CODE	UNIT TYPE	JAN 2010	JUNE 2010	JAN 2011	JUNE 2011
<b>ENGLISH LITERATURE A</b>			<b>1741, 2741</b>			
Unit 1A	LTA1A	W	✓	✓	✓	✓
Unit 1B	LTA1B	W	✓	✓	✓	✓
Unit 1C	LTA1C	W	✓	✓	✓	✓
Unit 2	LITA2	C	✓	✓	✓	✓
Unit 3	LITA3	W	✓	✓	✓	✓
Unit 4	LITA4	C	✓	✓	✓	✓
<b>ENGLISH LITERATURE B</b>			<b>1746, 2746</b>			
Unit 1	LITB1	W	✓	✓	✓	✓
Unit 2	LITB2	C	✓	✓	✓	✓
Unit 3	LITB3	W	✓	✓	✓	✓
Unit 4	LITB4	C	✓	✓	✓	✓
<b>ENVIRONMENTAL STUDIES</b>			<b>1441, 2441</b>			
Unit 1	ENVS1	W	✓	✓	✓	✓
Unit 2	ENVS2	W	✓	✓	✓	✓
Unit 3	ENVS3	W	-	✓	-	✓
Unit 4	ENVS4	W	-	✓	-	✓
<b>FRENCH</b>			<b>1651, 2651</b>			
Unit 1	FREN1	W	✓	✓	✓	✓
Unit 2	FRE2T	CO	✓	✓	✓	✓
Unit 2	FRE2V	VO	-	✓	-	✓
Unit 3	FREN3	W	-	✓	-	✓
Unit 4	FRE4T	CO	-	✓	-	✓
Unit 4	FRE4V	VO	-	✓	-	✓
<b>GENERAL STUDIES A</b>			<b>1761, 2761</b>			
Unit 1	GENA1	OT&W	✓	✓	✓	✓
Unit 2	GENA2	OT&W	✓	✓	✓	✓
Unit 3	GENA3	W	✓	✓	✓	✓
Unit 4	GENA4	W	✓	✓	✓	✓
<b>GENERAL STUDIES B</b>			<b>1766, 2766</b>			
Unit 1	GENB1	W	✓	✓	✓	✓
Unit 2	GENB2	W	✓	✓	✓	✓
Unit 3	GENB3	W	✓	✓	✓	✓
Unit 4	GENB4	W	✓	✓	✓	✓
<b>GEOGRAPHY</b>			<b>1031, 2031</b>			
Unit 1	GEOG1	W	✓	✓	✓	✓
Unit 2	GEOG2	W	✓	✓	✓	✓
Unit 3	GEOG3	W	-	✓	✓	✓
Unit 4A	GEO4A	W	✓	✓	✓	✓
Unit 4B	GEO4B	W	✓	✓	✓	✓
<b>GERMAN</b>			<b>1661, 2661</b>			
Unit 1	GERM1	W	✓	✓	✓	✓
Unit 2	GER2T	CO	✓	✓	✓	✓
Unit 2	GER2V	VO	-	✓	-	✓
Unit 3	GERM3	W	-	✓	-	✓
Unit 4T	GER4T	CO	-	✓	-	✓
Unit 4V	GER4V	VO	-	✓	-	✓

UNIT	UNIT ENTRY CODE	UNIT TYPE	JAN 2010	JUNE 2010	JAN 2011	JUNE 2011
<b>GOVERNMENT AND POLITICS</b>					<b>1151, 2151</b>	
Unit 1	GOVP1	W	✓	✓	✓	✓
Unit 2	GOVP2	W	✓	✓	✓	✓
Unit 3A	GOV3A	W	✓	✓	✓	✓
Unit 3B	GOV3B	W	✓	✓	✓	✓
Unit 3C	GOV3C	W	✓	✓	✓	✓
Unit 4A	GOV4A	W	-	✓	-	✓
Unit 4B	GOV4B	W	-	✓	-	✓
Unit 4C	GOV4C	W	-	✓	-	✓
<b>HEALTH AND SOCIAL CARE</b>						
<b>AS Single (3 units)</b>					<b>8621</b>	
<b>AS Double (6 units)</b>					<b>8623</b>	
<b>A Single (6 units)</b>					<b>8626</b>	
<b>AS Additional (9 units)</b>					<b>8627</b>	
<b>A Double (12 units)</b>					<b>8629</b>	
Unit 1	HC01	W	✓	✓	✓	✓
Unit 2	HC02	P	-	✓	-	✓
Unit 3	HC03	P	-	✓	-	✓
Unit 4	HC04	W	✓	✓	✓	✓
Unit 5	HC05	W	✓	✓	✓	✓
Unit 6	HC06	W	✓	✓	✓	✓
Unit 7	HC07	P	-	✓	-	✓
Unit 8	HC08	P	-	✓	-	✓
Unit 9	HC09	P	-	✓	-	✓
Unit 10	HC10	P	-	✓	-	✓
Unit 11	HC11	P	-	✓	-	✓
Unit 12	HC12	W	✓	✓	✓	✓
Unit 13	HC13	W	✓	✓	✓	✓
Unit 14	HC14	W	✓	✓	✓	✓
Unit 15	HC15	W	✓	✓	✓	✓
Unit 16	HC16	P	-	✓	-	✓
Unit 17	HC17	P	-	✓	-	✓
Unit 18	HC18	P	-	✓	-	✓
Unit 19	HC19	P	-	✓	-	✓
Unit 20	HC20	P	-	✓	-	✓
Unit 21	HC21	P	-	✓	-	✓
<b>HISTORY</b>					<b>1041, 2041</b>	
Unit 1 Change and Consolidation (Alternatives A-N)						
A	HIS1A	W	✓	✓	✓	✓
B	HIS1B	W	✓	✓	✓	✓
C	HIS1C	W	✓	✓	✓	✓
D	HIS1D	W	✓	✓	✓	✓
E	HIS1E	W	✓	✓	✓	✓
F	HIS1F	W	✓	✓	✓	✓
G	HIS1G	W	✓	✓	✓	✓
H	HIS1H	W	✓	✓	✓	✓
J	HIS1J	W	✓	✓	✓	✓
K	HIS1K	W	✓	✓	✓	✓
L	HIS1L	W	✓	✓	✓	✓
M	HIS1M	W	✓	✓	✓	✓
N	HIS1N	W	✓	✓	✓	✓

UNIT	UNIT ENTRY CODE	UNIT TYPE	JAN 2010	JUNE 2010	JAN 2011	JUNE 2011
<b>HISTORY <i>continued</i></b>					<b>1041, 2041</b>	
Unit 2 Historical Issues: Periods of Change (Alternatives A-S)						
A	HIS2A	W	✓	✓	✓	✓
B	HIS2B	W	✓	✓	✓	✓
C	HIS2C	W	✓	✓	✓	✓
D	HIS2D	W	✓	✓	✓	✓
E	HIS2E	W	✓	✓	✓	✓
F	HIS2F	W	✓	✓	✓	✓
G	HIS2G	W	✓	✓	✓	✓
H	HIS2H	W	✓	✓	✓	✓
J	HIS2J	W	✓	✓	✓	✓
K	HIS2K	W	✓	✓	✓	✓
L	HIS2L	W	✓	✓	✓	✓
M	HIS2M	W	✓	✓	✓	✓
N	HIS2N	W	✓	✓	✓	✓
O	HIS2O	W	✓	✓	✓	✓
P	HIS2P	W	✓	✓	✓	✓
Q	HIS2Q	W	✓	✓	✓	✓
R	HIS2R	W	✓	✓	✓	✓
S	HIS2S	W	✓	✓	✓	✓
Unit 3 The State and the People (Alternatives A-N)						
A	HIS3A	W	-	✓	-	✓
B	HIS3B	W	-	✓	-	✓
C	HIS3C	W	-	✓	-	✓
D	HIS3D	W	-	✓	-	✓
E	HIS3E	W	-	✓	-	✓
F	HIS3F	W	-	✓	-	✓
G	HIS3G	W	-	✓	-	✓
H	HIS3H	W	-	✓	-	✓
J	HIS3J	W	-	✓	-	✓
K	HIS3K	W	-	✓	-	✓
L	HIS3L	W	-	✓	-	✓
M	HIS3M	W	-	✓	-	✓
N	HIS3N	W	-	✓	-	✓
Unit 4						
Unit 4	HIS4X	C	-	✓	-	✓
<b>HISTORY OF ART</b>					<b>1251, 2251</b>	
Unit 1	HART1	W	-	✓	-	✓
Unit 2	HART2	W	-	✓	-	✓
Unit 3	HART3	W	-	✓	-	✓
Unit 4	HART4	W	-	✓	-	✓
<b>HUMAN BIOLOGY</b>					<b>1406, 2406</b>	
Unit 1	HBIO1	W	✓	✓	✓	✓
Unit 2	HBIO2	W	✓	✓	✓	✓
Unit 3	HBI3T	C	-	✓	-	✓
Unit 3	HBI3X	E	-	✓	-	✓
Unit 4	HBIO4	W	✓	✓	✓	✓
Unit 5	HBIO5	W	-	✓	-	✓
Unit 6	HBI6T	C	-	✓	-	✓
Unit 6	HBI6X	E	-	✓	-	✓

UNIT	UNIT ENTRY CODE	UNIT TYPE	JAN 2010	JUNE 2010	JAN 2011	JUNE 2011
<b>INFORMATION AND COMMUNICATION TECHNOLOGY</b> 1521, 2521						
Unit 1	INFO1	W	✓	✓	✓	✓
Unit 2	INFO2	W	✓	✓	✓	✓
Unit 3	INFO3	W	✓	✓	✓	✓
Unit 4	INFO4	C	✓	✓	✓	✓
<b>APPLIED INFORMATION AND COMMUNICATION TECHNOLOGY</b>						
<b>AS Single (3 units)</b>						<b>8751</b>
<b>AS Double (6 units)</b>						<b>8753</b>
<b>A Single (6 units)</b>						<b>8756</b>
<b>AS Additional (9 units)</b>						<b>8757</b>
<b>A Double (12 units)</b>						<b>8759</b>
Unit 1	IT01	E	✓	✓	✓	✓
Unit 2	IT02	P	-	✓	-	✓
Unit 3	IT03	P	-	✓	-	✓
Unit 4	IT04	P	-	✓	-	✓
Unit 5	IT05	P	-	✓	-	✓
Unit 6	IT06	P	-	✓	-	✓
Unit 7	IT07	P	-	✓	-	✓
Unit 8	IT08	P	-	✓	-	✓
Unit 9	IT09	E	✓	✓	✓	✓
Unit 10	IT10	E	✓	✓	✓	✓
Unit 11	IT11	P	-	✓	-	✓
Unit 12	IT12	P	-	✓	-	✓
Unit 13	IT13	P	-	✓	-	✓
Unit 14	IT14	P	-	✓	-	✓
Unit 15	IT15	P	-	✓	-	✓
<b>LAW</b> 1161, 2161						
Unit 1	LAW01	W	✓	✓	✓	✓
Unit 2	LAW02	W	✓	✓	✓	✓
Unit 3	LAW03	W	✓	✓	✓	✓
Unit 4	LAW04	W	-	✓	-	✓
<b>LEISURE STUDIES</b>						
<b>AS Single (3 units)</b>						<b>8641</b>
<b>AS Double (6 units)</b>						<b>8643</b>
<b>A Single (6 units)</b>						<b>8646</b>
<b>AS Additional (9 units)</b>						<b>8647</b>
<b>A Double (12 units)</b>						<b>8649</b>
Unit 1	LS01	P	-	✓	-	✓
Unit 2	LS02	E	✓	✓	✓	✓
Unit 3	LS03	P	-	✓	-	✓
Unit 4	LS04	W	✓	✓	✓	✓
Unit 5	LS05	P	-	✓	-	✓
Unit 6	LS06	P	-	✓	-	✓
Unit 7	LS07	P	-	✓	-	✓
Unit 8	LS08	P	-	✓	-	✓
Unit 9	LS09	E	✓	✓	✓	✓
Unit 10	LS10	P	-	✓	-	✓
Unit 11	LS11	P	-	✓	-	✓
Unit 12	LS12	W	✓	✓	✓	✓
Unit 13	LS13	P	-	✓	-	✓
Unit 14	LS14	P	-	✓	-	✓

UNIT	UNIT ENTRY CODE	UNIT TYPE	JAN 2010	JUNE 2010	JAN 2011	JUNE 2011
<b>MATHEMATICS</b>						
<b>Mathematics</b>				<b>AS 5361</b>	<b>A 6361</b>	
<b>Pure Mathematics</b>				<b>AS 5366</b>	<b>A 6366</b>	
<b>Further Mathematics</b>				<b>AS 5371</b>	<b>A 6371</b>	
Pure Core 1	MPC1	W	✓	✓	✓	✓
Pure Core 2	MPC2	W	✓	✓	✓	✓
Pure Core 3	MPC3	W	✓	✓	✓	✓
Pure Core 4	MPC4	W	✓	✓	✓	✓
Further Pure 1	MFP1	W	✓	✓	✓	✓
Further Pure 2	MFP2	W	✓	✓	✓	✓
Further Pure 3	MFP3	W	✓	✓	✓	✓
Further Pure 4	MFP4	W	✓	✓	✓	✓
Mechanics 1A	MM1A	W&C	✓	✓	✓	✓
Mechanics 1B	MM1B	W	✓	✓	✓	✓
Mechanics 2B	MM2B	W	✓	✓	✓	✓
Mechanics 3	MM03	W	-	✓	-	✓
Mechanics 4	MM04	W	-	✓	-	✓
Mechanics 5	MM05	W	-	✓	-	✓
Statistics 1A	MS1A	W&C	✓	✓	✓	✓
Statistics 1B	MS1B	W	✓	✓	✓	✓
Statistics 2B	MS2B	W	✓	✓	✓	✓
Statistics 3	MS03	W	-	✓	-	✓
Statistics 4	MS04	W	-	✓	-	✓
Decision 1	MD01	W	✓	✓	✓	✓
Decision 2	MD02	W	✓	✓	✓	✓
<b>MEDIA STUDIES</b> 1571, 2571						
Unit 1	MEST1	W	✓	✓	✓	✓
Unit 2	MEST2	C	✓	✓	✓	✓
Unit 3	MEST3	W	-	✓	✓	✓
Unit 4	MEST4	C	-	✓	✓	✓
<b>MODERN HEBREW</b> 1676, 2676						
Unit 1	MHEB1	W	-	✓	-	✓
Unit 2	MHEB2	W	-	✓	-	✓

UNIT	UNIT ENTRY CODE	UNIT TYPE	JAN 2010	JUNE 2010	JAN 2011	JUNE 2011
<b>MUSIC</b>			<b>1271, 2271</b>			
Unit 1	MUSC1	W	-	✓	-	✓
Unit 2A	MUS2A	E	-	✓	-	✓
Unit 2B	MUS2B	E	-	✓	-	✓
Unit 2C	MUS2C	E	-	✓	-	✓
Unit 3	MUSC3	C	-	✓	-	✓
Unit 4	MUSC4	W	-	✓	-	✓
Unit 5A	MUS5A	E	-	✓	-	✓
Unit 5B	MUS5B	E	-	✓	-	✓
Unit 5C	MUS5C	E	-	✓	-	✓
Unit 6	MUSC6	E	-	✓	-	✓
<b>PANJABI</b>			<b>1681, 2681</b>			
Unit 1	PANJ1	W	-	✓	-	✓
Unit 2	PANJ2	W	-	✓	-	✓
<b>PHILOSOPHY</b>			<b>1171, 2171</b>			
Unit 1	PHIL1	W	✓	✓	✓	✓
Unit 2	PHIL2	W	✓	✓	✓	✓
Unit 3	PHIL3	W	-	✓	-	✓
Unit 4	PHIL4	W	-	✓	-	✓
<b>PHYSICAL EDUCATION</b>			<b>1581, 2581</b>			
Unit 1	PHED1	W	✓	✓	✓	✓
Unit 2	PHED2	C	-	✓	-	✓
Unit 3	PHED3	W	-	✓	-	✓
Unit 4	PHED4	C	-	✓	-	✓
<b>PHYSICS A</b>			<b>1451, 2451</b>			
Unit 1	PHYA1	W	✓	✓	✓	✓
Unit 2	PHYA2	W	✓	✓	✓	✓
Unit 3	PHA3T	C	-	✓	-	✓
Unit 3	PHA3X	E	-	✓	-	✓
Unit 4	PHYA4	W	✓	✓	✓	✓
Unit 5	PHA5A	W	-	✓	-	✓
Unit 5	PHA5B	W	-	✓	-	✓
Unit 5	PHA5C	W	-	✓	-	✓
Unit 5	PHA5D	W	-	✓	-	✓
Unit 6	PHA6T	C	-	✓	-	✓
Unit 6	PHA6X	E	-	✓	-	✓
<b>PHYSICS B</b>			<b>1456, 2456</b>			
Unit 1	PHYB1	W	✓	✓	✓	✓
Unit 2	PHYB2	W	✓	✓	✓	✓
Unit 3	PHB3T	C	-	✓	-	✓
Unit 3	PHB3X	E	-	✓	-	✓
Unit 4	PHYB4	W	✓	✓	✓	✓
Unit 5	PHYB5	W	✓	✓	✓	✓
Unit 6	PHB6T	C	-	✓	-	✓
Unit 6	PHB6X	E	-	✓	-	✓
<b>POLISH</b>			<b>1686, 2686</b>			
Unit 1	PLSH1	W	-	✓	-	✓
Unit 2	PLSH2	W	-	✓	-	✓
<b>PSYCHOLOGY A</b>			<b>1181, 2181</b>			
Unit 1	PSYA1	W	✓	✓	✓	✓
Unit 2	PSYA2	W	✓	✓	✓	✓
Unit 3	PSYA3	W	✓	✓	✓	✓
Unit 4	PSYA4	W	✓	✓	✓	✓

UNIT	UNIT ENTRY CODE	UNIT TYPE	JAN 2010	JUNE 2010	JAN 2011	JUNE 2011
<b>PSYCHOLOGY B</b>			<b>1186, 2186</b>			
Unit 1	PSYB1	W	✓	✓	✓	✓
Unit 2	PSYB2	W	✓	✓	✓	✓
Unit 3	PSYB3	W	✓	✓	✓	✓
Unit 4	PSYB4	W	-	✓	-	✓
<b>RELIGIOUS STUDIES</b>			<b>1061, 2061</b>			
AS Unit A	RSS01	W	✓	✓	✓	✓
AS Unit B	RSS02	W	✓	✓	✓	✓
AS Unit C	RSS03	W	✓	✓	✓	✓
AS Unit D	RSS04	W	✓	✓	✓	✓
AS Unit E	RSS05	W	✓	✓	✓	✓
AS Unit F	RSS06	W	✓	✓	✓	✓
AS Unit G	RSS07	W	✓	✓	✓	✓
AS Unit H	RSS08	W	✓	✓	✓	✓
AS Unit J	RSS09	W	✓	✓	✓	✓
AS Unit K	RSS10	W	✓	✓	✓	✓
AS Unit L	RSS11	W	✓	✓	✓	✓
Unit 3A	RST3A	W	-	✓	-	✓
Unit 3B	RST3B	W	-	✓	-	✓
Unit 3C	RST3C	W	-	✓	-	✓
Unit 3D	RST3D	W	-	✓	-	✓
Unit 3E	RST3E	W	-	✓	-	✓
Unit 3F	RST3F	W	-	✓	-	✓
Unit 3G	RST3G	W	-	✓	-	✓
Unit 3H	RST3H	W	-	✓	-	✓
Unit 4A	RST4A	W	-	✓	-	✓
Unit 4B	RST4B	W	-	✓	-	✓
Unit 4C	RST4C	W	-	✓	-	✓
<b>APPLIED SCIENCE</b>						
AS Single (3 units)			<b>8771</b>			
AS Double (6 units)			<b>8773</b>			
A Single (6 units)			<b>8776</b>			
AS Additional (9 units)			<b>8777</b>			
A Double (12 units)			<b>8779</b>			
Unit 1	SC01	P	-	✓	-	✓
Unit 2	SC02	W	✓	✓	✓	✓
Unit 3	SC03	P	-	✓	-	✓
Unit 4	SC04	P	-	✓	-	✓
Unit 5	SC05	W	✓	✓	✓	✓
Unit 6	SC06	P	-	✓	-	✓
Unit 7	SC07	P	-	✓	-	✓
Unit 8	SC08	W	✓	✓	✓	✓
Unit 9	SC09	P	-	✓	-	✓
Unit 10	SC10	P	-	✓	-	✓
Unit 11	SC11	W	✓	✓	✓	✓
Unit 12	SC12	P	-	✓	-	✓
Unit 13	SC13	P	-	✓	-	✓
Unit 14	SC14	W	✓	✓	✓	✓
Unit 15	SC15	P	-	✓	-	✓
Unit 16	SC16	P	-	✓	-	✓

UNIT	UNIT ENTRY CODE	UNIT TYPE	JAN 2010	JUNE 2010	JAN 2011	JUNE 2011
<b>SCIENCE IN SOCIETY</b>			<b>1401, 2401</b>			
Unit 1	SCIS1	W	-	✓	-	✓
Unit 2	SCIS2	C	-	✓	-	✓
Unit 3	SCIS3	W	-	✓	-	✓
Unit 4	SCIS4	W	-	✓	-	✓
<b>SOCIOLOGY</b>			<b>1191, 2191</b>			
Unit 1	SCLY1	W	✓	✓	✓	✓
Unit 2	SCLY2	W	✓	✓	✓	✓
Unit 3	SCLY3	W	✓	✓	✓	✓
Unit 4	SCLY4	W	✓	✓	✓	✓
<b>SPANISH</b>			<b>1696, 2696</b>			
Unit 1	SPAN1	W	✓	✓	✓	✓
Unit 2	SPA2T	CO	✓	✓	✓	✓
Unit 2	SPA2V	VO	-	✓	-	✓
Unit 3	SPAN3	W	-	✓	-	✓
Unit 4	SPA4T	CO	-	✓	-	✓
Unit 4	SPA4V	VO	-	✓	-	✓
<b>STATISTICS</b>			<b>AS 5381</b>		<b>A 6381</b>	
Unit 1A	SS1A	W&C	✓	✓	✓	✓
Unit 1B	SS1B	W	✓	✓	✓	✓
Unit 2	SS02	W	✓	✓	✓	✓
Unit 3	SS03	W	✓	✓	✓	✓
Unit 4	SS04	W	✓	✓	✓	✓
Unit 5	SS05	W	-	✓	-	✓
Unit 6	SS06	W	-	✓	-	✓
<b>TRAVEL AND TOURISM</b>						
<b>AS Single (3 units)</b>			<b>8651</b>			
<b>AS Double (6 units)</b>			<b>8653</b>			
<b>A Single (6 units)</b>			<b>8656</b>			
<b>AS Additional (9 units)</b>			<b>8657</b>			
<b>A Double (12 units)</b>			<b>8659</b>			
Unit 1	TT01	W	✓	✓	✓	✓
Unit 2	TT02	P	-	✓	-	✓
Unit 3	TT03	P	-	✓	-	✓
Unit 4	TT04	P	-	✓	-	✓
Unit 5	TT05	W	✓	✓	✓	✓
Unit 6	TT06	P	-	✓	-	✓
Unit 7	TT07	P	-	✓	-	✓
Unit 8	TT08	P	-	✓	-	✓
Unit 9	TT09	W	✓	✓	✓	✓
Unit 10	TT10	P	-	✓	-	✓
Unit 11	TT11	W	✓	✓	✓	✓
Unit 12	TT12	P	-	✓	-	✓
Unit 13	TT13	P	-	✓	-	✓
Unit 14	TT14	P	-	✓	-	✓

UNIT	UNIT ENTRY CODE	UNIT TYPE	JAN 2010	JUNE 2010
<b>USE OF MATHEMATICS</b>			<b>AS 5351</b>	
FSMQ Unit	6991	W&P	-	✓
FSMQ Unit	6990	W&P	-	✓
FSMQ Unit	6992	W&P	-	✓
FSMQ Unit	6994	W&P	-	✓
Unit 4	UOM4	W	-	✓

## EXTENDED PROJECT QUALIFICATION (LEVEL 3) (AQA-City & Guilds)

UNIT	UNIT ENTRY CODE	UNIT TYPE	NOV 2009	JUNE 2010
<b>EXTENDED PROJECT QUALIFICATION (LEVEL 3)</b>				
Unit 1	9990	C	✓	✓

### Unit type

- C Coursework
- CO Oral (Centre-conducted)
- CT Controlled Test
- CS Case Study
- E Externally-Assessed Assignment
- ES Externally-Set Assignment: Centre assessed
- OT Objective Test
- P Portfolio
- Pr Practical
- Proj Project
- St Study
- S St Synoptic Study
- VO Oral (Visiting Examiner)
- W Written Paper

## FREE-STANDING MATHEMATICS QUALIFICATIONS

UNIT	LEVEL	ENTRY CODE	TYPE	JANUARY 2010	JUNE 2010
Managing Money	Foundation	6981	W&P	✓	✓
Working in 2 and 3 Dimensions	Foundation	6982	W&P	-	✓
Making Sense of Data	Foundation	6983	W&P	✓	✓
Calculating Finances	Intermediate	6984	W&P	✓	✓
Handling and Interpreting Data	Intermediate	6986	W&P	✓	✓
Using Algebra, Functions and Graphs	Intermediate	6988	W&P	-	✓
Using and Applying Statistics	Advanced	6990	W&P	-	✓
Working with Algebraic and Graphical Techniques	Advanced	6991	W&P	-	✓
Modelling with Calculus	Advanced	6992	W&P	-	✓
Using and Applying Decision Mathematics	Advanced	6994	W&P	-	✓

## KEY SKILLS

	LEVEL TYPE	ENTRY CODE	OCT 2009	NOV 2009	JAN 2010	MARCH 2010	MAY 2010	JUNE 2010
<b>APPLICATION OF NUMBER</b>			<b>Unit Certificate 9930</b>					
Level 1	Objective Test	KNT1	✓	✓	✓	✓	✓	✓
Level 2	Objective Test	KNT2	✓	✓	✓	✓	✓	✓
Level 3	Test	KNT3	-	-	✓	✓	-	✓
Level 4	Test	KNT4	-	-	-	-	-	✓
Levels 1-4	Portfolio	YSNP	-	-	✓	✓	-	✓
<b>COMMUNICATION</b>			<b>Unit Certificate 9910</b>					
Level 1	Objective Test	KCT1	✓	✓	✓	✓	✓	✓
Level 2	Objective Test	KCT2	✓	✓	✓	✓	✓	✓
Level 3	Test	KCT3	-	-	✓	✓	-	✓
Level 4	Test	KCT4	-	-	-	-	-	✓
Levels 1-4	Portfolio	YSCP	-	-	✓	✓	-	✓
<b>INFORMATION AND COMMUNICATION TECHNOLOGY</b>			<b>Unit Certificate 9950</b>					
Level 1	Objective Test	KIT1	✓	✓	✓	✓	✓	✓
Level 2	Objective Test	KIT2	✓	✓	✓	✓	✓	✓
Level 3	Test	KIT3	-	-	✓	✓	-	✓
Level 4	Test	KIT4	-	-	-	-	-	✓
Levels 1-4	Portfolio	YSIP	-	-	✓	✓	-	✓

## KEY SKILLS QUALIFICATION SINGLE ASSESSMENT COMPONENT (AVAILABLE TO WELSH CENTRES ONLY)

	ENTRY CODE	OCT 2009	NOV 2009	JAN 2010	MARCH 2010	MAY 2010	JUNE 2010
<b>APPLICATION OF NUMBER</b>							
Portfolio (All Levels)	WSNP	-	-	✓	✓	-	✓
<b>COMMUNICATION</b>							
Portfolio (All Levels)	WSCP	-	-	✓	✓	-	✓
<b>INFORMATION AND COMMUNICATION TECHNOLOGY</b>							
Portfolio (All Levels)	WSIP	-	-	✓	✓	-	✓

## WIDER KEY SKILLS

	LEVEL TYPE	ENTRY CODE	OCT 2009	NOV 2009	JAN 2010	MARCH 2010	MAY 2010	JUNE 2010
<b>WORKING WITH OTHERS</b>								
Levels 1-4	Portfolio	YSWO	-	-	✓	✓	-	✓
<b>IMPROVING OWN LEARNING AND PERFORMANCE</b>								
Levels 1-4	Portfolio	YSLP	-	-	✓	✓	-	✓
<b>PROBLEM SOLVING</b>								
Levels 1-4	P	YSPS	-	-	✓	✓	-	✓

## BASIC SKILLS TESTS

	LEVEL TYPE	ENTRY CODE	OCT 2009	NOV 2009	JAN 2010	MARCH 2010	MAY 2010	JUNE 2010
Literacy Level 1	Objective Test	BLT1	✓	✓	✓	✓	✓	✓
Literacy Level 2	Objective Test	BLT2	✓	✓	✓	✓	✓	✓
Numeracy Level 1	Objective Test	BNT1	✓	✓	✓	✓	✓	✓
Numeracy Level 2	Objective Test	BNT2	✓	✓	✓	✓	✓	✓

## Appendix B: Exemptions from Key Skills – Proxy Qualifications

Please refer to Appendix C for Key Skills Proxy Entry Codes  
This information is taken from the QCDA Website [www.qcda.gov.uk](http://www.qcda.gov.uk)

### Communication Key Skill - Proxy Exemptions

The qualification below	at Grade	exempts a candidate from the Communication:					
		L3 Test?	L3 Portfolio?	L2 Test?	L2 Portfolio?	L1 Test?	L1 Portfolio?
GCE A Level English Language	A-E	Yes	No	Yes	No	Yes	No
GCE A Level English Literature	A-E	Yes	No	Yes	No	Yes	No
GCE A Level English Language and Literature	A-E	Yes	No	Yes	No	Yes	No
GCE AS Level English Language	A-E	Yes	No	Yes	No	Yes	No
GCE AS Level English Literature	A-E	Yes	No	Yes	No	Yes	No
GCE AS Level English Language and Literature	A-E	Yes	No	Yes	No	Yes	No
GCSE English	A*-C	No	No	Yes	No	Yes	No
GCSE English	D-G	No	No	No	No	Yes	No
GCSE English Literature	A*-C	No	No	Yes	No	Yes	No
GCSE English Literature	D-G	No	No	No	No	Yes	No
AQA GCSE General Studies	A*-C	No	No	Yes	No	Yes	No
AQA GCSE General Studies	D-G	No	No	No	No	Yes	No
Certificate in Adult Literacy level 2**	Pass	No	No	Yes	No	Yes	No
Certificate in Adult Literacy level 1**	Pass	No	No	No	No	Yes	No
GCE A level Welsh	A-E	Yes	No	Yes	No	Yes	No
GCE A level Welsh Second Language	A-E	No	No	Yes	No	Yes	No
GCE AS level Welsh	A-E	Yes	No	Yes	No	Yes	No
GCE AS level Welsh Second Language	A-E	No	No	Yes	No	Yes	No
Advanced Subsidiary VCE in Welsh Second Language	A-E	No	No	Yes	No	Yes	No
GCSE Welsh	A*-C	No	No	Yes	No	Yes	No
GCSE Irish (Gaeilge)	A*-C	No	No	Yes	No	Yes	No
GCSE Welsh	D-G	No	No	No	No	Yes	No
GCSE Irish (Gaeilge)	D-G	No	No	No	No	Yes	No
GCSE Welsh Literature	A*-C	No	No	Yes	No	Yes	No
GCSE Welsh Literature	D-G	No	No	No	No	Yes	No
GCSE Welsh Second Language	A*-C	No	No	No	No	Yes	No
<b>GCSE Welsh Second Language</b>	<b>D-G</b>	<b>No</b>	<b>No</b>	<b>No</b>	<b>No</b>	<b>No</b>	<b>No</b>
Welsh Second Language GNVQ units (Intermediate)	Pass-Dist	No	No	No	No	Yes	No
<b>Welsh Second Language GNVQ units (Foundation)</b>	<b>Pass-Dist</b>	<b>No</b>	<b>No</b>	<b>No</b>	<b>No</b>	<b>No</b>	<b>No</b>
<b>Foundation Award in Welsh Second Language</b>	<b>Pass-Dist</b>	<b>No</b>	<b>No</b>	<b>No</b>	<b>No</b>	<b>No</b>	<b>No</b>
Intermediate Award in Welsh Second Language	Pass-Dist	No	No	No	No	Yes	No

Those qualifications in **bold** do not act as proxies for the key skills tests, but are within suites of qualifications where different levels or grades do act as proxies.

\*\* Although this qualification is included on the proxy list, the test that is used for this qualification is the same as the key skills test. Therefore, this is not a standard proxy. It is included on the proxy list only so that it is clear that candidates that have this qualification do not have to also pass a separate key skills test.

## Application of Number Key Skill - Proxy Exemptions

The qualification below	at						
	Grade	exempts a candidate from the Application of number:					
		L3 Test?	L3 Portfolio?	L2 Test?	L2 Portfolio?	L1 Test?	L1 Portfolio?
GCE AS Use of Mathematics	A-E	Yes	Yes	Yes	Yes	Yes	Yes
GCE A Level Mathematics	A-E	Yes	No	Yes	No	Yes	No
GCE A Level Pure Mathematics	A-E	Yes	No	Yes	No	Yes	No
GCE A Level Further Mathematics	A-E	Yes	No	Yes	No	Yes	No
GCE A Level Statistics	A-E	Yes	No	Yes	No	Yes	No
GCE AS Level Mathematics	A-E	Yes	No	Yes	No	Yes	No
GCE AS Level Pure Mathematics	A-E	Yes	No	Yes	No	Yes	No
GCE AS Level Further Mathematics	A-E	Yes	No	Yes	No	Yes	No
GCE AS Level Statistics	A-E	Yes	No	Yes	No	Yes	No
GCE AS Mechanics	A-E	Yes	No	Yes	No	Yes	No
GCE AS Discrete Mathematics	A-E	Yes	No	Yes	No	Yes	No
GCE AS Applied Mathematics	A-E	Yes	No	Yes	No	Yes	No
GCSE Mathematics	A*-C	No	No	Yes	No	Yes	No
GCSE Mathematics	D-G	No	No	No	No	Yes	No
GCSE Use of Mathematics	A*-C	No	No	Yes	No	Yes	No
GCSE Use of Mathematics	D-G	No	No	No	No	Yes	No
Certificate in Adult Numeracy level 2**	Pass	No	No	Yes	No	Yes	No
Certificate in Adult Numeracy level 1**	Pass	No	No	No	No	Yes	No

*\*\* Although this qualification is included on the proxy list, the test that is used for this qualification is the same as the key skills test. Therefore, this is not a standard proxy. It is included on the proxy list only so that it is clear that candidates that have this qualification do not have to also pass a separate key skills test.*

## Information and Communication Technology Key Skill - Proxy Exemptions

The qualification below	at	exempts a candidate from the ICT:					
		Grade	L3 Test?	L3 Portfolio?	L2 Test?	L2 Portfolio?	L1 Test?
Edexcel Level 1 Award in Digital Applications for IT Users	Pass	No	No	No	No	Yes	Yes
Edexcel Level 2 Award in Digital Applications for IT Users	Pass	No	No	Yes	Yes	Yes	Yes
Edexcel Level 1 Certificate in Digital Applications for IT Users	Pass	No	No	No	No	Yes	Yes
Edexcel Level 2 Certificate in Digital Applications for IT Users	Pass	No	No	Yes	Yes	Yes	Yes
Edexcel Level 1 Diploma in Digital Applications for IT Users	Pass	No	No	No	No	Yes	Yes
Edexcel Level 2 Diploma in Digital Applications for IT Users	Pass	No	No	Yes	Yes	Yes	Yes
OCR Level 2 Certificate for IT Users (CLAiT Plus)	Pass	No	No	Yes	No	Yes	No
OCR Level 3 Certificate for IT Users (Advanced CLAiT)	Pass	Yes	No	Yes	No	Yes	No
BCS Level 2 Certificate for IT Users (ECDL)	Pass	No	No	Yes	No	Yes	No
GCE A Level Computing	A-E	Yes	Yes	Yes	Yes	Yes	Yes
GCE A Level ICT	A-E	Yes	Yes	Yes	Yes	Yes	Yes
GCE AS Level Computing	A-E	Yes	No	Yes	No	Yes	No
GCE AS Level ICT	A-E	Yes	No	Yes	No	Yes	No
GCE AS Level in Applied ICT	A-E	Yes	Yes	Yes	Yes	Yes	Yes
GCE AS Level in Applied ICT (Double Award)	AA-EE	Yes	Yes	Yes	Yes	Yes	Yes
GCE A Level in Applied ICT	A-E	Yes	Yes	Yes	Yes	Yes	Yes
GCE A Level in Applied ICT (Double Award)	AA-EE	Yes	Yes	Yes	Yes	Yes	Yes
GCSE Computer Studies	A*-C	No	No	Yes	Yes	Yes	Yes
GCSE Computer Studies	D-G	No	No	No	No	Yes	Yes
GCSE ICT	A*-C	No	No	Yes	Yes	Yes	Yes
GCSE ICT	D-G	No	No	No	No	Yes	Yes
GCSE in Applied ICT (Double Award)	A*A*-CC	No	No	Yes	Yes	Yes	Yes
GCSE in Applied ICT (Double Award)	DD-GG	No	No	No	No	Yes	Yes
GCSE Information Systems	A*-C	No	No	Yes	Yes	Yes	Yes
GCSE Information Systems	D-G	No	No	No	No	Yes	Yes
Vocational A Level ICT Double Award	A-E	Yes	Yes	Yes	Yes	Yes	Yes
Vocational A Level ICT	A-E	Yes	Yes	Yes	Yes	Yes	Yes
Vocational Advanced Subsidiary ICT	A-E	Yes	Yes	Yes	Yes	Yes	Yes
Advanced GNVQ (Part Award, Single Award or Double Award) ICT	Pass/Merit /Dist	Yes	Yes	Yes	Yes	Yes	Yes
Intermediate GNVQ (full award or part one award) ICT	Pass/Merit / Dist	No	No	Yes	Yes	Yes	Yes
Foundation GNVQ (full award or part one award) ICT	Pass/Merit /Dist	No	No	No	No	Yes	Yes

Please note that, for qualifications pre-2003, the terms ICT and IT are interchangeable.

## Special note for GCSE Short Course ICT and GCSE Short Course Information Technology

<i>The qualification below</i>	<i>at</i>		<i>exempts a candidate from the ICT:</i>				
	<b>Grade</b>	<b>L3 Test?</b>	<b>L3 Portfolio?</b>	<b>L2 Test?</b>	<b>L2 Portfolio?</b>	<b>L1 Test?</b>	<b>L1 Portfolio?</b>
GCSE Short course ICT or IT	A*-C	No	No	Yes	Yes	Yes	Yes
GCSE Short course ICT or IT	D-G	No	No	No	No	Yes	Yes

<i>The qualification below</i>	<i>at</i>		<i>exempts a candidate from the ICT:</i>				
	<b>Grade</b>	<b>L3 Test?</b>	<b>L3 Portfolio?</b>	<b>L2 Test?</b>	<b>† one of the 2 specified purposes in the L2 Portfolio?</b>	<b>L1 Test?</b>	<b>† one of the 2 specified purposes in the L1 Portfolio?</b>
GCSE Short Course Information Systems	A*-C	No	No	Yes	Yes	Yes	Yes
GCSE Short Course Information Systems	D-G	No	No	No	No	Yes	Yes

† Claims for exemption from part of the portfolio assessment are **not** made through entry codes. The details of the proxy qualification should be noted in the candidate's log book and endorsed by the teacher.

## SQA Qualifications (National Courses) that act as proxies for Key Skills

Following discussion between the Regulatory Authorities for England (QCDA), Wales (ACCAC) and Northern Ireland (CCEA) and the Scottish Qualifications Authority (SQA) it has been agreed that certain SQA qualifications will act as proxies for the key skills tests. These arrangements mirror those already agreed for GCSEs and A/AS levels in England, Wales and Northern Ireland. Please check the tables below for details.

### Communication Key Skill - Proxy Exemptions

<i>The qualification below</i>	<i>at</i>	<i>exempts a candidate from the Communication:</i>					
		<b>Grade</b>	<b>L3 Test?</b>	<b>L3 Portfolio?</b>	<b>L2 Test?</b>	<b>L2 Portfolio?</b>	<b>L1 Test?</b>
Standard Grade English	General	No	No	No	No	Yes	No
English and Communication	Intermediate 1	No	No	No	No	Yes	No
Standard Grade English	Credit	No	No	Yes	No	Yes	No
English	Intermediate 2	No	No	Yes	No	Yes	No
English and Communication	Higher	Yes	No	Yes	No	Yes	No
English (Previously English and Communication)	Advanced Higher	Yes	No	Yes	No	Yes	No

### Application of Number Key Skill - Proxy Exemptions

<i>The qualification below</i>	<i>at</i>	<i>exempts a candidate from the Application of number:</i>					
		<b>Grade</b>	<b>L3 Test?</b>	<b>L3 Portfolio?</b>	<b>L2 Test?</b>	<b>L2 Portfolio?</b>	<b>L1 Test?</b>
Standard Grade Mathematics	General	No	No	No	No	Yes	No
Mathematics	Intermediate 1	No	No	No	No	Yes	No
Standard Grade Mathematics	Credit	No	No	Yes	No	Yes	No
Mathematics	Intermediate 2	No	No	Yes	No	Yes	No
Mathematics	Higher	Yes	No	Yes	No	Yes	No
Mathematics	Advanced Higher	Yes	No	Yes	No	Yes	No
Applied Mathematics	Advanced Higher	Yes	No	Yes	No	Yes	No

### Information and Communication Technology Key Skill - Proxy Exemptions

<i>The qualification below</i>	<i>at</i>	<i>exempts a candidate from the ICT:</i>					
		<b>Grade</b>	<b>L3 Test?</b>	<b>L3 Portfolio?</b>	<b>L2 Test?</b>	<b>L2 Portfolio?</b>	<b>L1 Test?</b>
Standard Grade Computing Studies	General	No	No	No	No	Yes	No
Computing Studies	Intermediate 1	No	No	No	No	Yes	No
Standard Grade Computing Studies	Credit	No	No	Yes	No	Yes	No
Computing	Intermediate 2	No	No	Yes	No	Yes	No
Information Systems	Intermediate 2	No	No	Yes	No	Yes	No
Computing	Higher	Yes	No	Yes	No	Yes	No
Computing	Advanced Higher	Yes	No	Yes	No	Yes	No
Information Systems	Higher	Yes	No	Yes	No	Yes	No
Information Systems	Advanced Higher	Yes	No	Yes	No	Yes	No

## Proxy arrangements for the Irish Leaving Certificate

<i>The qualification below</i>	<i>at</i> <b>Grade</b>	<i>exempts a candidate from Communication</i>					
		<b>L3 Test?</b>	<b>L3 Portfolio?</b>	<b>L2 Test?</b>	<b>L2 Portfolio?</b>	<b>L1 Test?</b>	<b>L1 Portfolio?</b>
Leaving Certificate English (Higher level)	A1-C2	Yes	No	Yes	No	Yes	No
Leaving Certificate English (Higher level)	C1-D3	No	No	Yes	No	Yes	No
Leaving Certificate English (Ordinary level)	A1-B3	No	No	Yes	No	Yes	No
Leaving Certificate English (Ordinary level)	C1-D3	No	No	No	No	Yes	No

<i>The qualification below</i>	<i>at</i> <b>Grade</b>	<i>exempts a candidate from Application of Number</i>					
		<b>L3 Test?</b>	<b>L3 Portfolio?</b>	<b>L2 Test?</b>	<b>L2 Portfolio?</b>	<b>L1 Test?</b>	<b>L1 Portfolio?</b>
Leaving Certificate Maths (Higher level)	A1-C2	Yes	No	Yes	No	Yes	No
Leaving Certificate Maths (Higher level)	C1-D3	No	No	Yes	No	Yes	No
Leaving Certificate Maths (Ordinary level)	A1-B3	No	No	Yes	No	Yes	No
Leaving Certificate Maths (Ordinary level)	C1-D3	No	No	No	No	Yes	No

## Appendix C: Key Skills Proxy Entry Codes

Key Skills Proxy	Entry Codes	
Communication Test Proxy	Level 1	KCX1
	Level 2	KCX2
	Level 3	KCX3
	Concurrent AQA GCE AS/A entry	KCXX
Application of Number Test Proxy	Level 1	KNX1
	Level 2	KNX2
	Level 3	KNX3
	Concurrent AQA GCE AS/A entry	KNXX
Application of Number Unit Proxy	Level 3	8933
	Concurrent AQA GCE AS entry	8939
Information and Communication Technology Test Proxy	Level 1	KIX1
	Level 2	KIX2
	Level 3	KIX3
	Concurrent AQA GCE AS entry	KIXX
Information and Communication Technology Unit Proxy	Level 1	8951
	Level 2	8952
	Level 3	8953
	Concurrent AQA GCE A entry	8959

AQA City & Guilds CCEA Edexcel OCR SQA WJEC

Produced on behalf of: AQA, CCEA, Edexcel, OCR and WJEC.

### Notice to centres

#### Withdrawal of Curriculum 2000 GCE specifications

##### Assessment arrangements during the transition from current (legacy) specifications to new specifications

The JCQ awarding bodies wish to remind GCE centres of the assessment arrangements during the transition from current (legacy) specifications to new specifications. Individual awarding bodies will notify centres of the particular arrangements for their own specifications. The following table lists the proposed **minimum** assessment opportunities for the period covering the withdrawal of the current (legacy) GCE specifications and the phasing in of the newly accredited specifications.

Examination series	Current (legacy) specifications	New specifications
January 2009	Only those AS and A2 units that are normally offered in the winter series will be available. <i>Certification of AS and A level possible.</i>	Those AS units that are shown in the specification as being available in this series are offered. <i>No certification of new AS possible.</i>
June 2009	All AS and A2 units that are normally offered in the summer series will be available. <i>Certification of AS and A level possible.</i>	All AS units offered. <i>Certification of new AS possible.</i>
January 2010*	Externally assessed A2 units available if notification of intention to enter received by AB. This will be the final re-sit opportunity for these A2 units. <i>Certification of AS and A level possible.</i>	Those AS and A2 units that are shown in the specification as being available in this series are offered. <i>Certification of new AS possible.</i>
June 2010 <sup>§</sup>	No units offered. <i>No certification possible.</i>	All AS and A2 units available. <i>Certification of AS and A level possible.</i>

\* An awarding body may, in addition, choose also to offer externally assessed AS units in this series.

§ An awarding body may choose to offer some externally assessed A2 units and also AS and A level certification in this series.

In light of this schedule for withdrawal given overleaf, students embarking upon a one year programme leading to the award of an AS qualification in June 2009 are reminded of the fact that the June 2009 examination series is intended to be the last one in which legacy AS units will normally be examined. Centres may therefore wish to prepare these students for examinations in the AS units of the new specifications, which will permit an entry for re-sits in a subsequent examination series, should that need arise.

**The JCQ awarding bodies will not routinely transfer credit from current (legacy) AS specifications to new A level specifications. It will not be possible for students to combine legacy and new units to make up a whole A level qualification. Transfer of credit is only possible between specifications that have been written to the same criteria.**